



**DASH 8**  
**AIRCRAFT RECOVERY**  
**MANUAL**

**BOEING CANADA**  
**DE HAVILLAND DIVISION**  
**DOWNSVIEW, ONTARIO, CANADA M3K 1Y5**

**OCT 10/90**

**PSM 1-8-9**

**OCT 10/90**

## **DASH 8 AIRCRAFT RECOVERY**

### **IMPORTANT MESSAGE TO USERS OF THIS DOCUMENT**

The generalized recovery techniques and methods described in this document are intended only for general planning purposes and to illustrate the use of special recovery equipment and procedures for Dash-8 Aircraft.

The data presented in this document was calculated for hypothetical aircraft conditions or for specific conditions which have occurred in the past. Because every situation requiring recovery is unique, the recovery method appropriate in a particular situation will depend upon the circumstances and the available recovery equipment.

### **DISCLAIMER**

**BOEING, DE HAVILLAND DIVISION MAKES NO WARRANTY OR GUARANTEE WHATSOEVER IN CONNECTION WITH THE INFORMATION FURNISHED IN THIS DOCUMENT OR THE USE OR IMPLEMENTATION OF SUCH INFORMATION, AND THE USER OF THIS DOCUMENT HEREBY WAIVES, RELEASES AND RENOUNCES ALL WARRANTIES, OBLIGATIONS AND LIABILITIES OF BOEING, DE HAVILLAND DIVISION, AND RIGHT, CLAIMS AND REMEDIES OF THE USER AGAINST BOEING, DE HAVILLAND DIVISION, EXPRESS OR IMPLIED, ARISING BY LAW OR OTHERWISE, WITH RESPECT TO ANY DEFECT IN ANY INFORMATION FURNISHED HEREIN, INCLUDING BUT NOT LIMITED TO (A) ANY IMPLIED WARRANTY OF MERCHANTABILITY OR FITNESS, (B) ANY IMPLIED WARRANTY ARISING FROM COURSE OF PERFORMANCE, COURSE OF DEALING OR USAGE OF TRADE, (C) ANY OBLIGATION, LIABILITY, RIGHT, CLAIM OR REMEDY IN TORT, WHETHER OR NOT ARISING FROM BOEING, DE HAVILLAND DIVISION, NEGLIGENCE ACTUAL OR IMPUTED, AND (D) ANY OBLIGATION, LIABILITY, RIGHT, CLAIM OR REMEDY FOR LOSS OF USE, REVENUE OR PROFIT, OR FOR ANY OTHER DIRECT, INCIDENTAL OR CONSEQUENTIAL DAMAGES.**

**Boeing Canada**  
de Havilland Division

**DASH 8 AIRCRAFT RECOVERY**

**THIS PAGE INTENTIONALLY LEFT BLANK**

**OCT 10/90**



**Boeing Canada**  
de Havilland Division  
**DASH 8 AIRCRAFT RECOVERY**

**LIST OF CHAPTERS**

The following is a List of Chapters contained in this manual.

<u>Chapter No.</u>	<u>Chapter Title</u>	<u>Latest Effective Revision Date</u>
1	INTRODUCTION	
2	SURVEY AND PREPARATION	
3	STABILIZE AIRCRAFT	
4	MOVING AIRCRAFT	
5	TOOLING AND EQUIPMENT	
6	PREVIOUS AIRCRAFT RECOVERY EXPERIENCE	

**CHAPTERS**

PAGE 1

OCT 10/90

**Boeing Canada**  
de Havilland Division  
**DASH 8 AIRCRAFT RECOVERY**

**THIS PAGE INTENTIONALLY LEFT BLANK**

**CHAPTERS**

**PAGE 2**

**OCT 10/90**









**BOMBARDIER**



**AIRCRAFT RECOVER MANUAL**

**EFFECTIVE TEMPORARY REVISIONS**

List of Temporary Revisions effective in your Manual at Revision Initial Issue dated October 10, 1990.

<b>TR NO.</b>	<b>SECTION AND PAGE NO.</b>	<b>ISSUE DATE</b>
1	4-10-00-1	Feb 6/97
2	04-20-00-12	May 26/05

MASTER  
EFFECTIVITY: ALL

Effective Temporary Revisions

PAGE 1





**Boeing Canada**  
de Havilland Division  
**DASH 8 AIRCRAFT RECOVERY**

**INTRODUCTION**

**1. Organization**

This manual has been prepared generally in accordance with ATA Specification No. 100.

**2. Content**

The Aircraft Recovery Manual describes the Dash-8 aircraft recovery operations in terms of equipment and tooling requirements as well as procedures necessary to lift, shore and recover the aircraft from most abnormal conditions to which it may be subjected.

This manual contains information in sufficient detail to effect recovery in the most expeditious manner while maintaining consideration of recovery personnel safety and prevention of additional damage to the aircraft.

**3. Using the Manual**

**A. Chapterization**

Chapters are allocated in accordance with ATA Specification No. 100.

**B. Chapter Breakdown**

Each chapter is divided into sections and, where necessary, each section into subjects. These three elements (Chapter - Section - Subject) are allocated numbers which are located on the lower right hand corner of each page. The following is an example of a three element number:

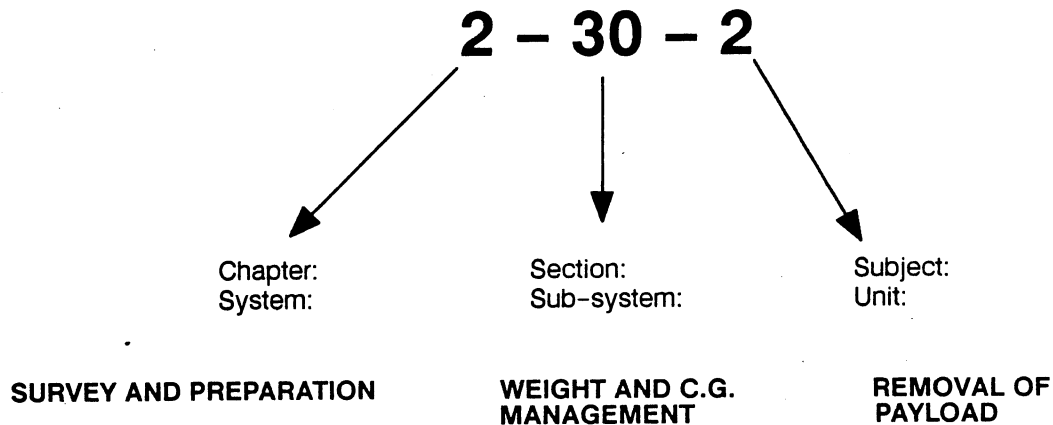

**INTRODUCTION**

## DASH 8 AIRCRAFT RECOVERY

### C. Page Number

Page numbers start with number one for each new Chapter/Section/Subject break down, the pages are numbered consecutively thereafter through the material written on the subject.

### D. List of Effective Pages

In order that users can establish that a Chapter is complete, and whether it contains the latest issue of all pages, a List of Effective Pages is located at the front of each chapter, immediately following the chapter divider card. On each list, the date against each page number should correspond with the date on the relevant page.

## 4. Associated Manuals

Throughout this manual, cross references are made to other publications. A list of associated manuals follows:

	SERIES 100	SERIES 300
Aircraft Operating Data	PSM 1-8-1	PSM 1-83-1
Flight Manual	PSM 1-8-1A	PSM 1-83-1A
Maintenance Manual	PSM 1-8-2	PSM 1-83-2
Ramp Servicing Manual	PSM 1-8-2S	PSM 1-83-2S
Tools and Equipment Manual	PSM 1-8-2T	PSM 1-83-2T
Wiring Diagrams Manual	PSM 1-8-2W	PSM 1-83-2W
Structural Repair Manual	PSM 1-8-3	PSM 1-83-3
Parts Manual	PSM 1-8-4	PSM 1-83-4
*Component Maintenance Manuals	PSM 1-8-6	PSM 1-83-6
Maintenance Program	PSM 1-8-7	PSM 1-83-7
Non-destructive Testing Manual	PSM 1-8-7A	PSM 1-83-7A
Weight and Balance Manual	PSM 1-8-8	PSM 1-83-8
Cargo Loading Manual	PSM 1-8-8A	PSM 1-83-8A
Power Plant Build-up Manual	PSM 1-8-10	PSM 1-83-10
Modifications and Options Manual	PSM 1-8-12	PSM 1-83-12
Vendor Warranties Manual	PSM 1-8-15	PSM 1-83-15
PW120 Engine Maintenance Manual		
14SF-7 Propeller Maintenance Manual		

\* Available for component repair and overhaul.

# INTRODUCTION

## **DASH 8 AIRCRAFT RECOVERY**

### **5. Revisions**

#### **A. Normal Revisions**

Revisions will be made to this manual concurrent with the development of any new data or industry experience which warrants revision action. (Qualified holders will receive copies without request).

#### **B. Temporary Revisions**

Temporary revisions will be issued at the earliest opportunity, to notify the operator of important changes affecting recovery procedures for the aircraft. These revisions will be printed on Yellow Paper for instant identification when inserted in the manual.

### **6. Reference Information**

A. Throughout the text of this document, Metric equivalents are assigned to numerical values which are in English units. Metric equivalents are shown in parentheses located next or below the English unit. Where none are shown, but are desired by the user, charts and equivalents are provided in this chapter.

B. Body coordinates; i.e., body stations, buttock lines and water lines, are maintained in their original form. These, of course, are in inches but are referenced in this document. However, for measurement purposes, dimension lines are extensively provided with the corresponding Metric equivalents.

### **7. English - Metric Conversion**

A. A conversion chart is provided. Represented are the most commonly used units of measure.

# **INTRODUCTION**

**Boeing Canada**  
de Havilland Division  
**DASH 8 AIRCRAFT RECOVERY**

**8. Other Useful Conversion Factors**

Some conversion factors and equivalents which are useful but not covered in English - Metric Conversion on pages 5 and 6 are shown below.

<b>FACTOR</b>	<b>MULTIPLY BY</b>	<b>TO OBTAIN</b>
7.48	CUBIC FEET	GALLONS (U.S)
3.785	GALLONS (U.S.)	LITERS
28.317	CUBIC FOOT/MIN.	LITERS/MIN.
1.15	KNOTS	MILES PER HOURS
3415	KW-HR.	BTU PER HOUR

Weight of Fuel, Jet "A" = 6.74 lbs/U.S. gal.

JP-4 = 6.55 lbs/U.S. gal.

Weight of Water = 8.345 lbs/U.S. gal. @62°F.  
= 62.35 lbs/cu. ft. @ 62°F.

**INTRODUCTION**

PAGE 4

OCT 10/90

**Boeing Canada**  
de Havilland Division

**DASH 8 AIRCRAFT RECOVERY**

**METRIC CONVERSIONS**

NOTE: TO EXTEND OR REDUCE VALUE RANGES (EXCEPT TEMP)  
MULTIPLY OR DIVIDE BY 10

**LIQUID MEASURE:**

Quarts  
Liters  
1 qt = 0.9463 liters  
1 liter = 1.057 qts.

Gallons  
Liters  
1 gal = 3.785 liters  
1 liter = 0.2642 gals

**VELOCITY:**

Miles/Hour  
Kilometers/Hr.  
1 m.p.h. = 1.609 km/hr.  
1 km/hr = 0.6214 m.p.h.

Knots  
Kilometers/Hr.  
1 Kn. = 1.8532 Km/hr.  
1 Kn/hr = 0.5396 Km.

**PRESSURE:**

Pounds/inch<sup>2</sup>  
Kilograms/Centmtr<sup>2</sup>  
1 p.s.i. = 0.0703 kg/cm<sup>2</sup>  
1 kg/cm<sup>2</sup> = 14.22 p.s.i.

Pounds/foot<sup>2</sup>  
Kilograms/meter<sup>2</sup>  
1 p.s.f. = 4.882 kg/m<sup>2</sup>  
1 kg/m<sup>2</sup> = 0.2048 p.s.f.

**RATE:**

Pounds/minute  
Kilogram/minute  
1 lb/min = 0.4536 kg/min  
1 kg/min = 2.204 lb/min

Gallons/minute  
Liters/minute  
1 g.p.m = 3.785 l/min.  
1 l/min = 0.2642 g.p.m.

**TEMP:**

Fahrenheit  
Centigrade  
 $^{\circ}\text{C} = 5/9 (^{\circ}\text{F} - 32^{\circ})$   
 $^{\circ}\text{F} = 9/5^{\circ}\text{C} + 32^{\circ}$

**LINEAR MEASURE:**

Inches  
Centimeters  
1 in = 2.54 cm  
1 cm = 0.3937 in

Feet  
Meters  
1 ft = 0.3048 m  
1 m = 3.281 ft.

Miles  
Kilometers  
1 mi = 1.609 km.  
1 km = 0.6214 mi.

Nautical Miles  
Kilometers  
1 N.mi = 1.8532 km.  
1 km = 0.5396 N.mi.

**AREA:**

Inches<sup>2</sup>  
Centimeters<sup>2</sup>  
1 in<sup>2</sup> = 6.452 cm<sup>2</sup>  
1 cm<sup>2</sup> = 0.155 in<sup>2</sup>

Feet<sup>2</sup>  
Meters<sup>2</sup>  
1 ft<sup>2</sup> = 0.0929 m<sup>2</sup>  
1 m<sup>2</sup> = 10.76 ft<sup>2</sup>

**INTRODUCTION**

## **DASH 8 AIRCRAFT RECOVERY**

### **METRIC CONVERSIONS**

**VOLUME:**

Inches<sup>3</sup>  
Centimeters<sup>3</sup>  
1 in<sup>3</sup> = 16.39 cm<sup>3</sup>  
1 cm<sup>3</sup> = 0.061 in<sup>3</sup>

Feet<sup>3</sup>  
Meters<sup>3</sup>  
1 ft<sup>3</sup> = 0.0283 m<sup>3</sup>  
1 m<sup>3</sup> = 35.31 ft<sup>3</sup>

**WEIGHT:**

Pounds  
Kilograms  
1 lb = 0.4536 kgs.  
1 kg = 2.205 lb.

Tons  
Metric Tons  
1T = 0.907 metric ton  
1 metric ton = 1.102 T

# **INTRODUCTION**

**Boeing Canada**  
de Havilland Division  
**DASH 8 AIRCRAFT RECOVERY**

**LIST OF EFFECTIVE PAGES: CHAPTER 1: GENERAL**

<b>Reference</b>	<b>Page</b>	<b>Date</b>	<b>Reference</b>	<b>Page</b>	<b>Date</b>
Contents	1	Oct 10/90			
	2	Blank			
1-00-00	1	Oct 10/90			
	2	Oct 10/90			
	3	Oct 10/90			
	4	Blank			
1-10-00	1	Oct 10/90			
	2	Oct 10/90			
	3	Oct 10/90			
	4	Blank			
1-20-00	1	Oct 10/90			
	2	Oct 10/90			
	3	Oct 10/90			
	4	Oct 10/90			
	5	Oct 10/90			
	6	Oct 10/90			
	7	Oct 10/90			
	8	Oct 10/90			
1-30-00	1	Oct 10/90			
	2	Oct 10/90			
	3	Oct 10/90			
	4	Oct 10/90			
	5	Oct 10/90			
	6	Oct 10/90			
1-40-00	1	Oct 10/90			
	2	Oct 10/90			
	3	Oct 10/90			
	4	Oct 10/90			
	5	Oct 10/90			
	6	Oct 10/90			
	7	Oct 10/90			
	8	Oct 10/90			
	9	Oct 10/90			
	10	Blank			

The asterisk (\*) indicates pages revised, added or deleted by current revision.

## 1-EFFECTIVE PAGES

**Boeing Canada**  
de Havilland Division  
**DASH 8 AIRCRAFT RECOVERY**

**THIS PAGE INTENTIONALLY LEFT BLANK**

**1-EFFECTIVE PAGES**

**PAGE 2**

**OCT 10/90**



**Boeing Canada**  
de Havilland Division  
**DASH 8 AIRCRAFT RECOVERY**

**CHAPTER 1 - GENERAL**

**TABLE OF CONTENTS**

<b>Subject</b>	<b>Chapter Section Subject</b>	<b>Page</b>
<b>AIRCRAFT GENERAL</b>	<b>1-00-00</b>	
General		1
Fuselage		
Landing Gear		2
Wings		3
Fuel		
<b>AIRCRAFT DIMENSIONS</b>	<b>1-10-00</b>	
Dimensions		1
Areas		3
<b>AIRCRAFT STATIONS</b>	<b>1-20-00</b>	
General		1
Aircraft Coordinate System		
<b>AIRCRAFT SERVICING POINTS</b>	<b>1-30-00</b>	
General		1
<b>DOORS</b>	<b>1-40-00</b>	
General		1

**1-CONTENTS**

**Boeing Canada**  
de Havilland Division  
**DASH 8 AIRCRAFT RECOVERY**

**THIS PAGE INTENTIONALLY LEFT BLANK**

**1-CONTENTS**

PAGE 2

OCT 10/90

**Boeing Canada**  
de Havilland Division  
**DASH 8 AIRCRAFT RECOVERY**

**GENERAL**

Aircraft General

**1. General**

The Dash-8 (DHC-8) aircraft, manufactured by Boeing Canada, De Havilland Division, is a predominately metal high winged monoplane with fully cantilevered wings and horizontal stabilizer surfaces, a semi-monocoque fuselage and a fully retractable tricycle landing gear. Powered by two Pratt and Whitney PW 120-A Turboprop engines driving Hamilton Standard 14SF-7 four bladed, constant speed variable and reversible pitch propellers.

It is designed for short and medium range passenger or cargo transportation, under day and night all-weather conditions. The DASH 8 is air conditioned and pressurized for passenger flights up to 25,000 ft., and is equipped with airframe and propeller deicing. The required flight crew is a pilot, copilot, and one flight attendant to service up to 36 passengers. The aircraft's maximum take-off weight of 34500 lb (15650 Kg) yields a maximum payload, in the standard passenger configuration of 9,410 lb (4268 Kg).

**2. Fuselage**

The fuselage consists of three main sections; nose, center and rear. The basic structure is of conventional all metal construction utilizing high strength aluminum alloy (2024 and 7075) frames, stringers and skin plating throughout. Metal to metal bonding, epoxy adhesion system, is used in the primary structure.

**A. Nose Section**

The nose section extends rearward to the center section fuselage, Sta. X201.150. It contains the flight compartment which is separated from the main cabin by a bulkhead which contains a lockable door. An emergency exit is provided via a removable hatch in the canopy roof which also provides a means of ventilation when on the ground.

The forward pressure bulkhead is located just ahead of the windshield at Sta. X110.0. The area forward of this bulkhead encloses the unpressurized equipment compartment and supports the weather radar unit and the nose cone. The nose landing gear and nosewheel well are located below the equipment compartment.

**B. Center Section**

The center section extends from the nose section (Sta X201.150) to the rear pressure dome at Sta. X653.349. It is largely a constant cross section consisting of a circular upper section of 106 in. outside diameter with a flattened bottom of larger radius. Extensive use is made of metal bonding of stringers and window reinforcements to the skin, to achieve minimum weight, to permit a flush riveted exterior surface and to stop crack propagation.

The wing structure is attached to fittings on the center section with tension bolts. Floor loads are supported by the seat rails and frames. The floor structure will stabilize the frames in the event of a wheels up landing.

**1-00-00**

PAGE 1

OCT 10/90

## **DASH 8 AIRCRAFT RECOVERY**

The passenger airstair door is 30 in. (76.2 cm) wide and 66 in. (167.64 cm) high and is located forward on the left side of the fuselage. Three emergency exits are also provided, two forward of the front spar and one opposite the airstair door.

The baggage compartment at the rear of this section has a capacity of approx. 340 cu. ft. It is accessible through a removable panel in the cabin bulkhead and through an external door approx. 50 in. (127 cm) wide by 60 in. (152.4 cm) high on the left side of the fuselage. The weight capacity of this compartment is 2000 lbs (907.2 Kg).

### **C.. Rear Section**

The rear section consists of the rear fuselage section with the integral vertical stabilizer and dorsal fin. The lower portions of the three stabilizer spars extend downwards to form the main frames of the rear fuselage. The area between the front and center frame serves as an equipment bay for the air cycle machine. Access is provided by an access panel in the bottom of the fuselage aft of the center frame.

### **D. Floor Panels**

The cabin floor panels are removable. Each panel is of sandwich construction consisting of five laminates of epoxy impregnated organic fiber cloth with a phenolic coated fibrous nylon honeycomb core.

The baggage compartment floor panels from the bulkhead to the step are approx. 0.60 in. thick and are constructed of aluminum alloy top and bottom skins with a balsa core.

The floor aft of the step is a composite construction with three laminates on the upper surface and two on the lower surface.

## **3. Landing Gear**

The retractable landing gear consists of two main gear assemblies, one mounted in each nacelle, and a nose gear assembly mounted in a well in the front fuselage. Both main and nose gear assemblies incorporate shock struts and dual wheels, and are fully enclosed by doors when retracted. On both main and nose gear assemblies the doors close after extension of the gear to protect against debris. Disc brakes at each main wheel are operated hydraulically through anti-skid units, and the nose wheel is steered hydraulically.

The main gear assemblies retract rearward and the nose gear assembly retracts forward; normal extension and retraction are hydraulically actuated by the No. 2 main hydraulic system (refer to Maintenance Manual PSM 1-8-2 or PSM 1-83-2).

A fixed tail bumper manufactured from Prothane-Polyurethane compound, is located at Sta. X723 on the underside of the rear cone. The tail bumper is provided to minimize damage to the rear fuselage by absorbing a portion of the impact energy should a tail-down situation occur during take off and landing.

**1-00-00**

**Boeing Canada**  
de Havilland Division  
**DASH 8 AIRCRAFT RECOVERY**

**4. Wings**

The wing is a single, high aspect ratio, cantilevered unit married in the center to the upper mid section of the fuselage. It incorporates integral fuel tanks, nacelle mounting structures, ailerons, flaps and spoilers. The portions of the wing outboard of the engine nacelles are tapered and have a dihedral angle of 2.5°.

**5. Fuel**

Fuel is contained in two integral main tanks and two auxiliary tanks (SOO 8061), each supplying fuel to its own individual engine. Inter-tank transfer is available to permit balancing of the fuel level in the tanks. Fuel from each tank is fed to its engine by an engine feed pumping system contained in a collector bay at the inner end of the tank. The level in the collector bay is maintained by a collector bay pumping system to provide engine feed regardless of aircraft attitude. In each tank, venting is by a vent line from the collector bay to a surge bay at the outer end of the tank and a vent float valve, also into the surge bay.

Pressure refueling and defueling can be accomplished through a single point refuel/defuel adapter located in the right nacelle and is controlled from an adjacent refuel/defuel control panel. As an alternative to pressure refueling, each tank can be filled through an overwing filler point.

Each tank has its own capacitance type fuel quantity indicating system which provides an input to control pressure refueling/defueling levels in addition to its primary function. Fuel low level warnings are also provided for each tank.

Drain valves, located at the low points in each tank, are provided to permit checks for water accumulation and to drain residual fuel from the tanks when required.

**A. Main Fuel Tank**

The main fuel tank in each wing extends from station YW171.992 to YW387.00 (spanwise) and from front to rear spar (chordwise). The inboard end of each tank is walled in to form a compartment termed the collector bay. An over-wing gravity filling point is provided in the wing upper skin. When fueling by pressure, all fuel is pumped into the collector bay. Sumps at the low points in each tank contain a drain valve. Other components in the tanks are shown in Maintenance Manual PSM 1-8-2 or PSM 1-83-2.

**B. Auxiliary Fuel Tank**

The auxiliary fuel tank in each wing extends from station YW42.00 to YW171.20 (spanwise) and from front to rear spar (chordwise). An over-wing gravity filling point is provided in the wing upper skin. A sump at the low point in each tank contains a drain valve. Fuel is transferred from the auxiliary tank to its associated main tank by an ejector pump and transfer lines (refer to Maintenance Manual PSM 1-8-2 or PSM 1-83-2).

**1-00-00**

PAGE 3

OCT 10/90

**Boeing Canada**  
de Havilland Division  
**DASH 8 AIRCRAFT RECOVERY**

**THIS PAGE INTENTIONALLY LEFT BLANK**

**1-00-00**

**PAGE 4**

**OCT 10/90**

## DASH 8 AIRCRAFT RECOVERY

### AIRCRAFT DIMENSIONS

#### 1. Dimensions (Figure 1)

With the aircraft supported on its landing gear the main dimensions are as follows:

##### A. Overall Dimensions

Span	85 ft 0 in. (25.90 m)
Length	73 ft 0.125 in. (22.29 m)
*Height	24 ft 7 in. (7.49 m)
*Propeller Ground Clearance (Static)	3 ft 0.90 in. (.94 m)

##### B. Wings

Root Chord	8 ft 4 in. (2.54 m)
Tip Chord	4 ft 3 in. (1.30 m)
Aspect Ratio	12
Incidence	2 degrees
Dihedral	2-1/2 degrees

##### C. Horizontal Stabilizer and Elevators

Span	26 ft 0 in. (7.93 m)
Root Chord	6 ft 8 in. (2.03 m)
Tip Chord	4 ft 11 in. (1.50 m)
Aspect Ratio	4.489
Incidence	+1 degree
Dihedral	0 degrees

##### D. Vertical Stabilizer and Rudders

Height	13 ft 3 in. (4.04 m)
Root Chord	13 ft 3 in. (4.04 m)
Tip Chord	9 ft 9 in. (2.97 m)
Aspect Ratio	1.155

##### E. Fuselage

Width	Outside 8 ft 10 in. (2.69 m)
	Inside 8 ft 2 in. (2.49 m)
Height	Outside 8 ft 5 in. (2.57 m)
	Inside 6 ft 2 in. (1.88 m)

\* Dimensions to Ground Line are approximate only and vary depending on aircraft configuration and loading conditions.

**1-10-00**

# DASH 8 AIRCRAFT RECOVERY

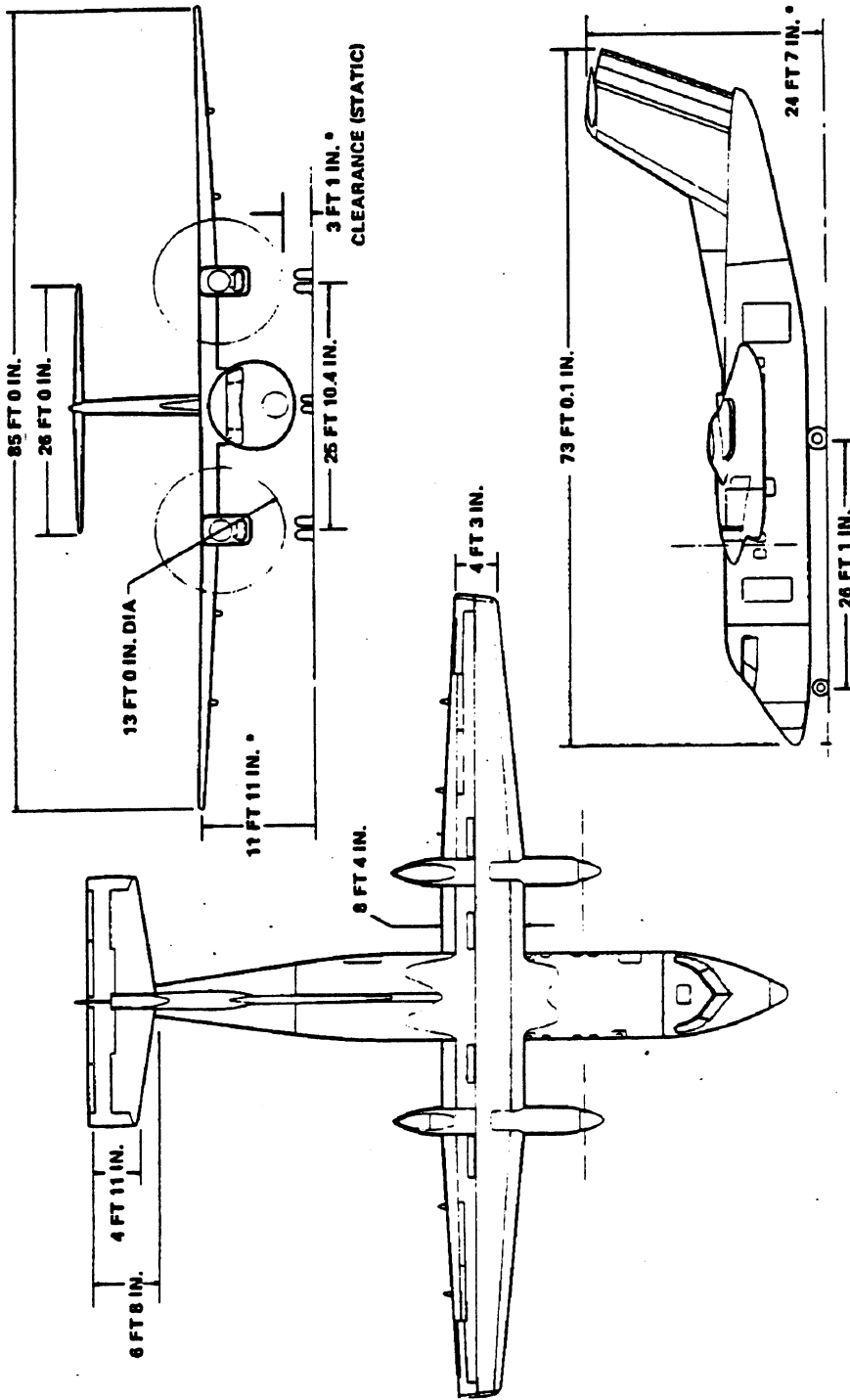

NOTE: DIMENSIONS TO GROUND LINE INDICATED \* ARE APPROXIMATE ONLY AND VARY DEPENDING ON LOADING CONDITIONS AND AIRCRAFT CONFIGURATION.

AIRCRAFT DIMENSIONS

FIGURE 1

1-10-00



**Boeing Canada**  
de Havilland Division  
**DASH 8 AIRCRAFT RECOVERY**

F. Landing Gear

Longitudinal dimension between main and nosewheel centers	26 ft 1 in. (7.95 m)
Main Wheel track	25 ft 10.4 in. (7.88 m)
Nosewheel Steering Angle	High Speed Taxi 14 degrees Slow Speed Taxi 120 degrees

G. Propeller

Diameter	13 ft 0 in. (3.96 m)
----------	----------------------

2. Areas

The main areas are as follows:

Wing	585 sq ft. (54.35 sq. m)
Horizontal Stabilizers and Elevators	150 sq ft. (13.94 sq. m)
Vertical Stabilizer and Rudders	152 sq ft. (14.12 sq. m)

**1-10-00**

PAGE 3

OCT 10/90

**Boeing Canada**  
de Havilland Division  
**DASH 8 AIRCRAFT RECOVERY**

**THIS PAGE INTENTIONALLY LEFT BLANK**

**1-10-00**

PAGE 4

OCT 10/90

**Boeing Canada**  
de Havilland Division  
**DASH 8 AIRCRAFT RECOVERY**

**AIRCRAFT STATIONS**

**1. General**

The aircraft stations and major structural components of the aircraft are located by a coordinate system using three main reference axes.

**2. Aircraft Coordinate System**

**A. General**

The three main reference axes are designated X, Y and Z and ordinates are located along these axes from a point of origin. The point of origin for the longitudinal axis X, lateral axis Y and vertical axis Z is in front of the aircraft and below the static ground line on the aircraft centerline (See Figure 1). Identification of the ordinates is by the dimension in inches from the point of origin prefixed by a letter denoting the axis, X 182.00 represents a position 182 inches (462.28 cm) along the X axis from the point of origin, which is located in front of aircraft nose (See Figure 2 Sheet 1).

**B. Major Assembly Datum Points**

Within the X, Y, Z axis system, additional points of origin are selected in the aircraft as datum points for locating major assemblies, i.e., wings, horizontal stabilizer and nacelles (See Figure 1). The ordinates in these areas are identified by the letter for the major axis with a suffix letter indicating the assembly, followed by the dimension in inches from the assembly point of origin, example: XN 55.00 represents a position 55.00 inches (139.7 cm) aft of the point of origin for the engine nacelle. This point of origin coincides with the basic aircraft ordinate X 312.00 (See Figure 4).

**C. Fuselage (Figure 2, Sheets 1 and 2)**

The fuselage components are located by dimensions along the X, Y and Z axis from the point of origin for the basic aircraft as described in sub-paragraph A.

**D. Vertical Stabilizer (Figure 3, Sheet 1)**

Vertical stabilizer is included in fuselage coordinate system.

**E. Horizontal Stabilizer (Figure 3, Sheet 2)**

The horizontal stabilizer assembly components are located by dimensions along the X axis from a point of origin XH 0.00 (aircraft ordinate X 866.15). Dimensions forward of XH 0.00 are negative. Along the Y axis dimensions are prefixed YH for identification although YH 0.00 is coincident with Y 0.00 on the aircraft centerline.

**1-20-00**

PAGE 1

OCT 10/90

Boeing Canada  
de Havilland Division  
**DASH 8 AIRCRAFT RECOVERY**

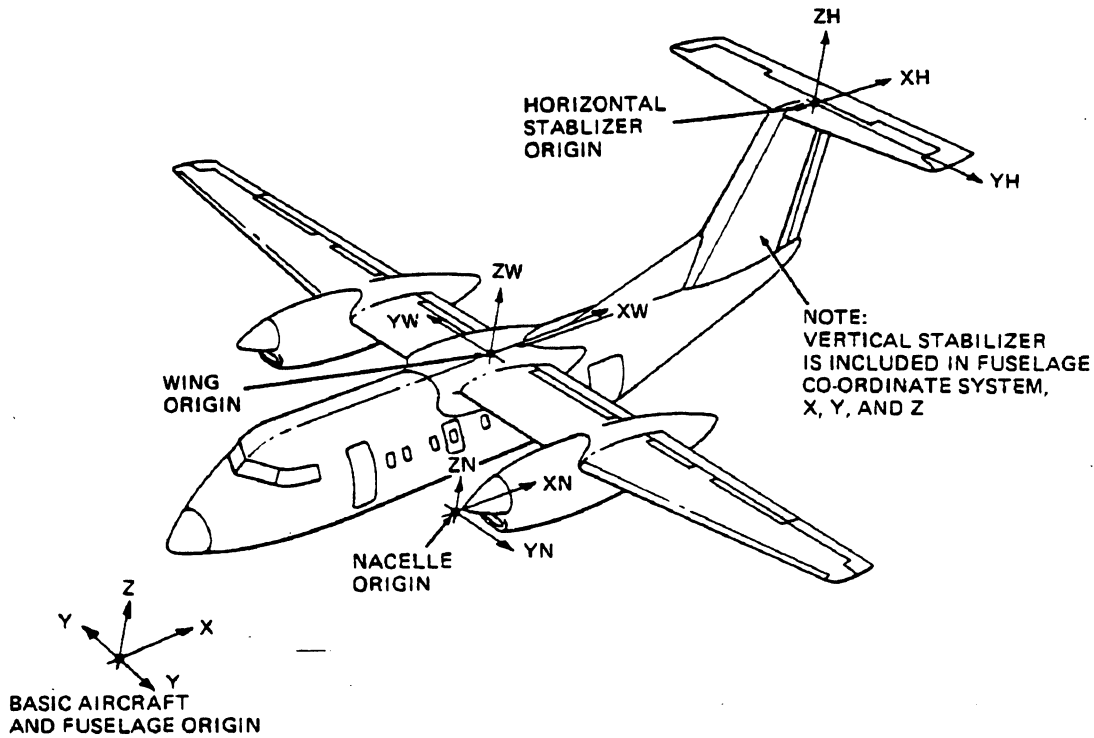

**AIRCRAFT CO-ORDINATE SYSTEM**

**FIGURE 1**

**F. Wings (Figure 4)**

The wing components are located by dimensions along the X axis from a point of origin XW 0.00 (aircraft ordinate X 426.97). Along the Y axis dimensions are prefixed YW for identification although YW 0.00 is coincident with Y 0.00 on the aircraft centerline (YC 0.00).

**G. Nacelles (Figure 5)**

The nacelle components are located by dimensions along the X axis from a point of origin XN 0.00 which is located 12.36 inches (31.394 cm) forward of the spinner tip and at aircraft ordinate X 257.00 and along Z axis from a point or origin ZN 0.00 (engine centerline) which is aircraft ordinate Z 171.90. Dimensions below ZN 0.00 are negative. The main landing gear support frame is located at XN 127.50 (aircraft ordinate X384.50).

**1-20-00**

**Boeing Canada**  
de Havilland Division  
**DASH 8 AIRCRAFT RECOVERY**

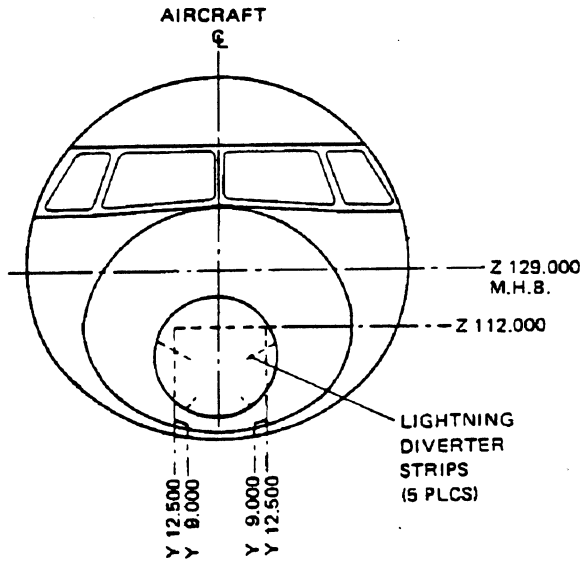
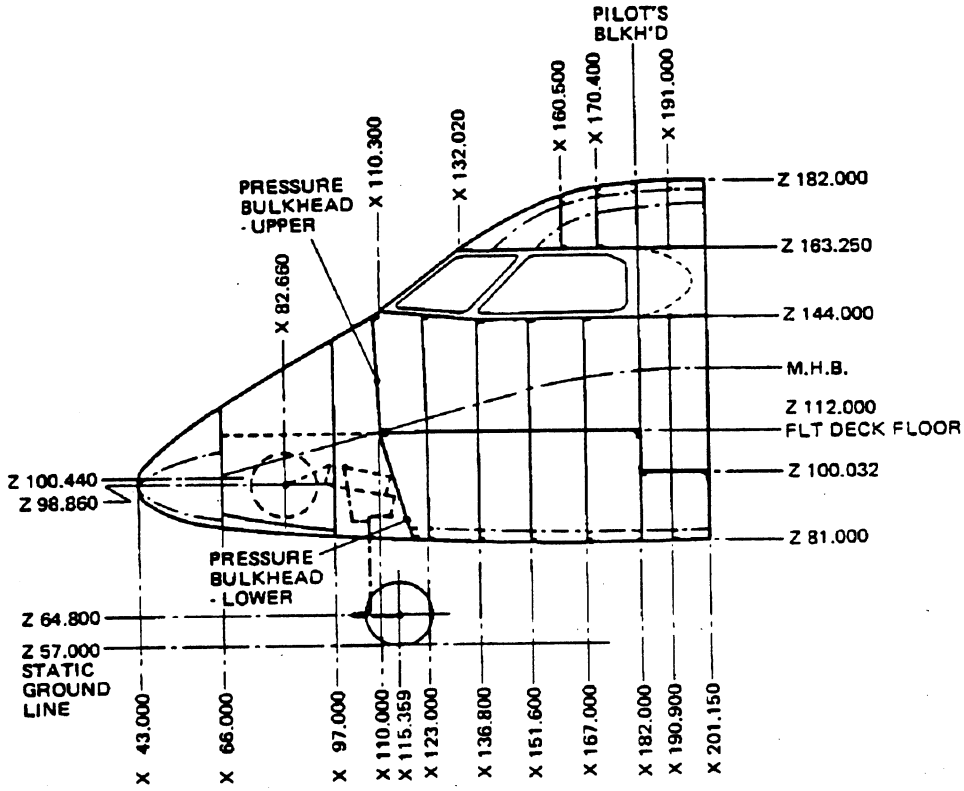

**FUSELAGE STATIONS DIAGRAM**

**FIGURE 2 (SHEET 1)**

**1-20-00**

DASH 8 AIRCRAFT RECOVERY

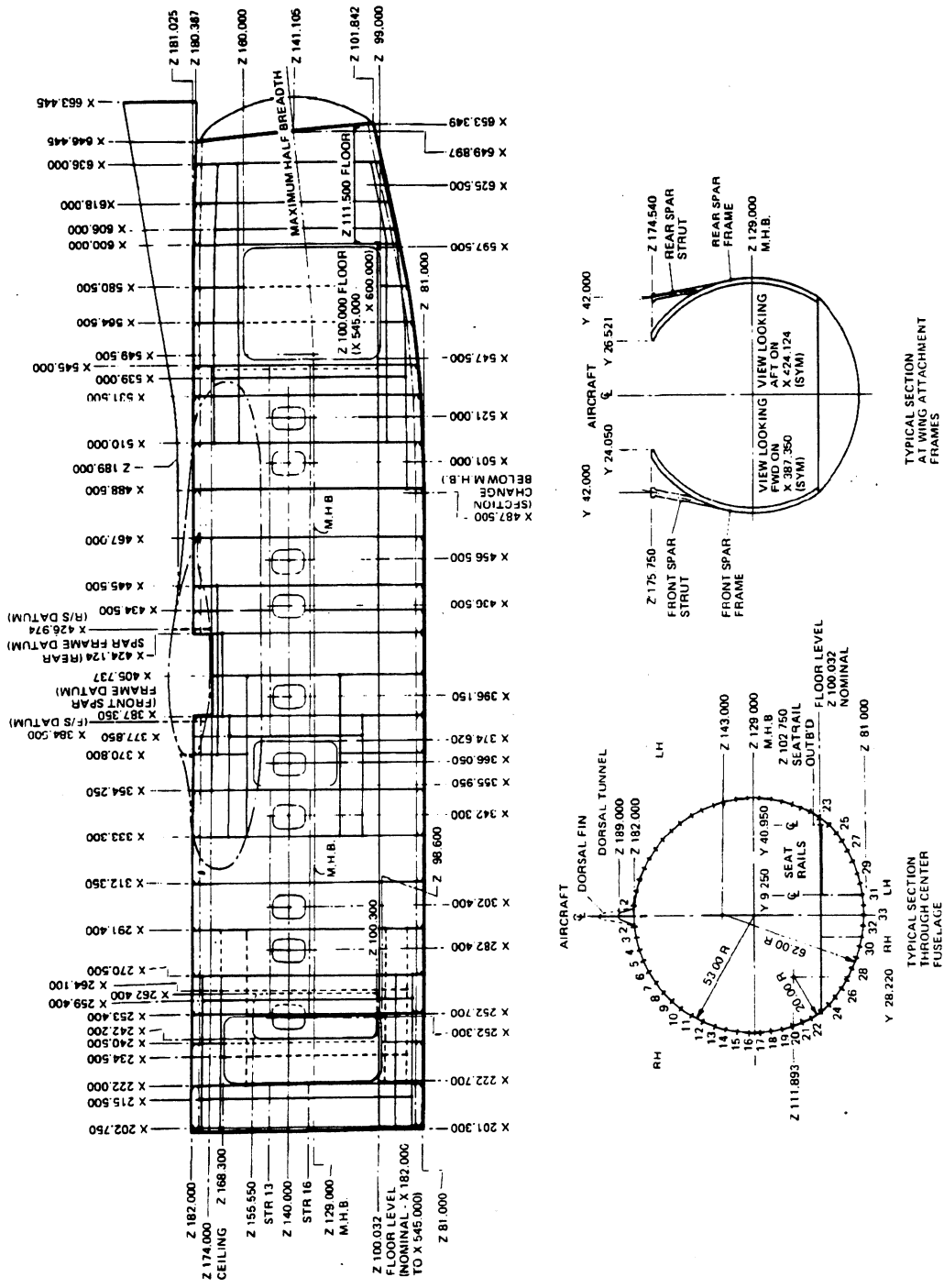

FUSELAGE STATIONS DIAGRAM

FIGURE 2 (SHEET 2)

1-20-00

DASH 8 AIRCRAFT RECOVERY

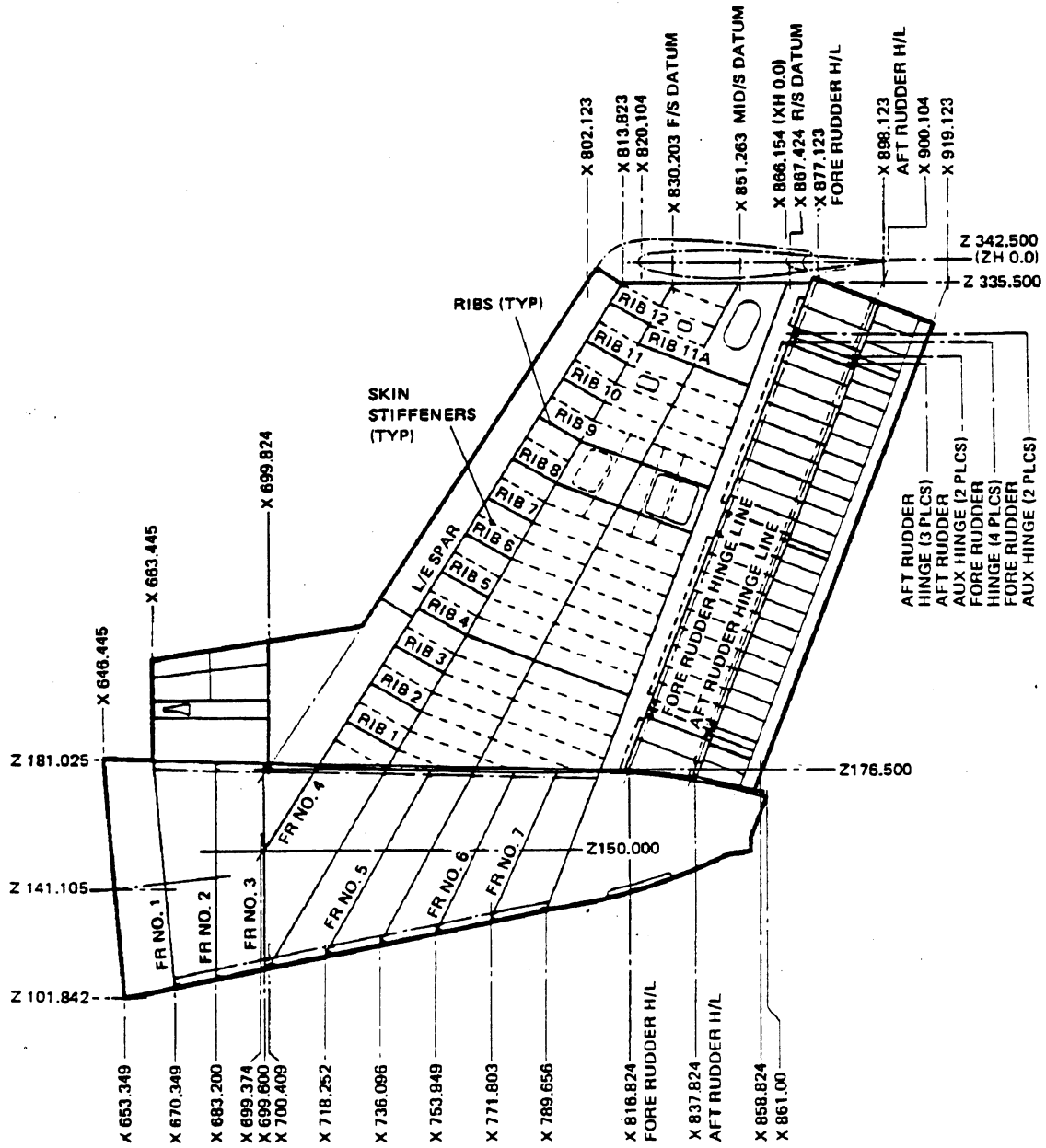

STABILIZERS STATIONS DIAGRAM

FIGURE 3 (SHEET 1)

1-20-00

**Boeing Canada**  
de Havilland Division  
**DASH 8 AIRCRAFT RECOVERY**

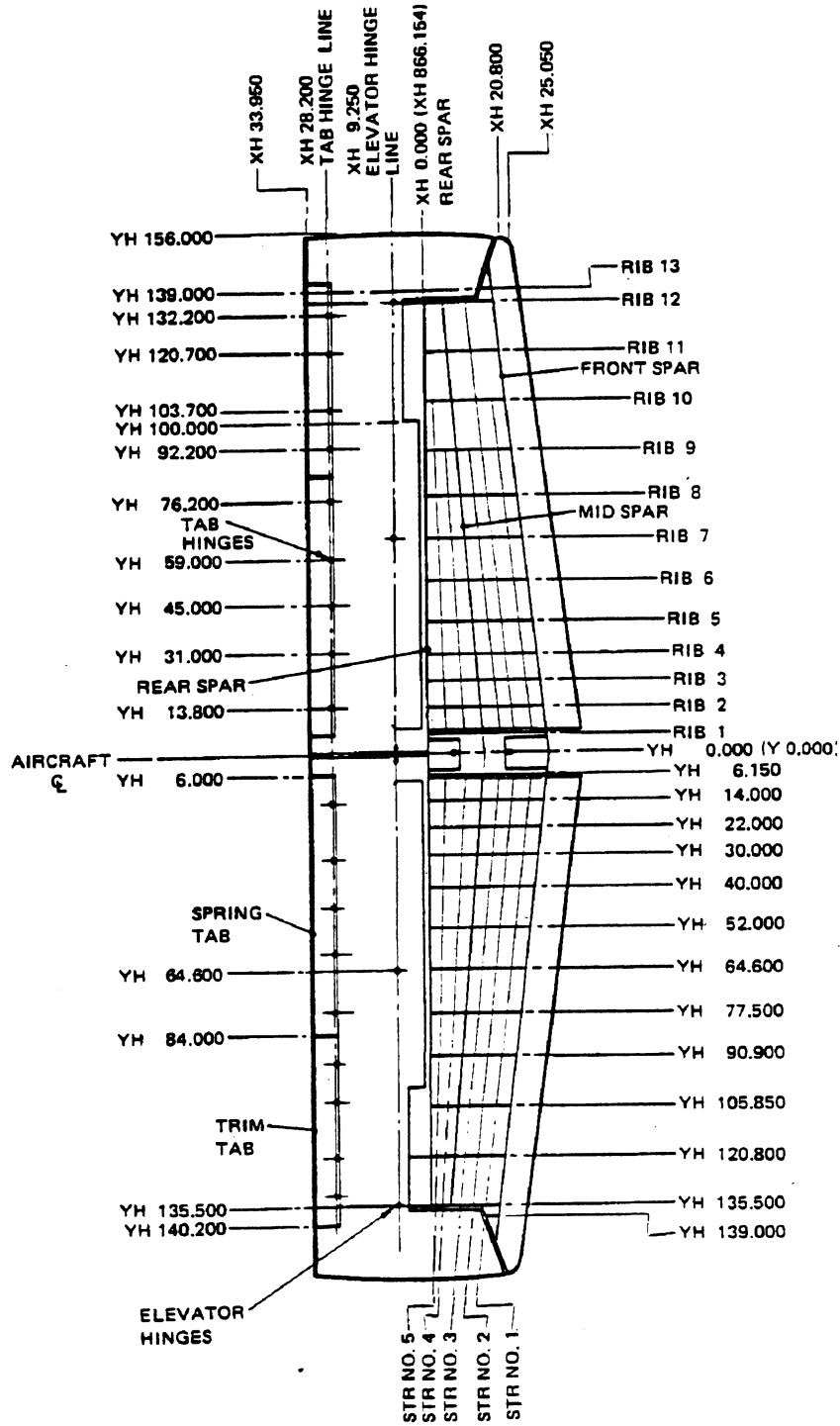

**STABILIZERS STATIONS DIAGRAM**

**FIGURE 3 (SHEET 2)**

**1-20-00**





DASH 8 AIRCRAFT RECOVERY

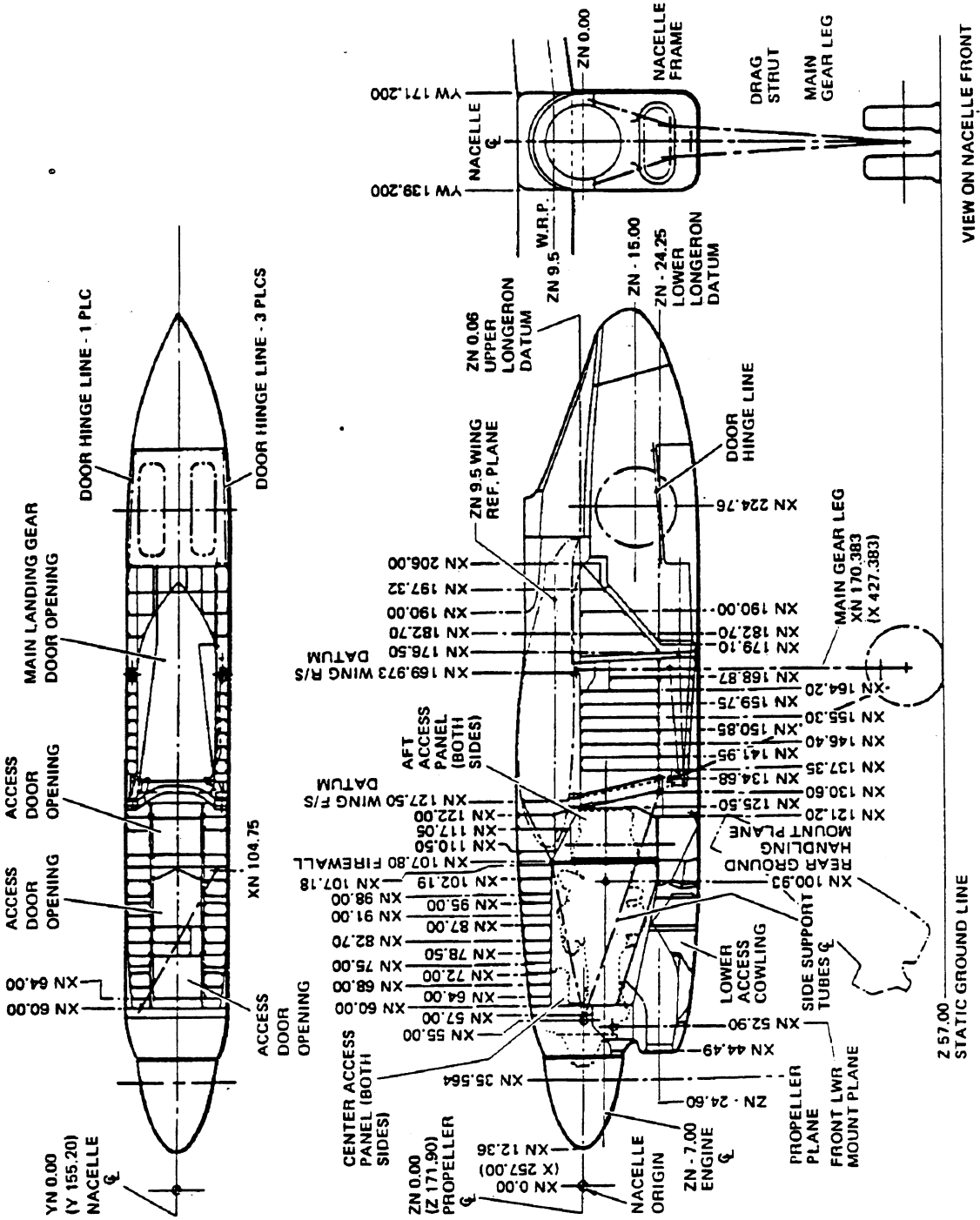

NACELLES STATIONS DIAGRAM

FIGURE 5

1-20-00

**Boeing Canada**  
de Havilland Division  
**DASH 8 AIRCRAFT RECOVERY**

**AIRCRAFT SERVICING POINTS**

**1. General**

Maintenance Manual PSM 1-8-2 and PSM 1-83-2 Chapter 12 Servicing or Ramp Servicing Manual PSM 1-8-2S and PSM 1-83-2S Part 4 provide descriptions and illustrations to aid in locating system or component service points.

Plan and side view Service Points are shown in Figure 1, other service points shown in Figure 2.

**1-30-00**

PAGE 1

OCT 10/90

Boeing Canada  
de Havilland Division  
**DASH 8 AIRCRAFT RECOVERY**

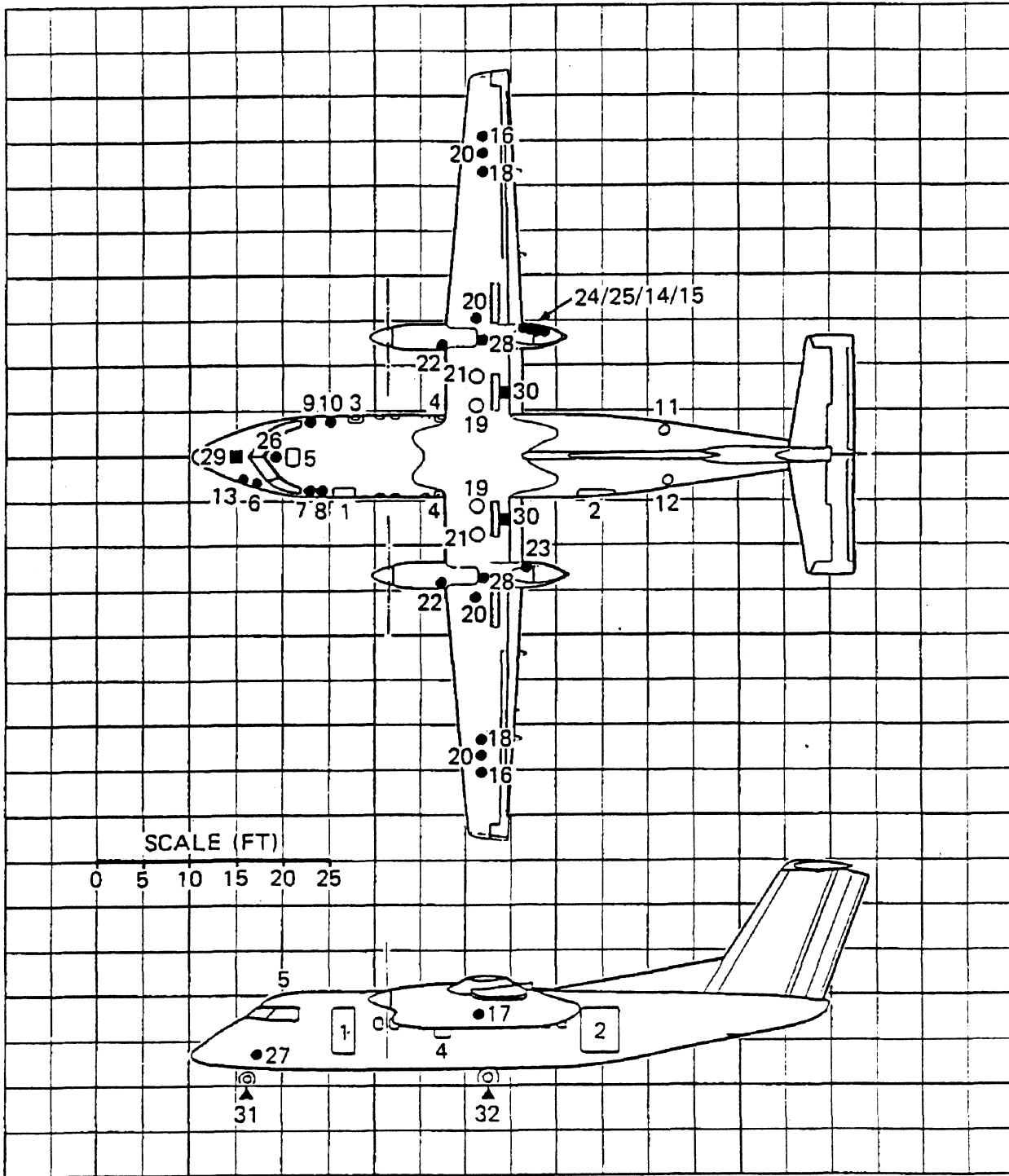

GROUND SERVICING  
FIGURE 1 (SHEET 1)

**1-30-00**

**DASH 8 AIRCRAFT RECOVERY**

KEY

1. AIRSTAIR DOOR
2. CARGO DOOR
3. TYPE II EMERGENCY EXIT
4. TYPE III EMERGENCY EXIT
5. FLIGHT COMPARTMENT EMERGENCY EXIT
6. INTERPHONE CONNECTION
7. AVIONICS BAY
8. WARDROBE
9. LAVATORY
10. GALLEY
11. APU & SERVICING PANEL (SOO 8099)
12. AIR CONDITIONING GROUND CONNECTION  
(SOO 8069) – ON RH SIDE IF NO APU
13. ELECTRICAL DC POWER RECEPTACLE
14. ELECTRICAL AC POWER RECEPTACLE
15. PRESSURE REFUELING PANEL & GROUNDING  
POINT
16. GROUNDING POINT (OVERWING)
17. GROUNDING POINT (ON U/C DRAG STRUT  
CROSSBEAM – BOTH SIDES)
18. GRAVITY FUEL FILLER (OVERWING)
19. AUX. TANK GRAVITY FUEL FILLER
20. MAGNASTICK (FUEL CONTENTS – UNDERWING)
21. AUX. TANK MAGNASTICK
22. ENGINE OIL FILLER PANEL
23. NO. 1 HYDRAULIC SYSTEM
24. NO. 2 HYDRAULIC SYSTEM
25. BRAKE ACCUMULATOR AIR CHARGING POINTS  
& HYDRAULIC HANDPUMP
26. EMERGENCY LANDING GEAR HYDRAULIC  
RESERVOIR & HANDPUMP
27. NOSE GEAR SHOCK STRUT AIR CHARGING  
POINTS
28. MAIN GEAR SHOCK STRUT AIR CHARGING  
POINTS (UNDER NACELLE)
29. NOSE JACKING POINT
30. WING JACKING POINT
31. NOSE GEAR JACKING POINT
32. MAIN GEAR JACKING POINT

GROUND SERVICING

FIGURE 2 (SHEET 2)

**1-30-00**

PAGE 3

OCT 10/90

**Boeing Canada**  
de Havilland Division  
**DASH 8 AIRCRAFT RECOVERY**

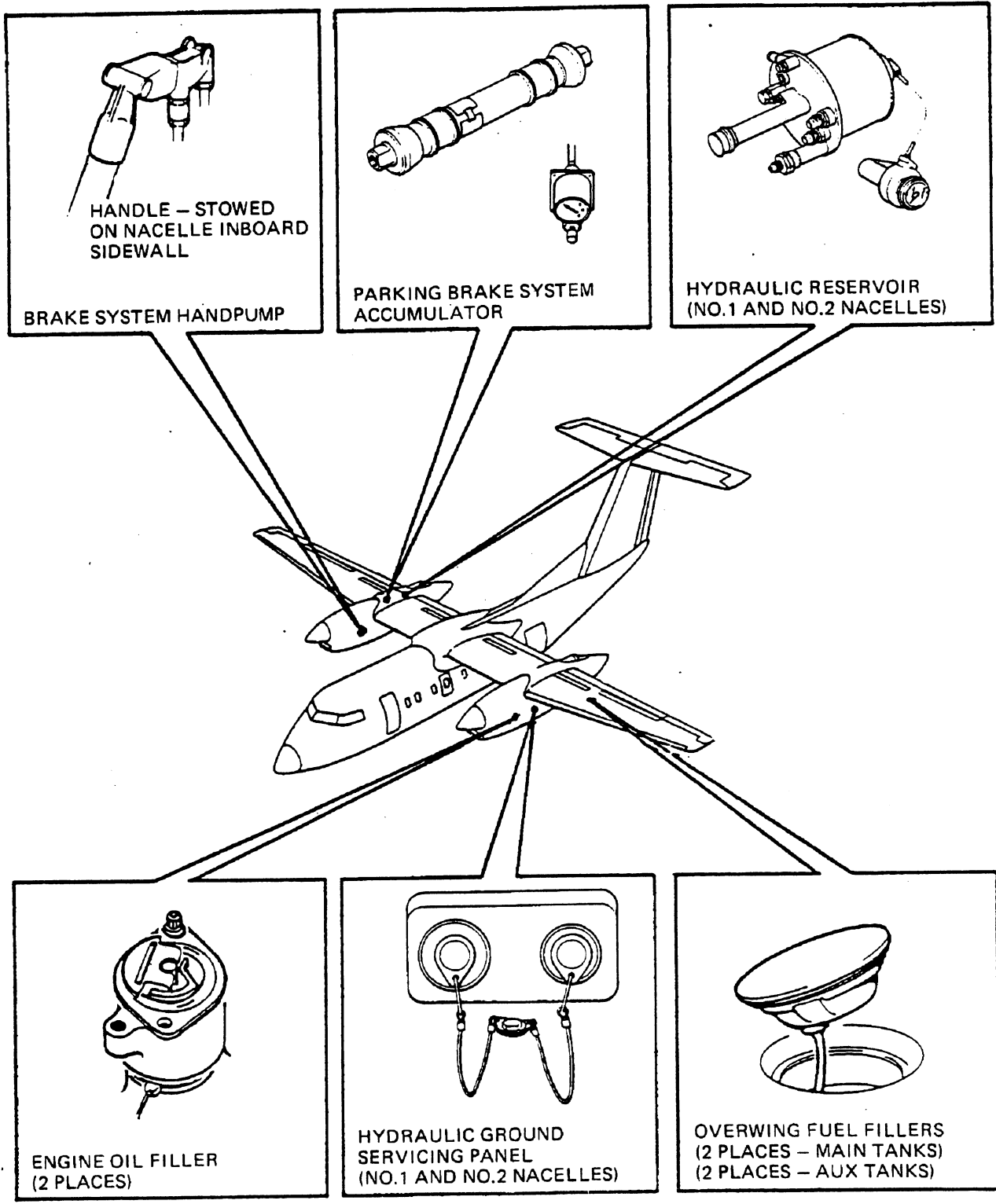

**AIRCRAFT SERVICING POINTS**

**FIGURE 2 (SHEET 1)**

**1-30-00**

DASH 8 AIRCRAFT RECOVERY

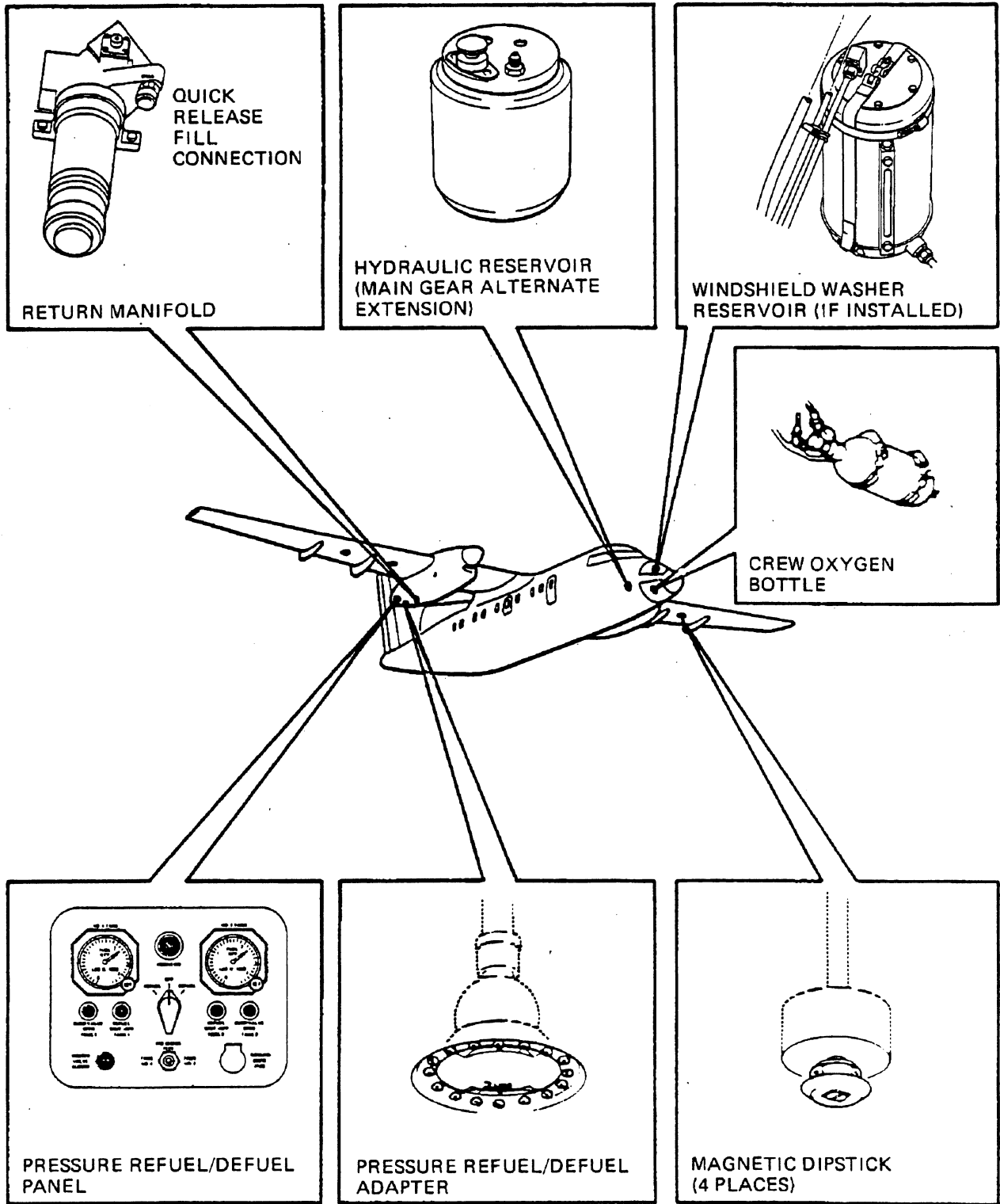

AIRCRAFT SERVICING POINTS

FIGURE 2 (SHEET 2)

1-30-00

DASH 8 AIRCRAFT RECOVERY

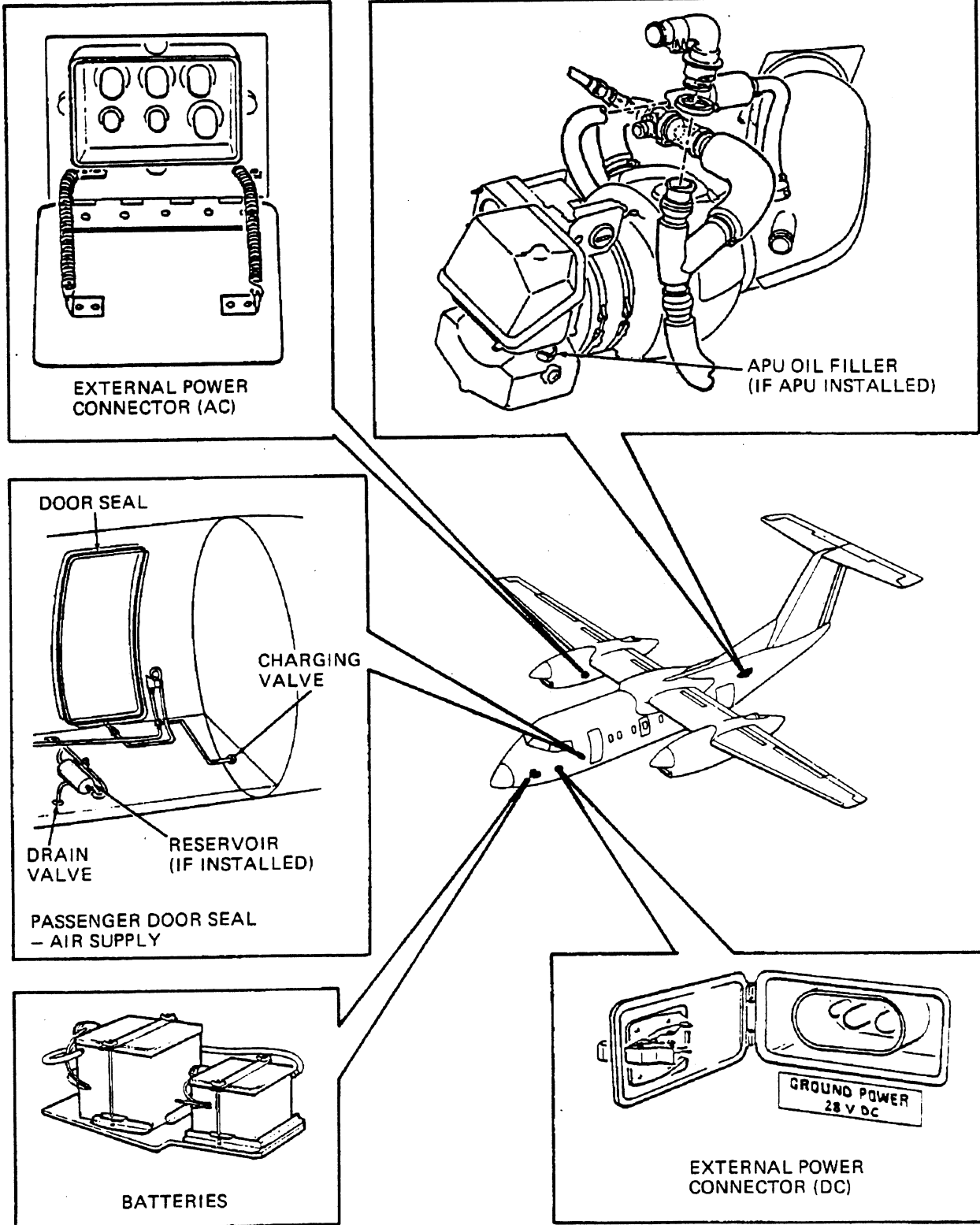

AIRCRAFT SERVICING POINTS

FIGURE 2 (SHEET 3)

1-30-00



## **DASH 8 AIRCRAFT RECOVERY**

### **DOORS - GENERAL**

#### **1. General (Figure 1)**

An airstair door (Figure 2) is located on the left side of the fuselage at the front of the passenger compartment and provides access to and from the aircraft for passengers and crew during normal use. The door incorporates stairs and an inflatable seal is installed on the fuselage structure around the edge of the door opening.

Two Type III emergency exit doors are provided, one on each side of the fuselage forward of the wing, and one Type II emergency exit door is provided on the right side of the fuselage, opposite the passenger door. A flight compartment escape hatch door for the flight crew is located in the canopy roof of the flight compartment. A door located in the passenger compartment forward bulkhead provides access to the flight compartment. (Figure 3)

External access to the baggage compartment is through a door located on the left side of the fuselage (Figure 4). An access door, located in the passenger compartment rear bulkhead provides access to the baggage compartment from inside the aircraft if required.

For maintenance purposes, service doors are installed at various locations on the aircraft. A rear fuselage access door is located on the underside of the rear fuselage between Stations X708.00 and X728.00. Access to the refuel/defuel panel is by a door in the rear of No. 2 engine nacelle, and a lavatory service door is located in the right side of the fuselage at station X212.00. Four doors, two each side of the fuselage forward of the flight compartment provide access to the nose compartment.

The airstair door and external baggage compartment door are monitored by a door warning system to provide a visual indication in the flight compartment of a door unlocked condition.

**DASH 8 AIRCRAFT RECOVERY**

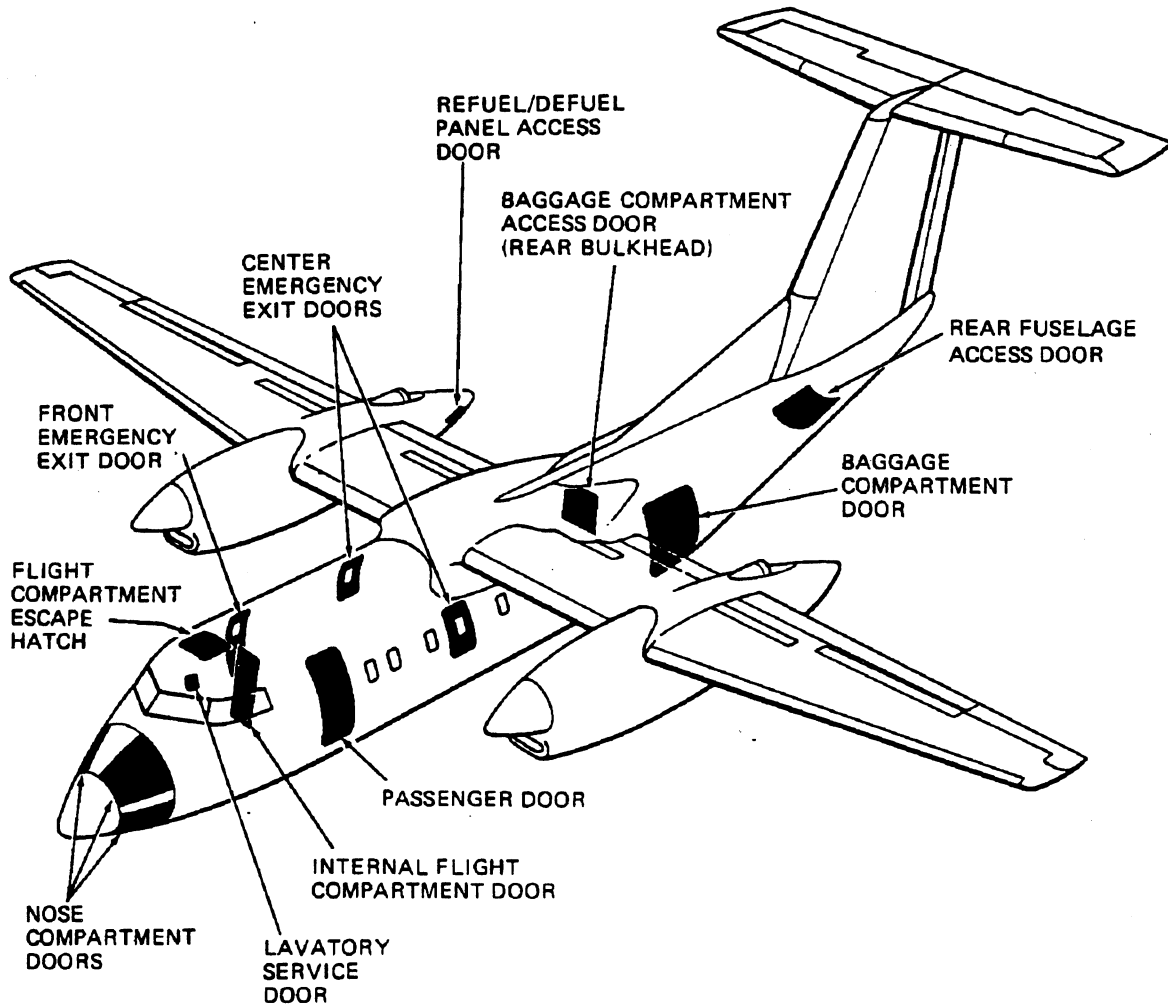

**AIRCRAFT DOORS**

**FIGURE 1**

**1-40-00**

# DASH 8 AIRCRAFT RECOVERY

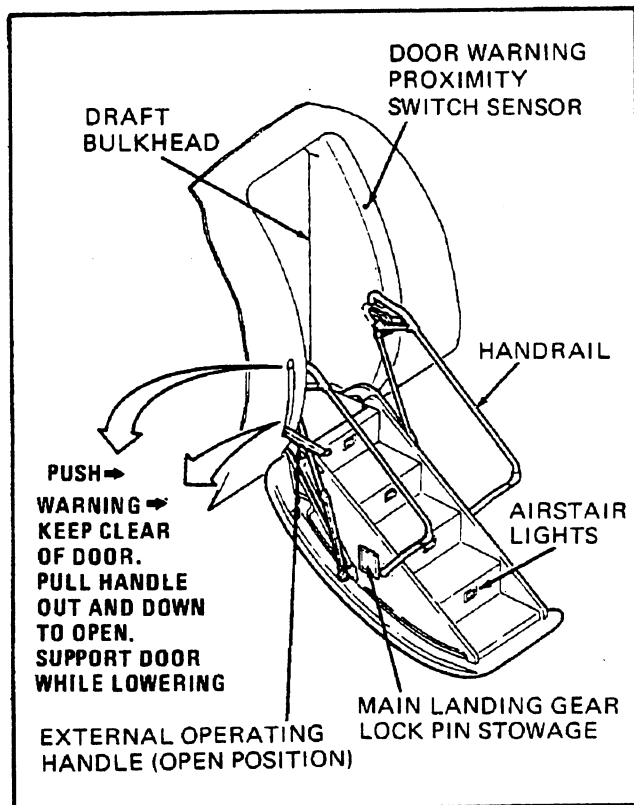
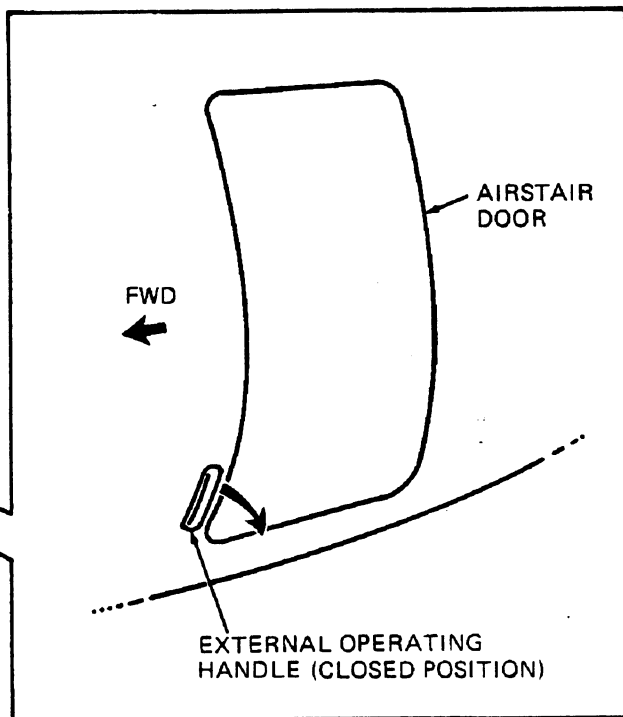
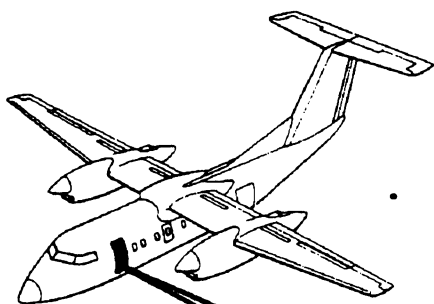

## OPEN AIRSTAIR DOOR

TO OPEN AIRSTAIR DOOR, STAND CLEAR OF DOOR AND PULL OPERATING HANDLE SHARPLY DOWN TO FULLEST EXTENT. (THIS WILL UNLOCK DOOR AND DISPLACE IT OUTWARD).

GRASP DOOR AND LOWER TO DOWN POSITION.

PUSH DOWN ON HANDRAIL UNTIL STRUTS ARE RIGID TO LOCK DOOR IN DOWN POSITION.

## CLOSE AIRSTAIR DOOR

LIFT HANDRAIL TO UNLOCK STRUTS.

LIFT UP DOOR PUSHING SHARPLY TO CLOSED POSITION.

RETURN OPERATING HANDLE TO STOWED POSITION.

AIRSTAIR DOOR - OPEN AND CLOSE (EXTERIOR)

FIGURE 2 (SHEET 1)

1-40-00

**DASH 8 AIRCRAFT RECOVERY**

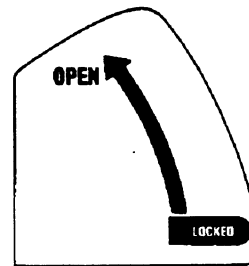
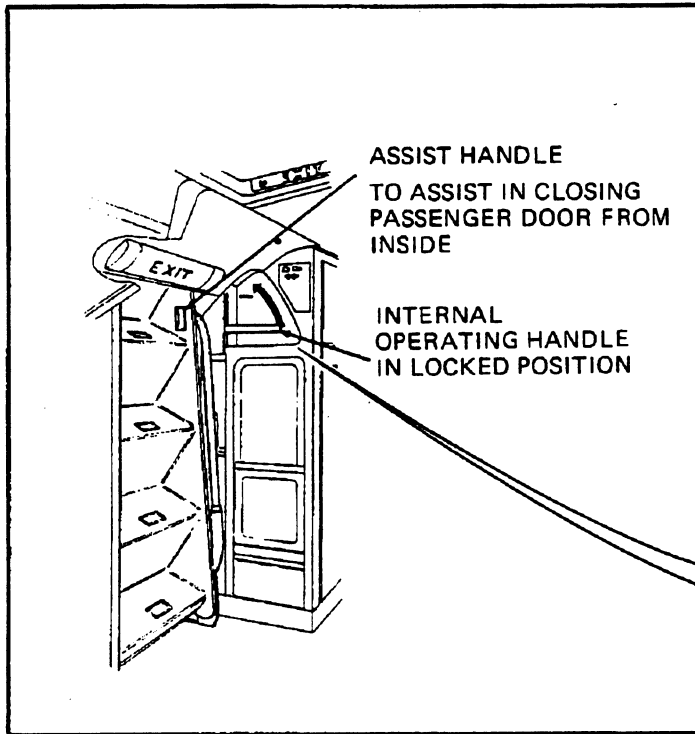

**PASSENGER DOOR CLOSED**

**OPEN AIRSTAIR DOOR**

TO OPEN AIRSTAIR DOOR, LIFT  
INTERNAL OPERATING HANDLE  
TO FULLEST EXTENT.

PUSH AIRSTAIR OUTWARD.

LOCK AIRSTAIR INTO FULLY  
DOWN POSITION BY PUSHING ON  
AIRSTAIR UNTIL HANDRAIL  
STRUTS ARE RIGID.

**CLOSE AIRSTAIR DOOR**

LIFT HANDRAIL AND PULL IN  
AIRSTAIR DOOR TO FULLY  
CLOSED POSITION.

PUSH DOWN OPERATING HANDLE  
TO FULLY LOCKED POSITION.

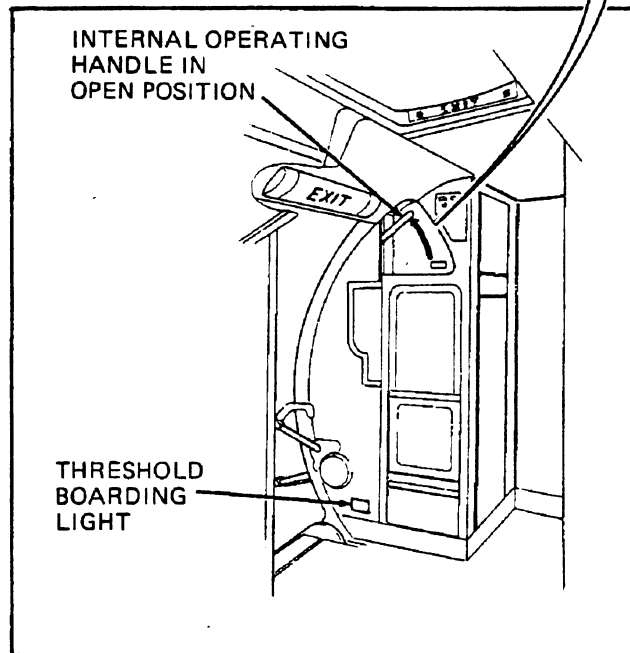

**PASSENGER DOOR OPEN**

**AIRSTAIR DOOR - OPEN AND CLOSE (INTERIOR)**

**FIGURE 2 (SHEET 2)**

**1-40-00**

DASH 8 AIRCRAFT RECOVERY

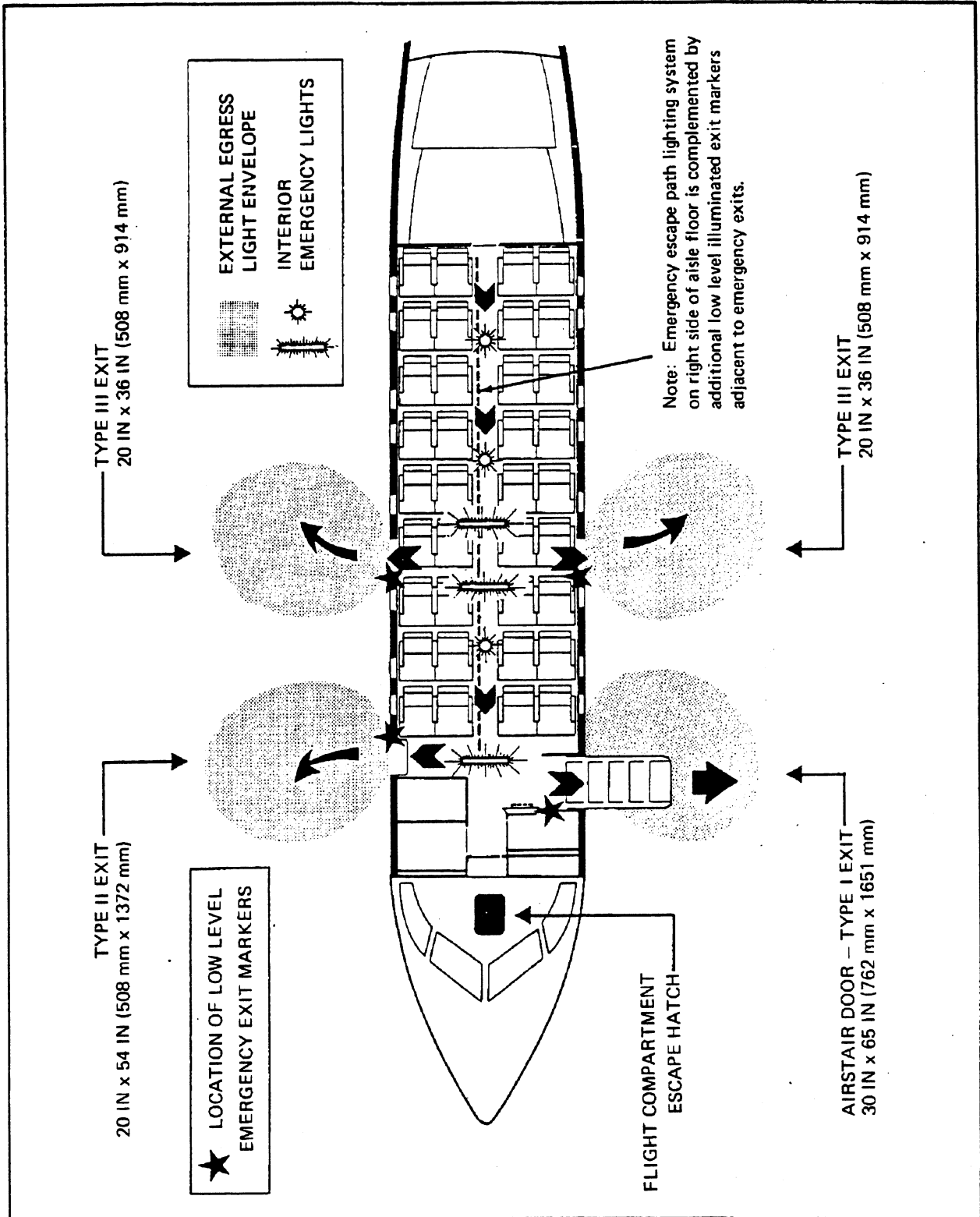

EMERGENCY EXITS AND LIGHTING

FIGURE 3 (SHEET 1)

1-40-00

# DASH 8 AIRCRAFT RECOVERY

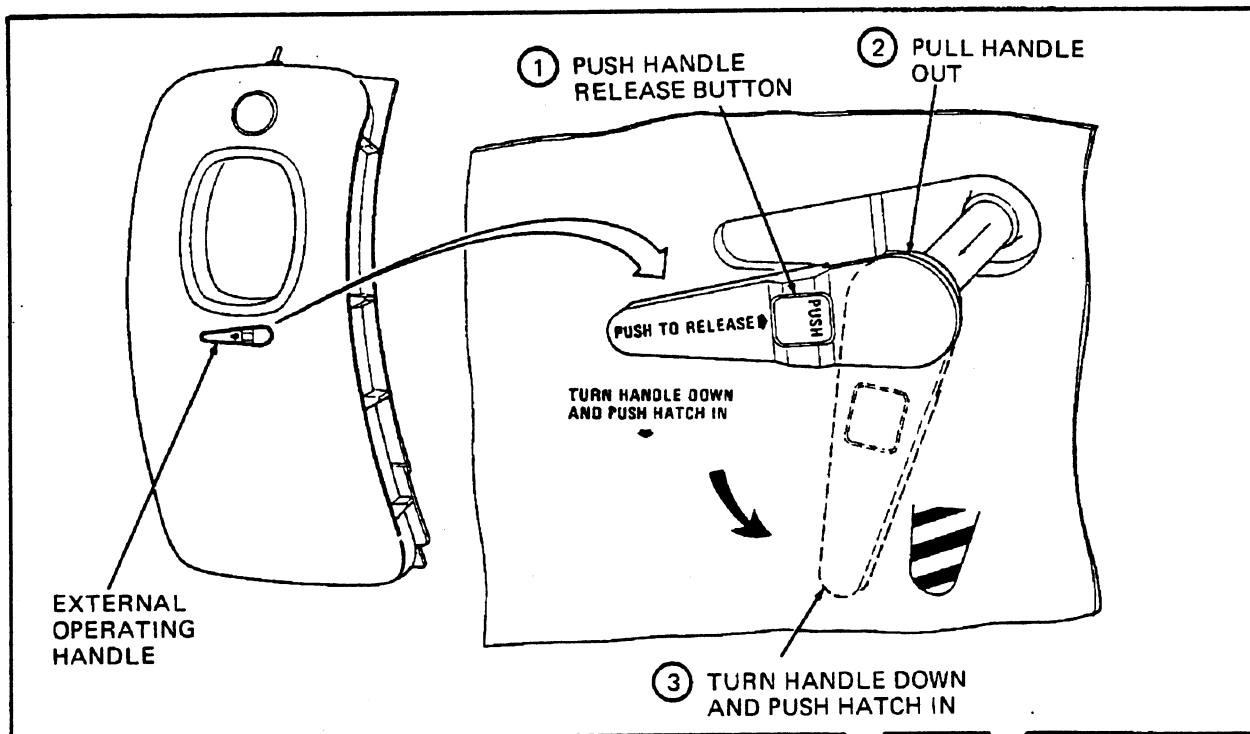

EXTERNAL DOOR OPENING –  
TYPE II AND TYPE III EXITS

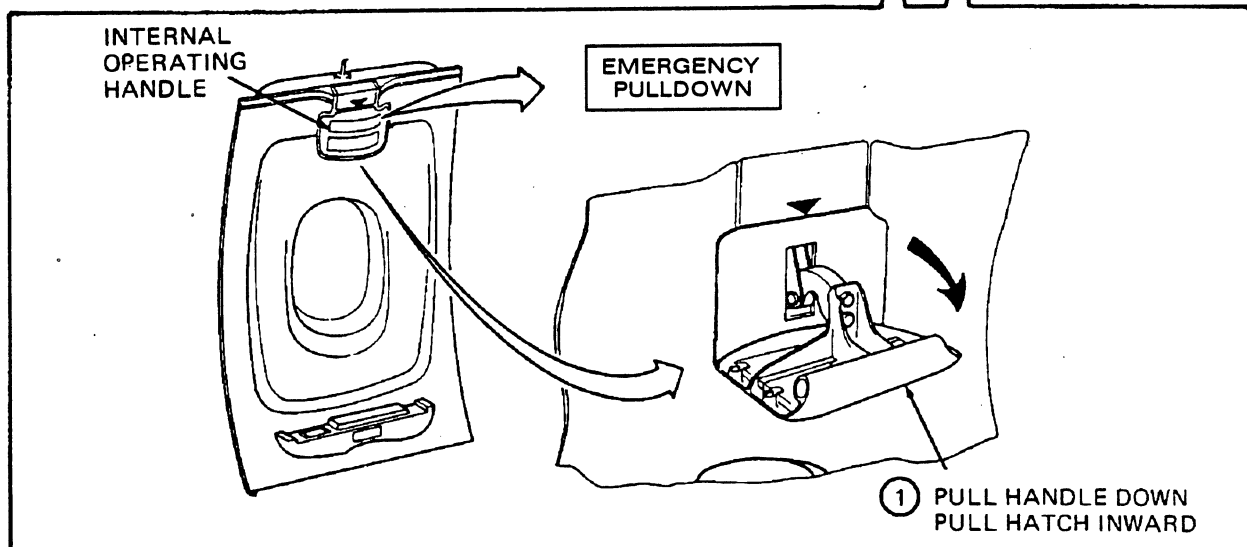
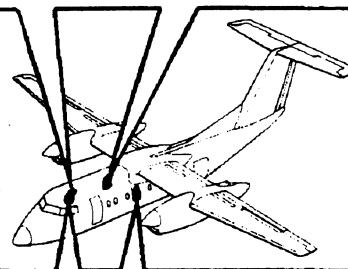

INTERNAL DOOR OPENING – TYPE II AND TYPE III EXITS

## EMERGENCY EXIT DOORS - OPENING

FIGURE 3 (SHEET 2)

1-40-00

# DASH 8 AIRCRAFT RECOVERY

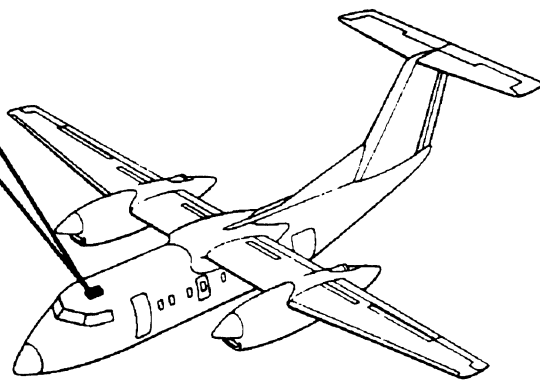
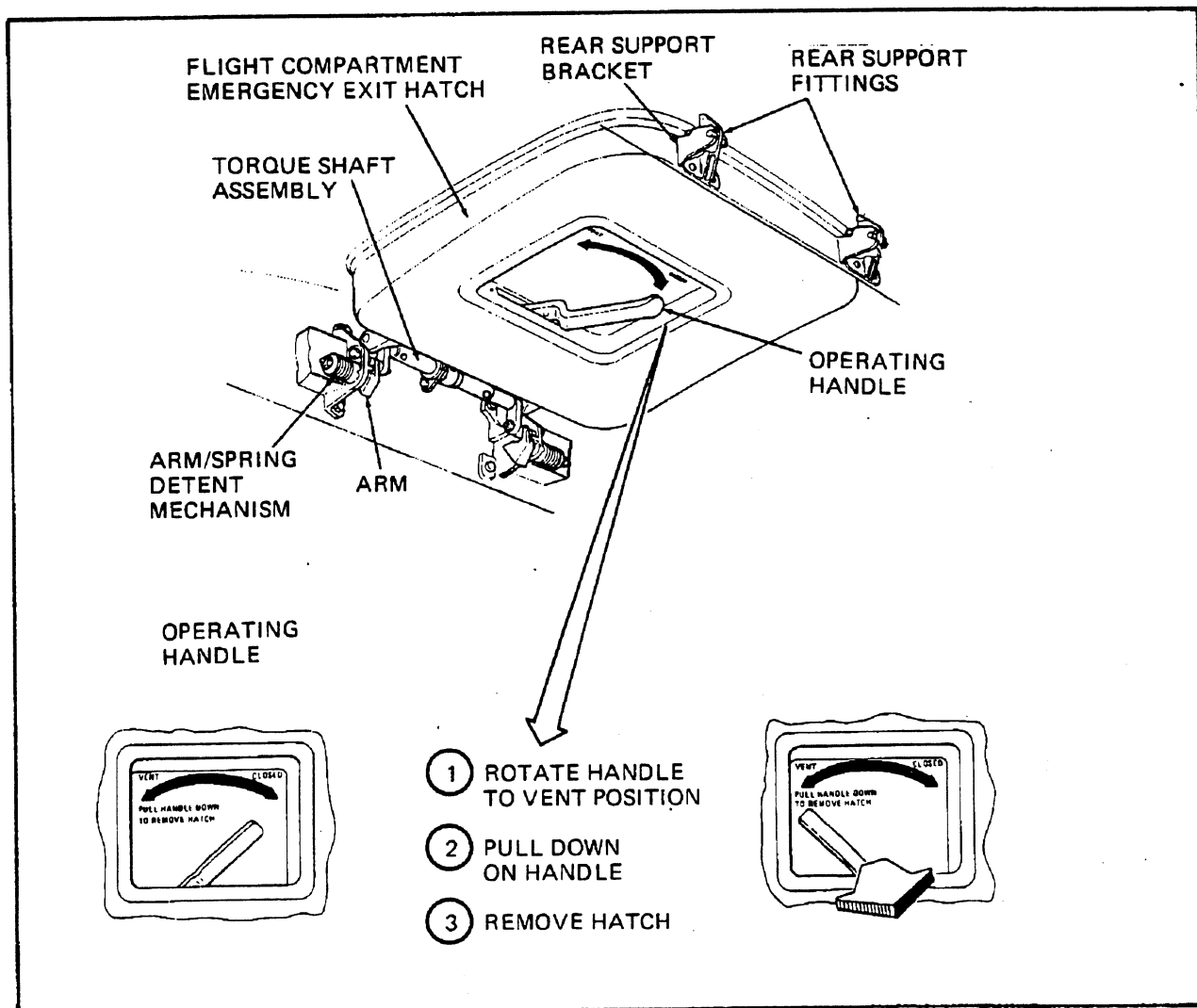

FLIGHT COMPARTMENT ESCAPE HATCH

FIGURE 3 (SHEET 3)

1-40-00

DASH 8 AIRCRAFT RECOVERY

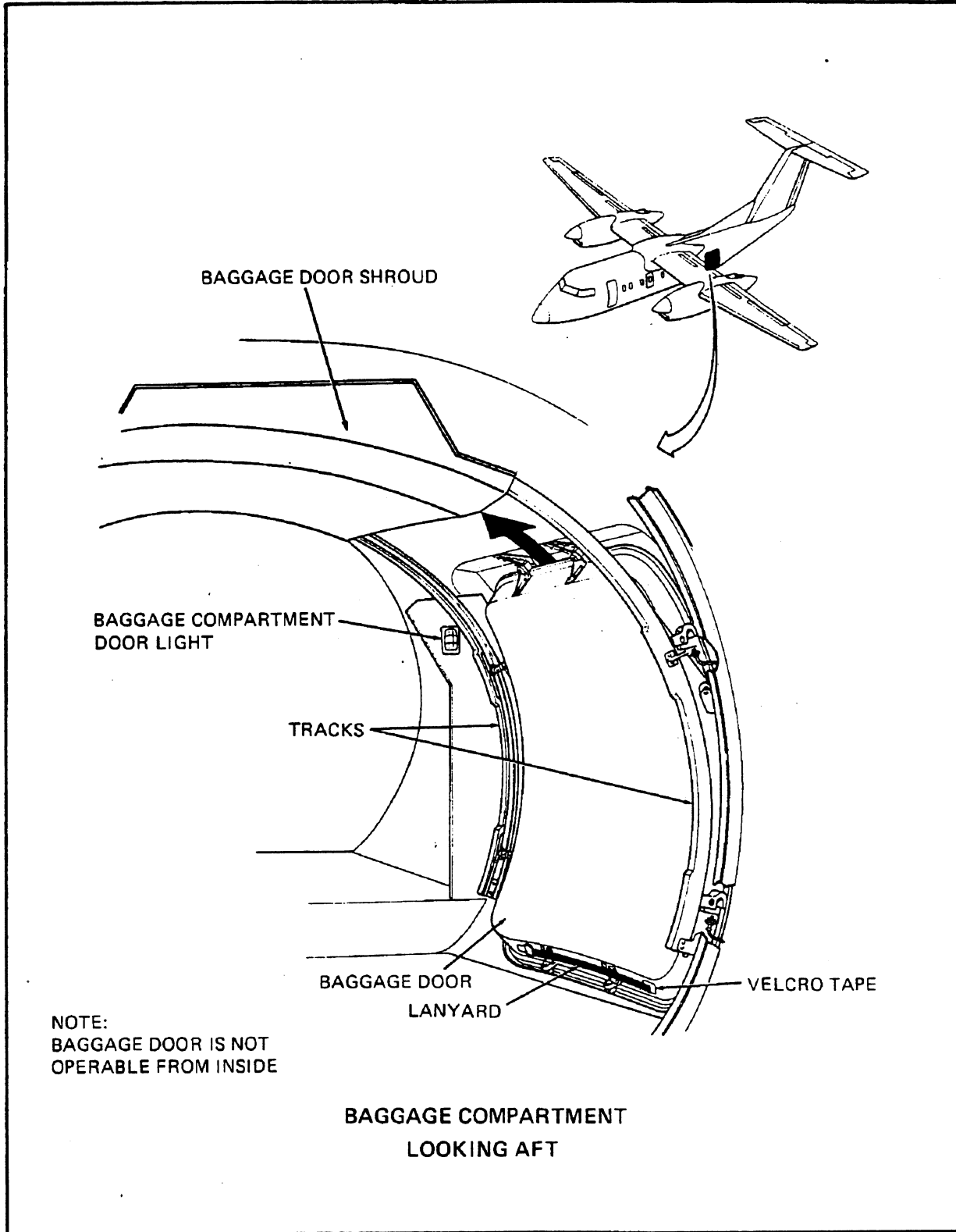

BAGGAGE DOOR - OPEN AND CLOSE - SHEET 1

FIGURE 4 (SHEET 1)

1-40-00



# DASH 8 AIRCRAFT RECOVERY

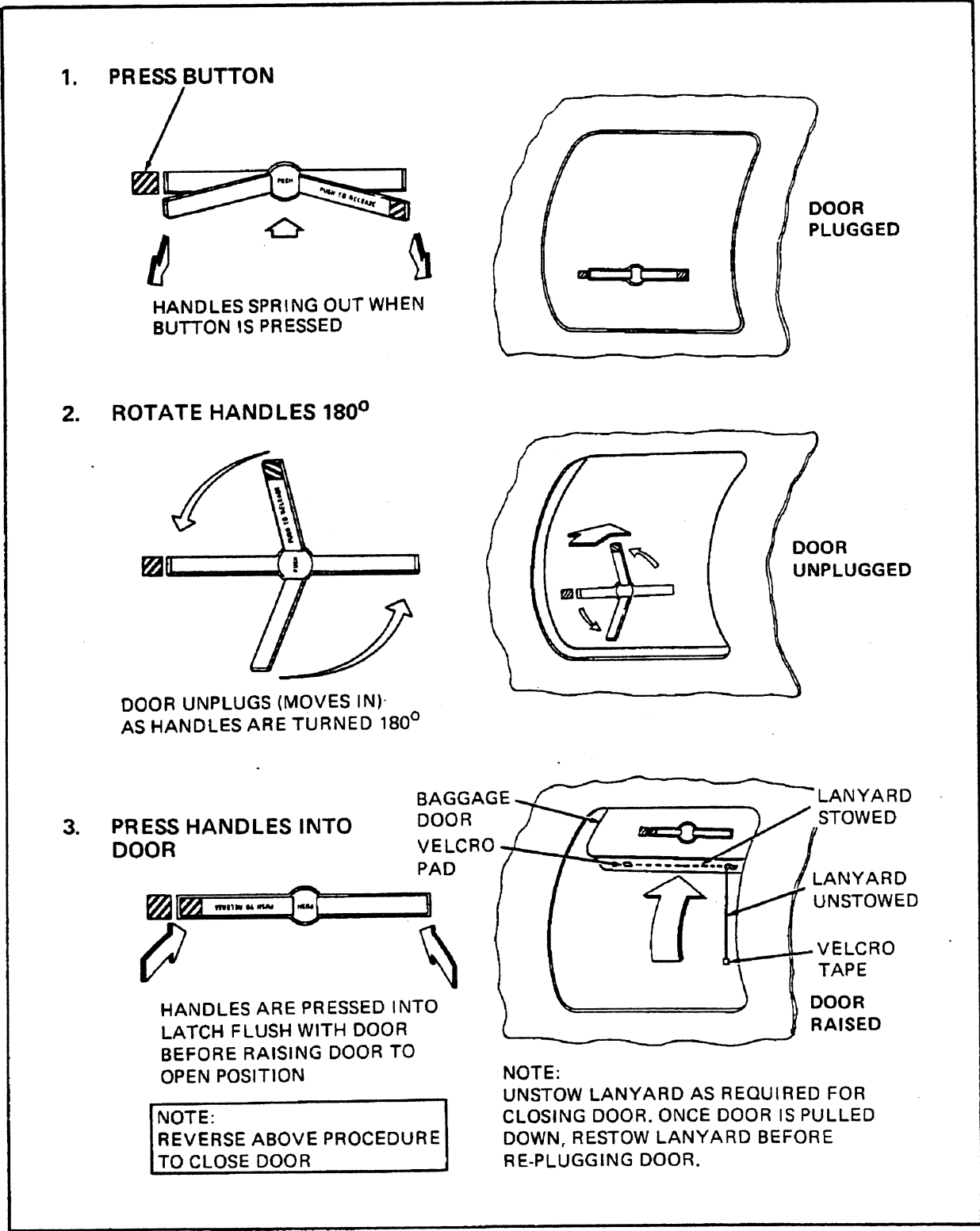

BAGGAGE DOOR - OPEN AND CLOSE

FIGURE 4 (SHEET 2)

1-40-00

**Boeing Canada**  
de Havilland Division  
**DASH 8 AIRCRAFT RECOVERY**

**THIS PAGE INTENTIONALLY LEFT BLANK**

**1-40-00**

PAGE 10

OCT 10/90

**Boeing Canada**  
de Havilland Division

**DASH 8 AIRCRAFT RECOVERY**

**LIST OF EFFECTIVE PAGES: CHAPTER 2: SURVEY AND PREPARATION**

Reference	Page	Date	Reference	Page	Date
CONTENTS	1	Oct 10/90	2-30-01	1	Oct 10/90
	2	Oct 10/90		2	Oct 10/90
2-00-00	1	Oct 10/90		3	Oct 10/90
	2	Oct 10/90		4	Oct 10/90
	3	Oct 10/90		5	Oct 10/90
	4	Oct 10/90		6	Oct 10/90
2-10-00	1	Oct 10/90		7	Oct 10/90
	2	Oct 10/90		8	Oct 10/90
2-10-01	1	Oct 10/90		9	Oct 10/90
	2	Blank		10	Blank
2-10-02	1	Oct 10/90	2-30-02	1	Oct 10/90
	2	Oct 10/90		2	Oct 10/90
2-10-03	1	Oct 10/90		3	Oct 10/90
	2	Blank		4	Oct 10/90
2-10-04	1	Oct 10/90		5	Oct 10/90
	2	Oct 10/90		6	Oct 10/90
2-20-00	1	Oct 10/90	2-30-03	1	Oct 10/90
	2	Blank		2	Oct 10/90
2-20-01	1	Oct 10/90		3	Oct 10/90
	2	Oct 10/90		4	Oct 10/90
	3	Oct 10/90		5	Oct 10/90
	4	Blank		6	Oct 10/90
2-20-02	1	Oct 10/90		7	Oct 10/90
	2	Blank		8	Oct 10/90
2-20-03	1	Oct 10/90		9	Oct 10/90
	2	Oct 10/90		10	Oct 10/90
	3	Oct 10/90		11	Oct 10/90
	4	Oct 10/90		12	Oct 10/90
	5	Oct 10/90	2-30-04	1	Oct 10/90
	6	Oct 10/90		2	Oct 10/90
2-30-00	1	Oct 10/90		3	Oct 10/90
	2	Blank		4	Oct 10/90
				5	Oct 10/90
				6	Oct 10/90
			7	Oct 10/90	
			8	Oct 10/90	
			9	Oct 10/90	
			10	Oct 10/90	

The asterisk (\*) indicates pages revised, added or deleted by current revision.

**2-EFFECTIVE PAGES**

**Boeing Canada**  
de Havilland Division

**DASH 8 AIRCRAFT RECOVERY**

**LIST OF EFFECTIVE PAGES: CHAPTER 2: SURVEY AND PREPARATION (CONT'D)**

<b>Reference</b>	<b>Page</b>	<b>Date</b>	<b>Reference</b>	<b>Page</b>	<b>Date</b>
2-30-05	1	Oct 10/90			
	2	Oct 10/90			
	3	Oct 10/90			
	4	Oct 10/90			
	5	Oct 10/90			
	6	Blank			

The asterisk (\*) indicates pages revised, added or deleted by current revision.

**2-EFFECTIVE PAGES**

**Boeing Canada**  
de Havilland Division

**DASH 8 AIRCRAFT RECOVERY**

**CHAPTER 2 - SURVEY AND PREPARATION**

**TABLE OF CONTENTS**

<b>Subject</b>	<b>Chapter Section Subject</b>	<b>Page</b>
<b>SURVEY AND PREPARATION</b>	<b>2-00-00</b>	
General		1
Advance Planning		
<b>DAMAGE AND TERRAIN</b>	<b>2-10-00</b>	
General		1
<b>AIRCRAFT DAMAGE REPORTS</b>	<b>2-10-01</b>	
General		1
<b>CONDITION OF SOIL</b>	<b>2-10-02</b>	
General		1
<b>TERRAIN FEATURES</b>	<b>2-10-03</b>	
General		1
<b>ACCESS AND SITE PREPARATION</b>	<b>2-10-04</b>	
General		1
Manufactured and Prepared Surfaces		
<b>DAMAGE CONTROL AND SAFETY</b>	<b>2-20-00</b>	
General		1
<b>DAMAGE CONTROL</b>	<b>2-20-01</b>	
General		1
<b>SITE RECLAMATION</b>	<b>2-20-02</b>	
General		1
<b>PERSONNEL SAFETY</b>	<b>2-20-03</b>	
General		1
<b>WEIGHT AND C.G. MANAGEMENT</b>	<b>2-30-00</b>	
General		1
<b>WEIGHT MANAGEMENT</b>	<b>2-30-01</b>	
General		1
Determine Recoverable Empty Weight		3
Determine Net Recoverable Weight		3
Location of Center of Gravity in Percent of M.A.C.		6
Main Jack Point Load Determination		

**2-CONTENTS**

**Boeing Canada**  
de Havilland Division

**DASH 8 AIRCRAFT RECOVERY**

**TABLE OF CONTENTS (Cont'd)**

<b>Subject</b>	<b>Chapter Section Subject</b>	<b>Page</b>
<b>REMOVAL OF PAYLOAD</b>	<b>2-30-02</b>	
General		1
Cargo Compartment		
<b>REMOVABLE COMPONENTS</b>	<b>2-30-03</b>	
General		1
<b>DEFUELING</b>	<b>2-30-04</b>	
General		1
Description/Operation		
Safety Precautions		2
Defueling		
Manual Defueling		4
<b>POWER PLANT</b>	<b>2-30-05</b>	
General		1
Removal/Propellers		
Engines		

**2-CONTENTS**

## **DASH 8 AIRCRAFT RECOVERY**

### **SURVEY AND PREPARATION**

#### **1. General**

This chapter describes the preparatory planning and precautionary procedures required prior to lifting or moving the aircraft in order to preclude accidents, minimize further damage and to accelerate the recovery process.

Problems, such as an engine failure, a blown tire, or a brake malfunction should be handled with minimum amount of delay. If the aircraft is substantially damaged in a landing, take-off or taxiing accident, an investigation will be required. In these instances, the aircraft or its parts should not be moved until released by applicable transportation accident investigation safety board representative or equivalent. Accident investigation takes precedence over aircraft recovery. Its objective is to determine the cause of the accident, liability and extent of damage. Such investigation could be on going through out the recovery process.

#### **2. Advance Planning**

- A. The need for sound planning and preparation cannot be over emphasized, secondary damage caused during the recovery operation, sometimes is as great as the initial damage incurred. Security should be established at the site at the earliest possible time to minimize or reduce fire hazards, prevent theft, prevent the destruction of information needed for accident investigation, and control unauthorized personnel access to site. Advance planning is required to assure that the necessary equipment and skills will be furnished and can be quickly put to use when needed. Prepare a detailed Aircraft Recovery Plan ready to be put into motion as soon as an accident occurs or investigation allows. Consider the necessary emergency actions and assign specific responsibilities for carrying them out. The complexities and responsibilities involved in removing disabled aircraft make it imperative that someone be designated to take charge of the overall operation. A trained crew of specialists can expedite the recovery operation and successfully utilize the aid of untrained personnel who may be assigned to help. Inform all concerned of the preparations and capabilities as well as the policies regarding disabled aircraft removal.
- B. Local airline representatives should have a clear definition of their responsibility and authority to enter into contracts for removal services; and airport authorities should be made aware of these arrangements.
- C. Among other things, include in the plan:
  - (1) The type and location of heavy equipment or special units needed and the average time it will take to get cranes, etc., to the airport.
  - (2) Access routes to all parts of the airport and any special routes needed for cranes in the vicinity of overhead power lines.
  - (3) Grid maps should be available for use during aircraft recovery operations.

**2-00-00**

## DASH 8 AIRCRAFT RECOVERY

- (4) Manufacturers' data pertaining to aircraft recovery for the type of aircraft shall be readily available.
  - (5) The economic reasons to plan for the quick removal of disabled aircraft from airport operational areas in order to maintain uninterrupted flight operations.
- D. Make advance plans to obtain the services of aircraft removal equipment and crews, through agreements with other airport sponsors, with military airfields, or with aeronautical industries in the vicinity of civil airports. An inventory of locally available salvage equipment should be kept current. This would include, in addition to equipment located on the airport, any construction equipment located on the airport, that which construction contractors and other operators of heavy machinery have in the vicinity and agree to make available.
- When arranging for equipment, anticipate that a primary source of equipment or operators may not be available, and that a second or even a third source for these services must be considered in the plans. Mere plans to call for heavy equipment are insufficient. An operator must have arrangements with equipment companies, and a commitment from the company to provide the services when they are needed.
- E. It must be recognized that it will be necessary to deal with complex mechanical problems, especially regarding hull inspection, planning the operation, and in determining what method to use in lifting and removal operations. Plans to communicate with the necessary skilled technical personnel must be in place before hand.
  - F. The conditions of the aircraft must be determined, as most of the work associated with removal will be dependent upon these findings. Other major considerations include weather, terrain, and the type of special removal equipment (e.g., cranes and winches) available on the airport or through local rental companies and contractors.
  - G. Some of the more common situations that occur which result in an aircraft becoming disabled are outlined below, along with typical methods of removal.

### CONDITIONS

Collapsed nose gear.

### TYPICAL METHODS OF REMOVAL

Jacking and use of pneumatic lifting bags; hoisting with cranes and the use of specially designed slings; or by pulling down on tail tie-down fitting.

**2-00-00**



**Boeing Canada**  
de Havilland Division

**DASH 8 AIRCRAFT RECOVERY**

CONDITIONS

TYPICAL METHODS OF REMOVAL

Collapsed or retracted main gear,  
but nose gear intact and extended.  
Collapsed main gear, one side only.  
Collapse of all landing gears.  
One or more main gear off pavement,  
no aircraft damage.

Jacks, pneumatic lifting bags, or cranes.  
  
Jacks, pneumatic lifting bags, or cranes.  
Jacks, pneumatic lifting bags, and cranes.  
Assuming that the aircraft will have the  
gear bogged down in soft soil or mud,  
extra towing or winching equipment or use  
of pneumatic lifting bags will usually  
suffice for this type removal. It may  
be necessary to construct a temporary  
ramp from timbers, matting, etc.

Nose gear failure and one side  
or main gear failure.

Jacks, pneumatic lifting bags, or  
cranes.

Tire failures and/or damaged wheels.

Jacks and parts replacement.

(a) In addition to lifting an aircraft, plans are required for equipment to  
remove an aircraft whose gear cannot be lowered. Equipment which  
has been most frequently used for this purpose includes flatbed trail-  
ers and various types of dollies.

(b) Other equipment or systems, such as that offered by companies who  
specialize in this business are also available. While these companies  
employ special equipment for conveying an aircraft, they also com-  
plement conventional equipment, such as jacks or cranes.

H. Some of the most likely places to obtain support equipment needed for aircraft re-  
covery are:

Boatyards and shipyards  
Bus company garages  
Construction firms  
Crane rental companies  
Dock areas  
Foundries  
Junkyards  
Large farms  
Lumberyards

Machine shops  
Military establishments  
Oil company shops  
Quarries  
Railroad shops and yards  
Rigging companies  
Sugar Mills  
Telephone companies  
Trucking firms

(1) In investigation of recovery procedures, dollies, wooden and  
steel beams, towing equipment and procedures used by  
house moving contractors can be adapted for use in damaged  
aircraft recovery operations.

**2-00-00**

## **DASH 8 AIRCRAFT RECOVERY**

- (2) Field representatives of aviation insurance underwriting companies are in a position to furnish information regarding firms or individuals that are experienced in this work, assuming that insurance firms will be notified of such occurrences promptly.
- (3) It is necessary that arrangements be made to obtain fuel handling equipment, as aircraft with a portion or all of the gear off the runway will most likely require defueling prior to other operations.
- (4) Plans and arrangements will be required to obtain bulldozers, etc., for those exceptional cases where aircraft have broken up and are determined to be beyond salvage value. This involves emergency situations where secondary damage is not a limiting consideration. The plans may include methods for dragging an aircraft off a runway in an emergency situation by the use of cables and towing equipment.
- (5) The infrequent use of removal equipment, such as pneumatic lifting bags, presents special problems associated with storage, inventory, periodic inspection, and tests. Adequate maintenance and storage are essential to assure serviceability and availability of removal equipment.

**2-00-00**

PAGE 4

OCT 10/90

**Boeing Canada**  
de Havilland Division  
**DASH 8 AIRCRAFT RECOVERY**

**DAMAGE AND TERRAIN**

**1. General**

- A. The following sections cover the initial survey of damage, an initial examination of structural condition is made and its influence on the recovery are examined.
- B. The necessity for soil analysis for load bearing and tethering capability are described.
- C. Terrain features, access and site preparation are also covered.

**CAUTION: BEFORE PROCEEDING WITH THE DAMAGE SURVEY OR WITH ANY PRELIMINARY WORK ON AIRCRAFT THE FOLLOWING PRECAUTIONS SHOULD BE TAKEN.**

- A. FLUSH AIRCRAFT AND GROUND SURFACES THOROUGHLY OF ANY FLAMMABLE LIQUID SPILLS.
- B. DISCONNECT AND REMOVE AIRCRAFT BATTERIES.
- C. INSTALL GROUND LOCK DOWN PINS IN THE LANDING GEARS THAT ARE IN THE EXTENDED POSITION.
- D. GROUND AIRCRAFT TO A COPPER COATED STEEL ROD AND CABLE.
- E. DEPRESSURIZE HYDRAULIC SYSTEMS.
- F. REMOVE OXYGEN BOTTLES. REFER TO APPROPRIATE CHAPTERS IN MAINTENANCE MANUAL FOR ABOVE PROCEDURES.

**NOTE:** Remove the Voice and Flight Recorders (figure 1). The voice and flight recorders are located together in the aft fuselage. Access to recorders is through access panel 311AB on underside of aft fuselage.

**NOTE:** It may be necessary to clean the aircraft of ground residue before inspection for damage can be completed.

**2-10-00**

PAGE 1

OCT 10/90

DASH 8 AIRCRAFT RECOVERY

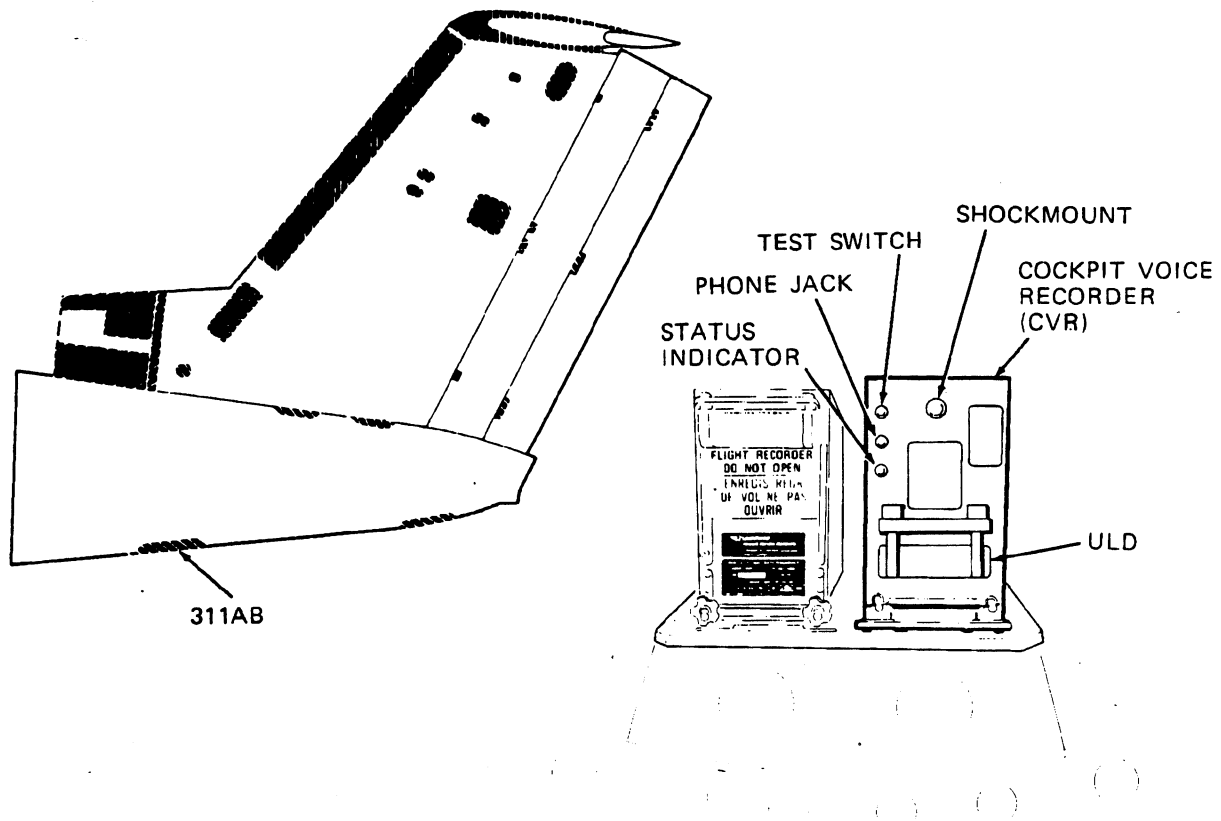

NOTE:  
ACCESS TO RECORDERS  
THROUGH ACCESS PANEL  
311AB UNDERSIDE OF  
REAR FUSELAGE

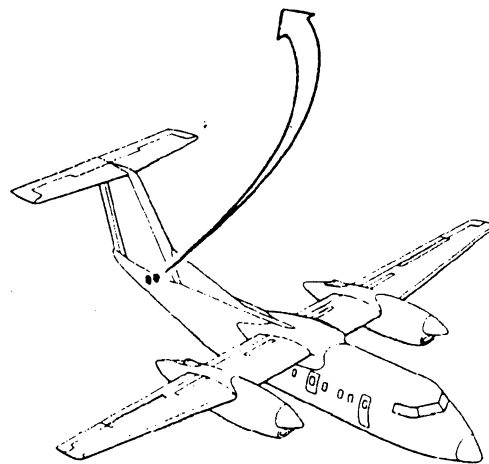

VOICE AND FLIGHT RECORDERS

FIGURE 1

2-10-00

**Boeing Canada**  
de Havilland Division  
**DASH 8 AIRCRAFT RECOVERY**

**AIRCRAFT DAMAGE REPORTS**

**1. General**

Determine the condition of the aircraft as early as possible. Be aware of other known damage as reported from other sources such as flight crew log sheets, insurance carrier's report and operator's incident report.

The preliminary report shall be followed by one or more detail reports providing a more explicit description of the damage and existing conditions. These reports guide repair activities and/or removal of the aircraft from the scene of the incident. Photographic coverage of damage shall be provided as soon as practical.

Oral communication is to be expected, and if equipment is available, should be recorded. Written reports are mandatory.

Determine how the impact of the accident may have affected the other structural members. Rivets, bolts or fasteners of any kind that are tipped, sheared or loose may serve as clues to damaged internal structure. Whenever buckling, cracks or elongation is observed, the structural member is considered to have failed and should not be depended upon to carry the load for which it was designed.

Since it is the intent to first try to tow the aircraft by the use of its landing gears, the gears as well as the supporting structures must be carefully inspected. Check the stabilizer strut, shock strut, drag strut frame assembly and also the yoke assembly. For purposes of towing the aircraft, the failed parts can temporarily be strengthened or reinforced by steel bars.

**2-10-01**

PAGE 1

OCT 10/90

**Boeing Canada**  
de Havilland Division  
**DASH 8 AIRCRAFT RECOVERY**

**THIS PAGE INTENTIONALLY LEFT BLANK**

**2-10-01**

**PAGE 2**

**OCT 10/90**

## **DASH 8 AIRCRAFT RECOVERY**

### **CONDITION OF SOIL**

#### **1. General (Figure 1)**

- A. In order to determine the proper method of recovery, the strength and condition of the soil around the aircraft and along the recovery path to a hard surface will need to be determined.

**WARNING: MAXIMUM ALLOWABLE TOWING FORCE IS 7052 LB. (3198.8 KG.) LIMIT PER MAIN GEAR.**

- B. The condition of the soil, the extent of structural damage to aircraft and weather conditions all have influence on the selection of the procedures that will be required to move the aircraft.
- C. Soil strength characteristics are required to determine the type of jacking, shoring, towing and ground anchor operations which will be used.
- D. The services of a civil engineer or soil analyst could be contracted to study the surface bearing ability of the local ground.
- E. Check the forecasted weather reports as it may affect the terrain.
1. Heavy rains may turn the soil to mud. Drainage ditches could be dug to remove excess water.
  2. Snow, ice, and high winds will adversely affect the recovery operation.

**2-10-02**

**Boeing Canada**  
de Havilland Division  
**DASH 8 AIRCRAFT RECOVERY**

APPROX. CBR RANGE*	SURFACE MATERIAL	SHORING (CRIBBING) REQUIRED FOR ROLLING LOAD				SHORING (CRIBBING) REQUIRED FOR JACKING LOADS			
		MAXIMUM ALLOWABLE CONTACT PRESSURE		MINIMUM CONTACT AREA REQUIRED PER		MAXIMUM ALLOWABLE CONTACT PRESSURE		MINIMUM CONTACT AREA REQUIRED PER	
		PSI	KG/CM <sup>2</sup>	2,000 LBS (IN <sup>2</sup> )	1,000 KG (CM <sup>2</sup> )	PSI	KG/CM <sup>2</sup>	150,000 LBS (FT <sup>2</sup> )	70,000 KG (M <sup>2</sup> )
2 - 6	SOFT WET CLAY OR WET ORGANIC SOIL	18	1.25	1,100	8,000	8	.55	130	12.7
8 - 20	LOOSE SAND OR SANDY SOIL	65	4.5	300	2,200	35	2.4	30	3.0
15 - 30	SAND WITH CLAY	100	6.9	200	1,450	50	3.5	21	2.0
20 - 60	WELL GRADED SAND & MEDIUM CLAY	180	12.4	110	800	85	5.9	12.5	1.2
20 - 60	SANDY GRAVEL OR CLAYEY GRAVEL OR DRY CLAY	300	20.7	65	480	165	11.4	6.3	.6
50 AND ABOVE	COMPACTED SANDY CLAYEY GRAVELS	N/A	N/A	N/A	N/A	200	13.8	5.2	.5

\* CBR DATA IS GIVEN FOR REFERENCE ONLY. THE LOADING-CARRYING CAPABILITY OF SURFACE SOIL CAN BE STATED IN TERMS OF CBR, BUT A WET MATERIAL HAVING A CBR OF 4 OR 5 CAN BE, OR EQUAL, BEARING STRENGTH TO A CBR 40 OR 50 MATERIAL, WHEN DRY.

**SOIL SURFACE CONDITIONS FOR SHORING (CRIBBING) REQUIREMENTS**  
**FIGURE 1**

**2-10-02**



## **DASH 8 AIRCRAFT RECOVERY**

### **TERRAIN FEATURES**

#### **1. General**

The firmness, condition and the slope of the terrain around the aircraft accident site, the extent of damage to aircraft and the weather conditions are major factors to be considered in determining the most practical method of lifting and moving the aircraft. In addition to the physical features it should be determined whether the site and access roads are on private or public property. Arrangements should be made to survey the site and access roads as part of the legal requirements. Photographs should be taken before and after the recovery process as a part of the planning function and for records. Towing or winching operations will require the grading of high and low spots to smooth out the path of the aircraft and tow vehicles.

Observe surface hardness, smoothness and drainage for possible effect of rainfall on the load carrying capability of the ground. Determine the safe bearing load and surface area of the ground, soil strength should have the same CALIFORNIA BEARING RATING (C.B.R.) for a depth of 8 inches (20.35 cm). The force to tow an aircraft increases as a function because of the softness of the ground. Rain and snow can further complicate the recovery operation, irrigation pumps will be required or drainage ditches dug to divert standing water.

If the jacking points are buried, it will be necessary to dig down to hard ground to expose enough hard surface area for cribbing.

**2-10-03**

PAGE 1

OCT 10/90

**Boeing Canada**  
de Havilland Division  
**DASH 8 AIRCRAFT RECOVERY**

**THIS PAGE INTENTIONALLY LEFT BLANK**

**2-10-03**

PAGE 2

OCT 10/90

## **DASH 8 AIRCRAFT RECOVERY**

### **ACCESS AND SITE PREPARATION**

#### **1. General**

It is advantageous to start defueling operations as soon as possible after passenger evacuation. It should save time and should expedite defueling and unloading operations if consideration is given to maintaining material, such as fiber glass matting, the various available types of airfield landing mat, or other ramp construction materials to make a temporary vehicle roadway to the aircraft. Consider using material that can be reused, rather than constructing a temporary roadway which can prove to be costly. Planning for a single means of access to the aircraft and to bring the aircraft out has obvious advantages.

Depending on the local conditions, steps should be taken to clear shrubs and trees; remove fences; fill ditches; level the immediate site area and prepare access roads.

#### **2. Manufactured and Prepared Surfaces (Figure 1)**

- A. Sometimes, it will be necessary to prepare a path from the aircraft to the runway. A ramp or treadway over soft ground will facilitate the towing of the aircraft. Several methods are available for stabilizing the surface.
- B. Drain or evacuate any standing water. Pour gravel or crushed rock in the affected area and pack down. Use power tamper to obtain sufficient bearing strength. Some soft mud should be displaced with this action. Next, steel matting, railroad ties, plywood, steel plate or any of these combinations may be laid over the compacted gravel.
- C. Most railroad ties available are usually reclaimed and are uneven when laid cross-wise to the path. Heavy timbers may be used in lieu of railroad ties. Steel plate or plywood will smooth out the rough surfaces. Plywood, when laid in layers, must be arranged so that the joints are staggered.

**2-10-04**

Boeing Canada  
de Havilland Division  
**DASH 8 AIRCRAFT RECOVERY**

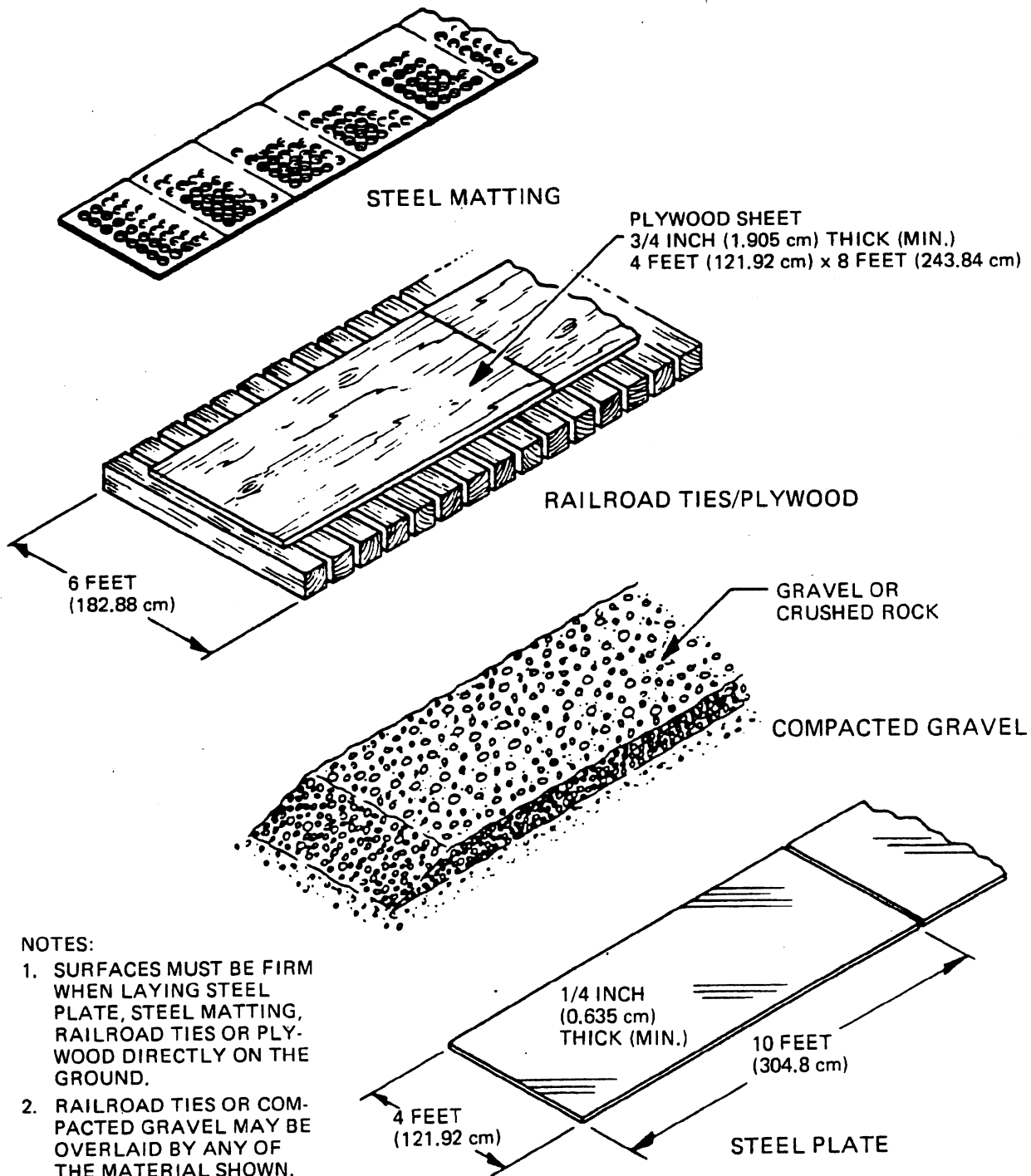

**NOTES:**

1. SURFACES MUST BE FIRM WHEN LAYING STEEL PLATE, STEEL MATTING, RAILROAD TIES OR PLYWOOD DIRECTLY ON THE GROUND.
2. RAILROAD TIES OR COMPACTED GRAVEL MAY BE OVERLAID BY ANY OF THE MATERIAL SHOWN.

**TYPICAL PREPARED SURFACES**

**FIGURE 1**

**2-10-04**

## **DASH 8 AIRCRAFT RECOVERY**

### **DAMAGE CONTROL AND SAFETY**

#### **1. General**

To prevent additional aircraft damage or personnel injury while following recovery techniques and/or procedures observe the following:

**CAUTION: IF WEATHER FORECAST IS FOR HIGH WIND CONDITIONS, PREPARATION FOR TETHERING AIRCRAFT MUST BE PLANNED.**

**DO NOT ATTEMPT TO JACK OR MOVE THE AIRCRAFT IN WIND CONDITIONS ABOVE 20 M.P.H. (32 KM/HR).**

**IN SOME LOCATIONS AIRBORNE DUST AND SAND MAY REQUIRE THE RECOVERY TEAM TO USE FACE MASKS AND EYE PROTECTION.**

**2-20-00**

PAGE 1

OCT 10/90

**Boeing Canada**  
de Havilland Division  
**DASH 8 AIRCRAFT RECOVERY**

**THIS PAGE INTENTIONALLY LEFT BLANK**

**2-20-00**

**PAGE 2**

**OCT 10/90**

**Boeing Canada**  
de Havilland Division  
**DASH 8 AIRCRAFT RECOVERY**

**DAMAGE CONTROL**

**1. General**

If site of incident and extent of damage prevent immediate movement of aircraft to a location where it can remain for an extended period of time, proceed with the following.

**NOTE: The aircraft attitude, damage or location may prevent completion of all items. The requirement is to secure the aircraft as much as possible to prevent further damage.**

- A. To secure aircraft against addition damage (figure 1).
1. Ensure nose and main landing gear ground lock pin are installed where possible.
  2. Install wheel chocks and secure with sandbags where possible.
  3. Install nose and main gear mooring lines where possible.
  4. Install nose and wing jacks, extend so that they are snug at jacking points without lifting the aircraft, install railway ties, plywood panels or steel plates beneath jacks to prevent sinking.
  5. If nose gear is collapsed and tail is elevated, brace nose section with sandbags on each side, secure tail section with a mooring line attached to ground anchors. Follow a similar procedure if possible to secure a wing tip if a main landing gear has collapsed.
  6. Ensure aircraft batteries are removed.
  7. Remove baggage and cargo.
  8. Install propeller restraints and install engine and other protective covers.
  9. Close all doors, emergency exits, escape hatches and access panels.

**2-20-01**

PAGE 1

OCT 10/90

## DASH 8 AIRCRAFT RECOVERY

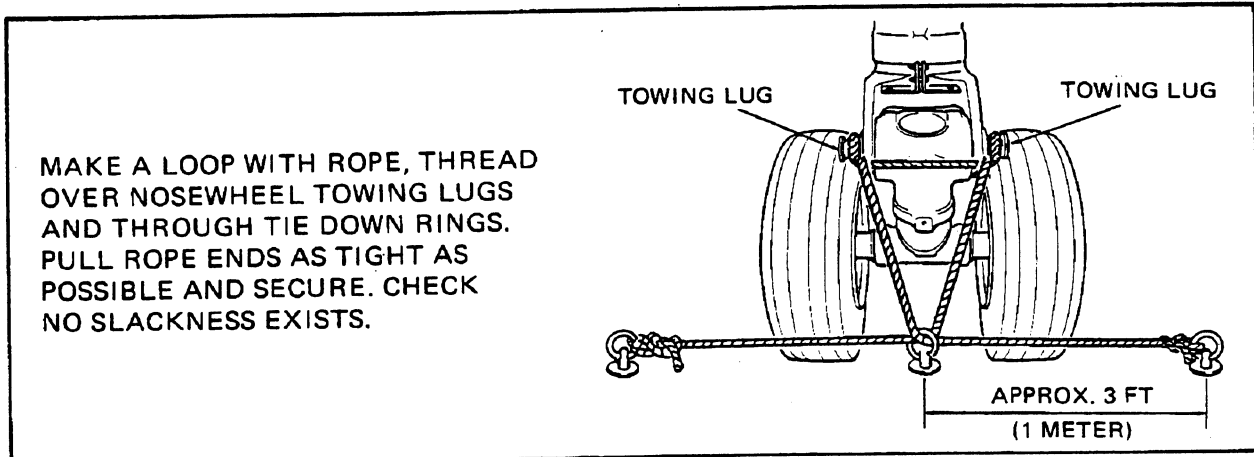

### NOSE GEAR TIE-DOWN

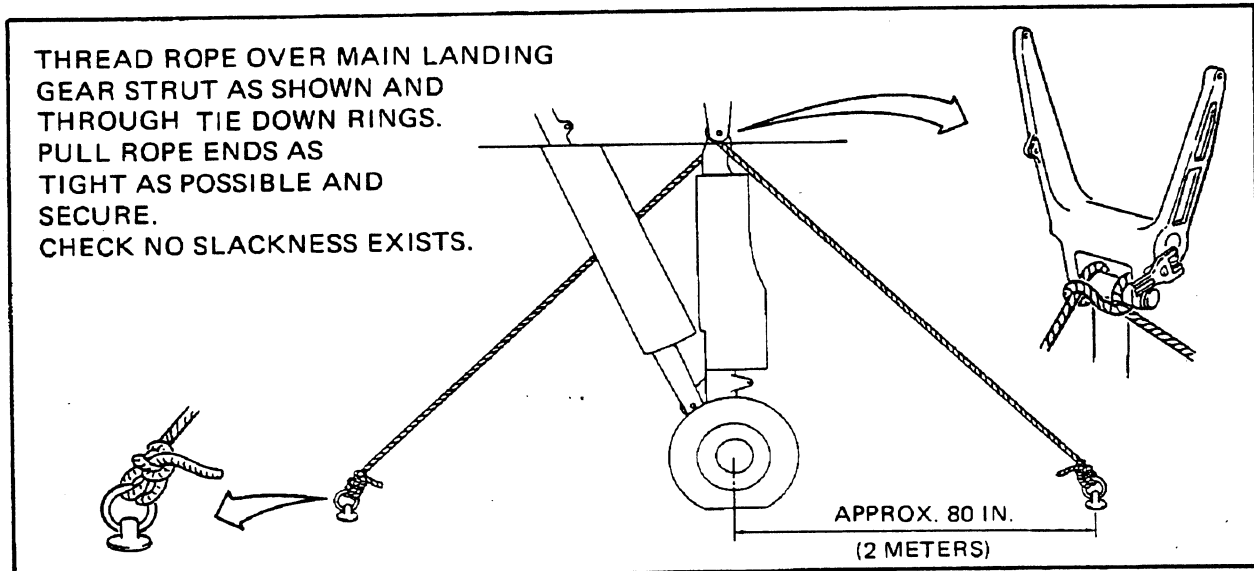

### MAIN GEAR TIE-DOWN

IF AIRCRAFT IS TO BE PARKED FOR AN EXTENDED PERIOD OF TIME IN EXTREME HIGH WIND CONDITIONS, TIE DOWN LINES MAY BE SAFELY ATTACHED AT THE FOLLOWING THREE POINTS:

- NOSE GEAR LEG AT TOWING LUGS.
- BOTH MAIN GEAR LEGS.

NOTE: SUITABLE WHEEL CHOCKS MUST BE PLACED IN FRONT OF AND BEHIND MAIN WHEELS WHEN AIRCRAFT IS TIED DOWN.

NYLON OR POLYPROPYLENE ROPES 0.75 INCH (19mm) IN DIAMETER ARE RECOMMENDED.

### AIRCRAFT TIE-DOWN ARRANGEMENTS

FIGURE 1

# 2-20-01



DASH 8 AIRCRAFT RECOVERY

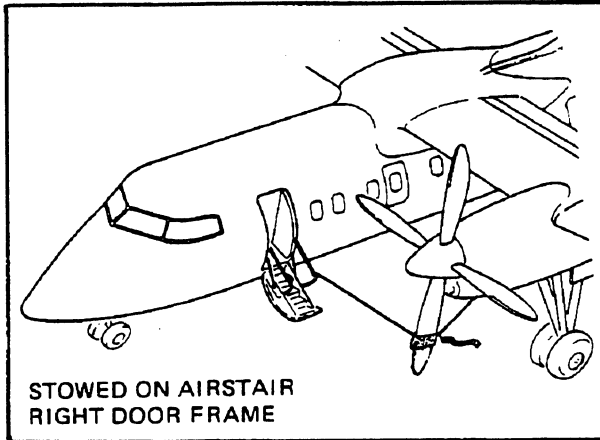

PROPELLER RESTRAINT –  
PASSENGER SAFETY

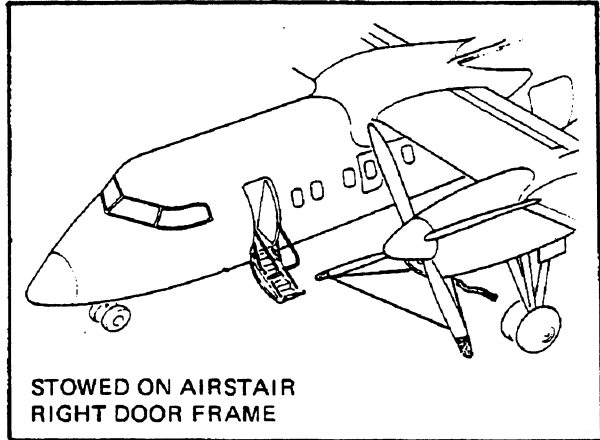

PROPELLER RESTRAINT –  
PARKING

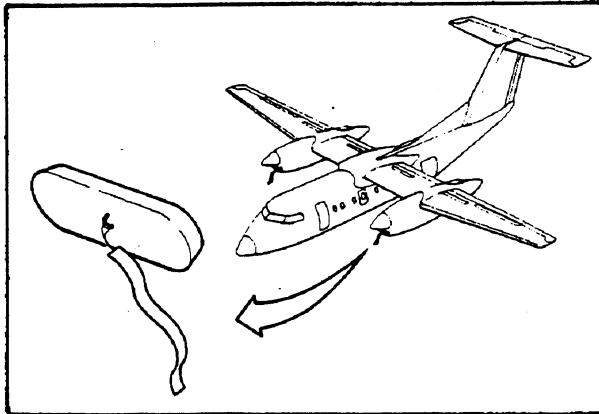

ENGINE AIR INTAKE

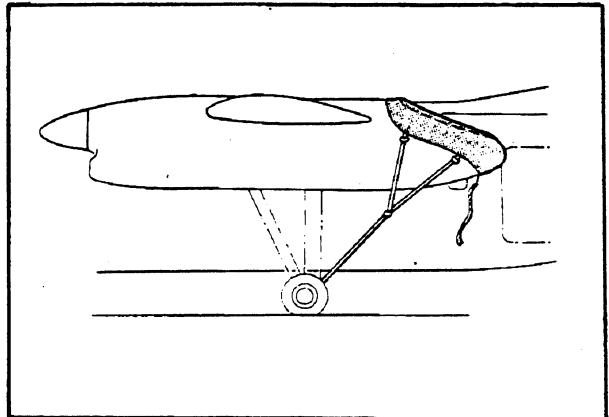

ENGINE EXHAUST

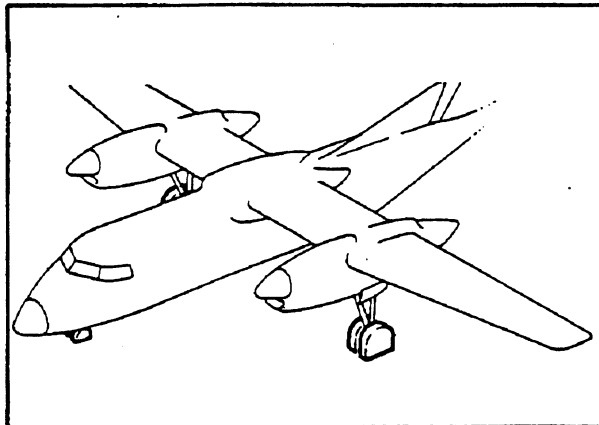

NOSE AND MAIN WHEELS

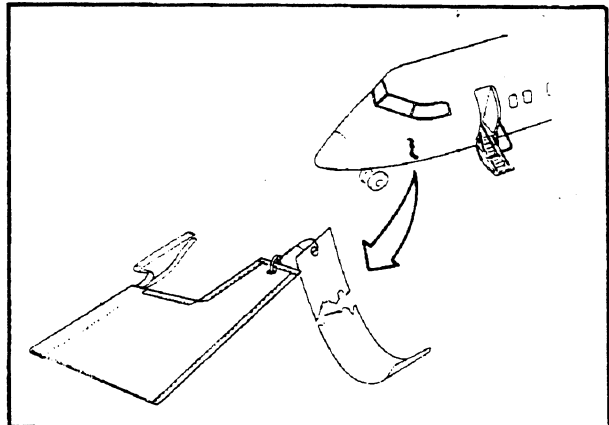

PITOT HEADS

AIRCRAFT COVERS AND RESTRAINTS

FIGURE 2

2-20-01

**Boeing Canada**  
de Havilland Division  
**DASH 8 AIRCRAFT RECOVERY**

**THIS PAGE INTENTIONALLY LEFT BLANK**

**2-20-01**

**PAGE 4**

**OCT 10/90**

## **DASH 8 AIRCRAFT RECOVERY**

### **SITE RECLAMATION**

#### **1. General**

The site area shall be cleaned up after aircraft removal operations are completed.

The damaged terrain at the site and along any temporary roadways shall be restored to near original conditions. All debris, equipment, and materials shall be removed.

Prior to reopening an operational area, make a safety inspection to determine that no hazardous pavement or shoulder conditions exist and that facilities, such as lighting are operational.

**2-20-02**

PAGE 1

OCT 10/90

**Boeing Canada**  
de Havilland Division

**DASH 8 AIRCRAFT RECOVERY**

**THIS PAGE INTENTIONALLY LEFT BLANK**

**2-20-02**

**PAGE 2**

**OCT 10/90**

**Boeing Canada**  
de Havilland Division  
**DASH 8 AIRCRAFT RECOVERY**

**PERSONNEL SAFETY**

**1. General (Figure 1)**

Steps must be taken to ensure the safety of personnel at the incident site. Depending on the extent of the damage the working conditions and the length of time that workers will be on the site the following should be considered:

- (1) Provide standby aircraft fire fighting and rescue vehicles.
- (2) Take measures to eliminate or reduce the hazards of spilled fuel by use of blanketing type fire extinguishing agents or by flushing with water.
- (3) Shore or support the aircraft to prevent inadvertent movements. Clear the area of unnecessary personnel during actual lifting or other movement.
- (4) Provide first aid kits and medical support.
- (5) Provide fire extinguishers on the site.
- (6) Arrange site security and communication with police to restrict unauthorized access.
- (7) Establish "No Smoking" perimeter.
- (8) Provide shelter and eating facilities.
- (9) Provide tools and equipment suited to the job.
- (10) Provide flood lights for any night time recovery work.

**2-20-03**

PAGE 1

OCT 10/90

**Boeing Canada**  
de Havilland Division  
**DASH 8 AIRCRAFT RECOVERY**

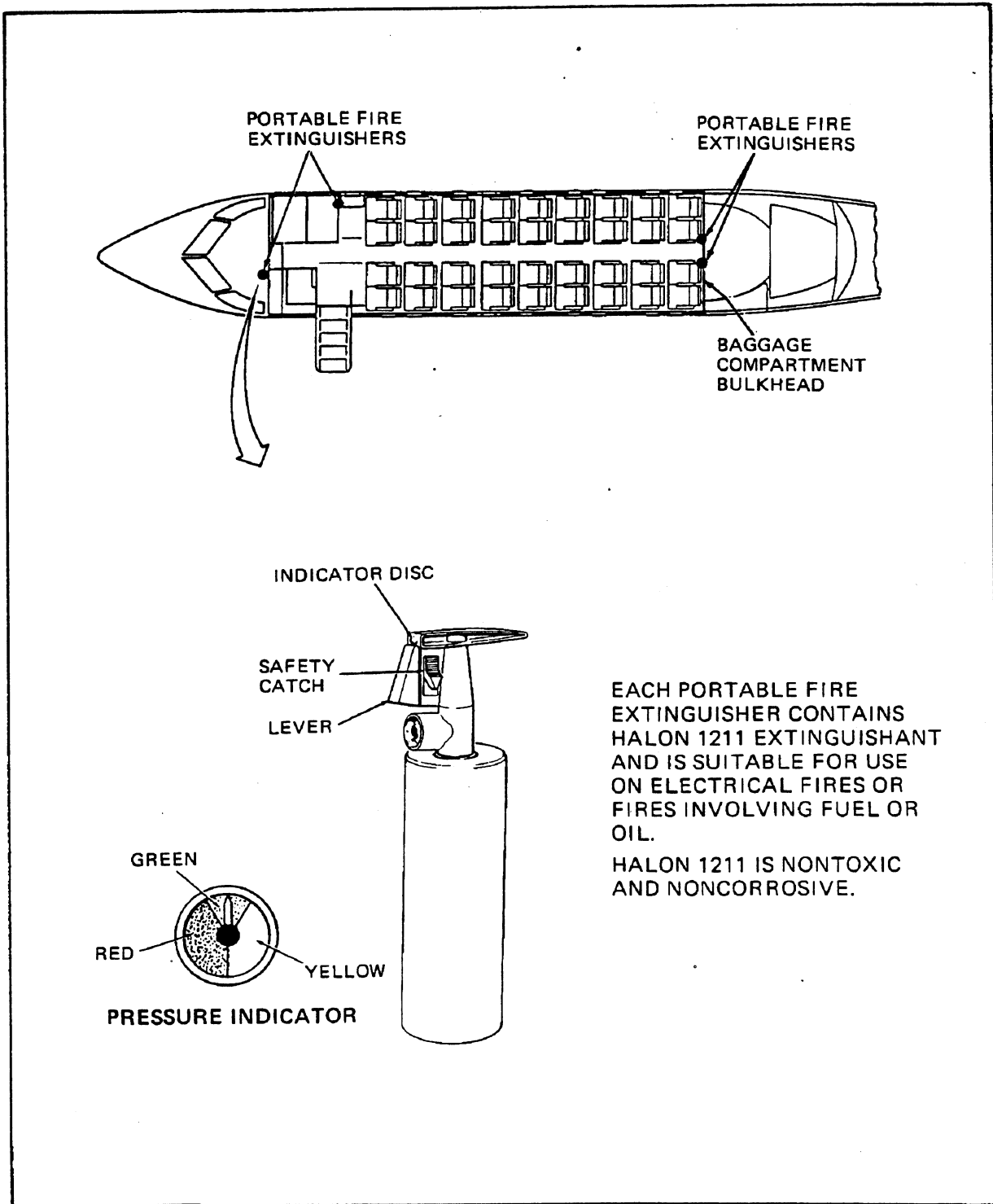

**PORTABLE FIRE EXTINGUISHERS**  
**FIGURE 1**

**2-20-03**

**Boeing Canada  
de Havilland Division**

# DASH 8 AIRCRAFT RECOVERY

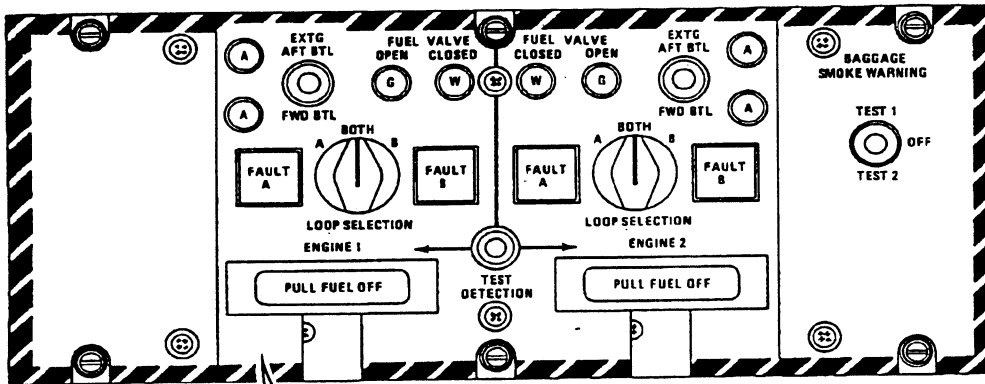
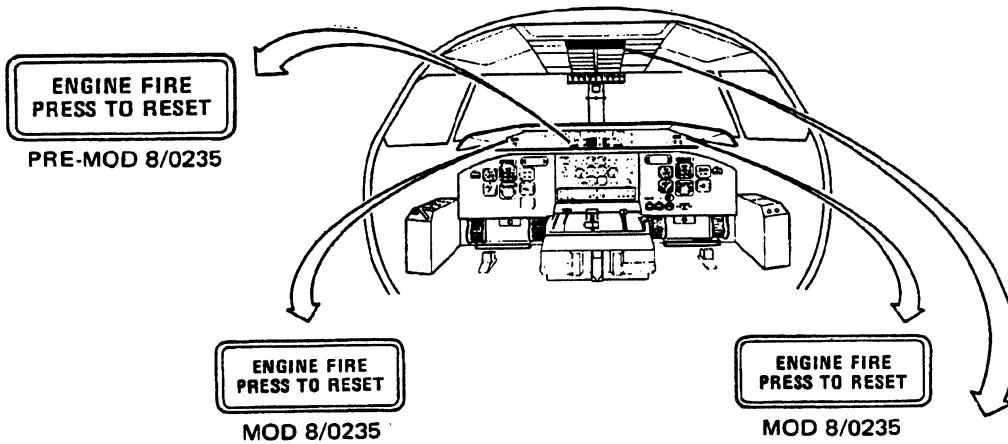

**FIRE PROTECTION PANEL**

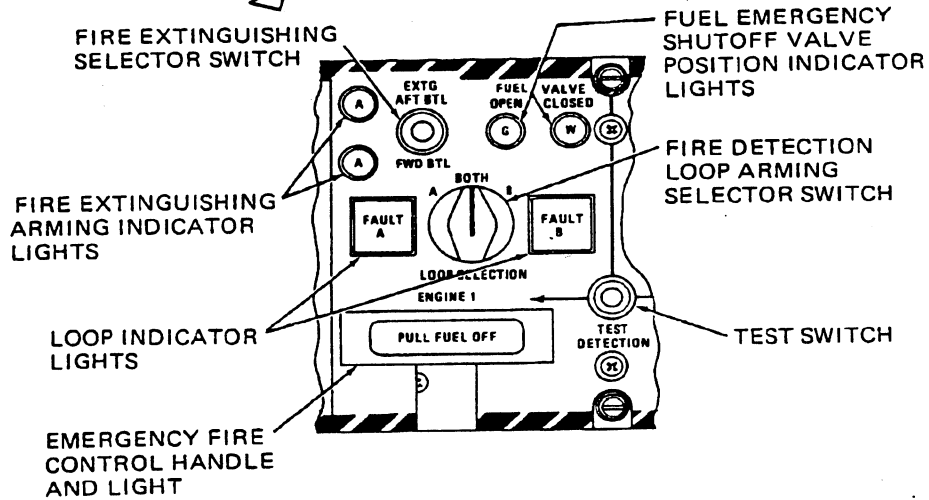

**FIRE PROTECTION PANEL AND MASTER FIRE WARNING LIGHT  
FIGURE 2**

**2-20-03**

**Boeing Canada**  
de Havilland Division  
**DASH 8 AIRCRAFT RECOVERY**

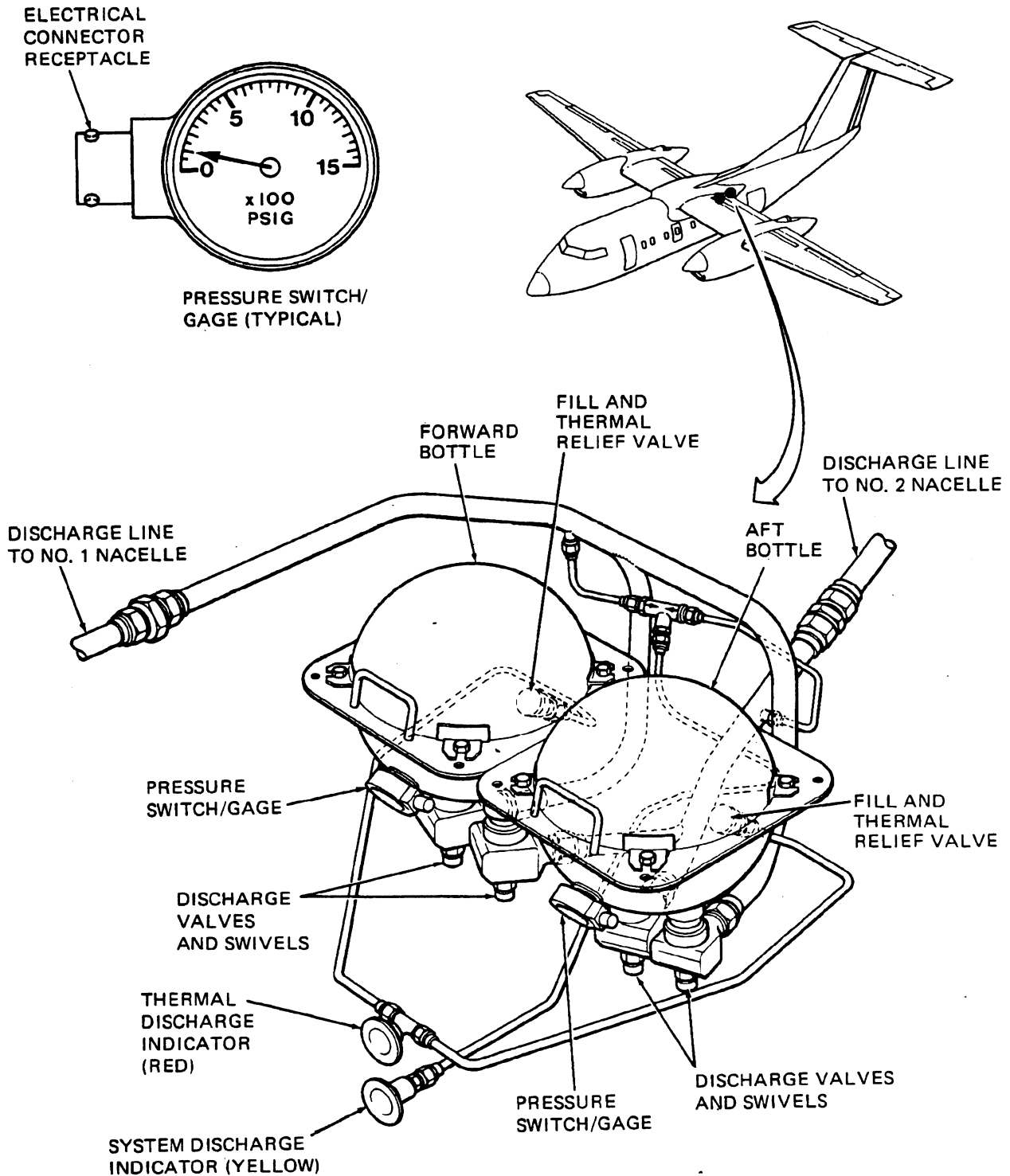

**FIRE EXTINGUISHING DISTRIBUTION**  
**FIGURE 3**

**2-20-03**



**Boeing Canada**  
de Havilland Division  
**DASH 8 AIRCRAFT RECOVERY**

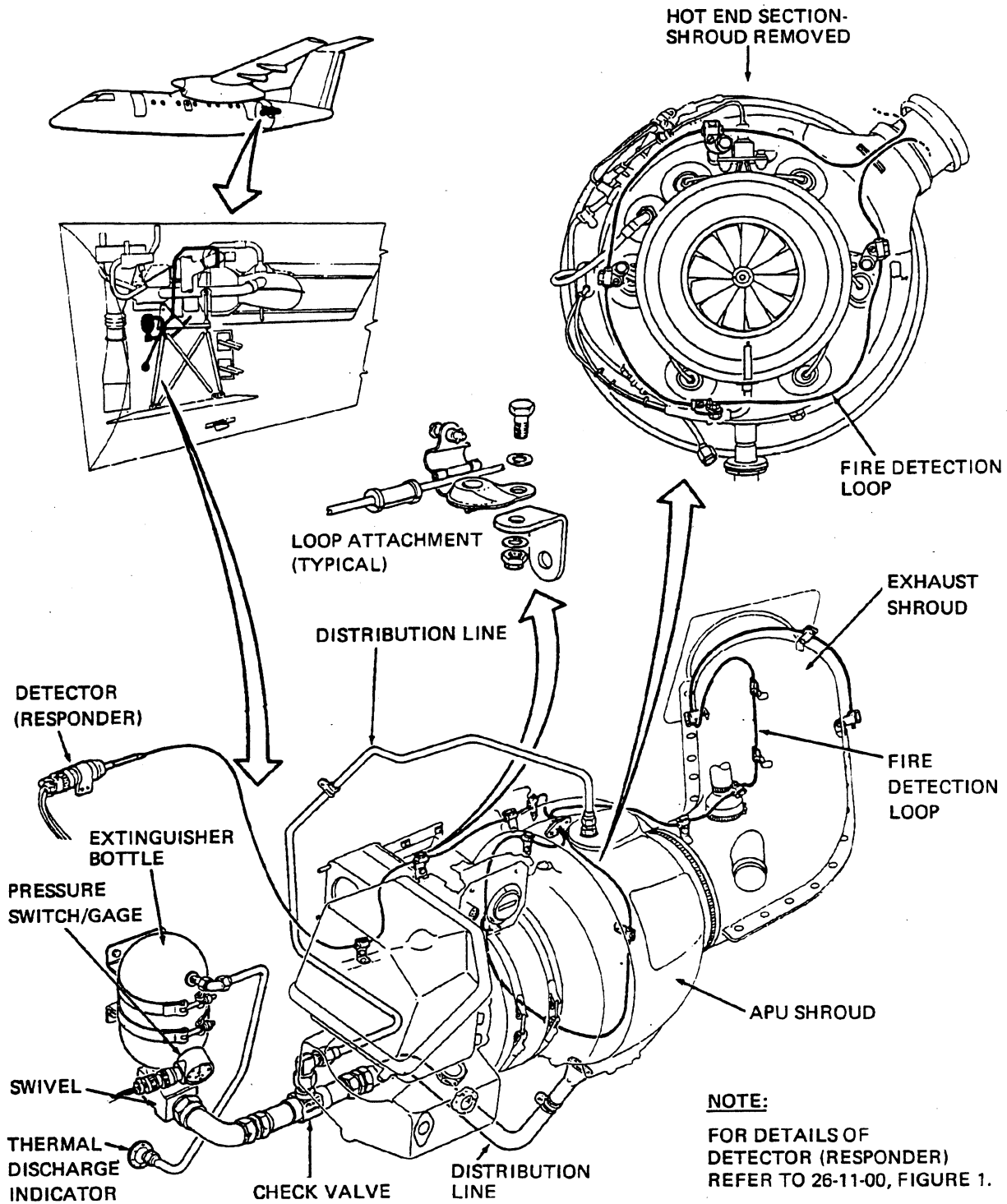

**APU FIRE PROTECTION SYSTEM - COMPONENT LOCATION**  
**FIGURE 4**

**2-20-03**

**Boeing Canada**  
de Havilland Division  
**DASH 8 AIRCRAFT RECOVERY**

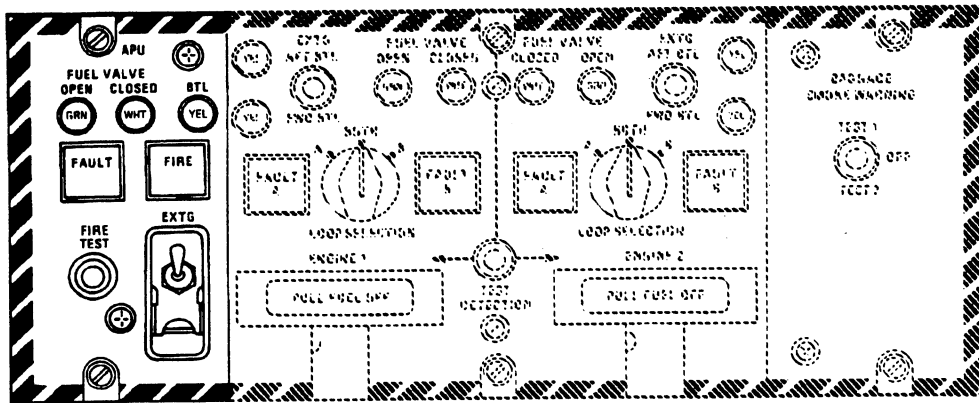
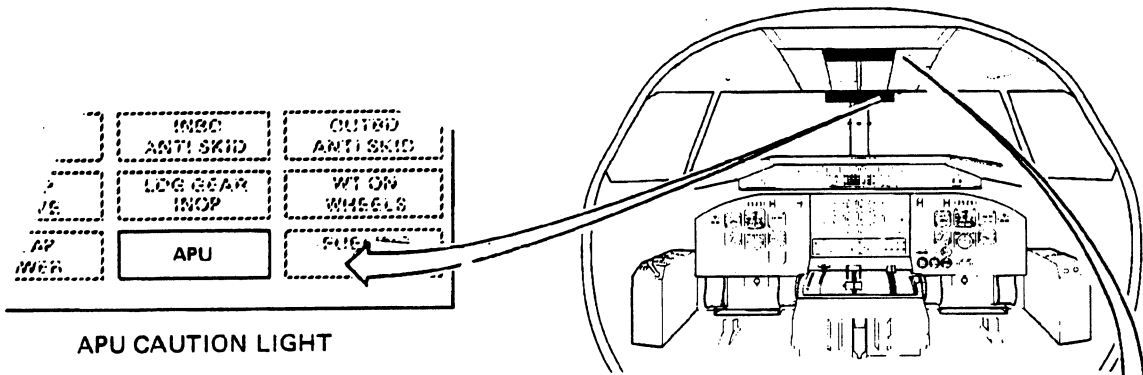

**FIRE PROTECTION PANEL**

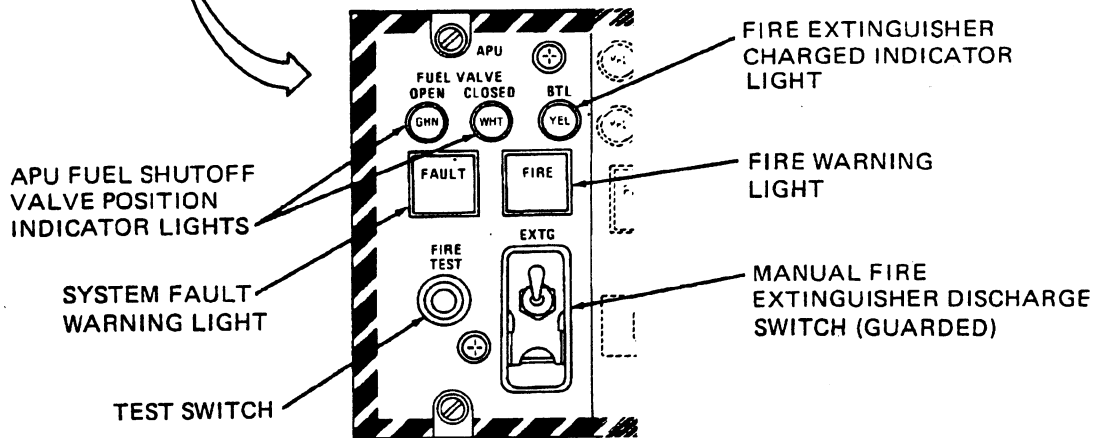

**APU FIRE PROTECTION PANEL**  
**FIGURE 5**

**2-20-03**

## **DASH 8 AIRCRAFT RECOVERY**

### **WEIGHT AND C.G. MANAGEMENT**

#### **1. General**

An accurate determination of the aircraft configuration is essential for the recovery operation. Every effort should be made to reduce total weight of aircraft to the minimum possible by removal of fuel, cargo, water and major components. This information is required to determine the type and capacity of equipment for lifting and towing such as aircraft jacks, cranes, cribbing base area and lift cable size.

**2-30-00**

PAGE 1

OCT 10/90

**Boeing Canada**  
de Havilland Division  
**DASH 8 AIRCRAFT RECOVERY**

**THIS PAGE INTENTIONALLY LEFT BLANK**

**2-30-00**

**PAGE 2**

**OCT 10/90**

**Boeing Canada**  
de Havilland Division  
**DASH 8 AIRCRAFT RECOVERY**

**WEIGHT MANAGEMENT**

**1. General**

Weight reduction of the aircraft is necessary prior to aircraft recovery. The amount of weight removed will reflect on the ease of lifting and towing aircraft. Payload such as passengers, passenger luggage and cargo, a plus aircraft components like damaged power plants, fuel and others, will significantly affect the final weight of the aircraft when removed. The technique of adding or transferring weight to one side of the aircraft is practiced for the purpose of shifting the C.G., enabling the opposite side to be lifted easily.

**2. Determine Recoverable Empty Weight (R.E.W.) (Figure 1)**

A. With flight crew, cabin attendant and passengers having vacated the aircraft, remove galley supplies (i.e. all O.W.E. items), passenger baggage and cargo, defuel aircraft.

**NOTE:** On completion of defueling, the aircraft fuel tanks and system will contain a certain amount of unrecoverable fuel.

B. Determine the Basic Weight (B.W.) and Center of Gravity Station (C.G. Sta.) consult the Weight and Balance manual and its supplement or the aircraft manifest to obtain this weight.

C. Enter Basic Weight and C.G. Sta in ① of figure 1 work sheet.

D. Subtract from the basic weight, items removed or lost during the aircraft accident, and subsequent to recovery operations using worksheet include items in ② such as aircraft components, cabin equipment, etc. the result is Recoverable Empty Weight (R.E.W.).

E. Calculate the moments by multiplying weight times C.G. Sta. and divide by 1000 for each item and enter the data on worksheet.

F. The C.G. Sta. for the Recoverable Aircraft can be determined as follows:

$$\text{C.G. Sta.} = \frac{\text{BASIC WT. } \textcircled{1} \times \text{C.G. Sta. } \textcircled{1} - \text{SUM OF } \textcircled{2} \text{ MOMENTS}}{\text{R.E.W.}}$$

Enter the R.E.W. and C.G. Sta. on worksheet in ③.

**2-30-01**

**Boeing Canada**  
de Havilland Division  
**DASH 8 AIRCRAFT RECOVERY**

ITEM	SUBJECT	WEIGHT 1000	C.G. STA (INCHES)	MOMENTS (KIP-IN.)
①	BASIC WEIGHT			
②	LESS ITEMS REMOVED DURING RECOVERY			
	SUBTOTAL FOR ② ITEMS			
③	RECOVERABLE EMPTY WEIGHT (REW)			

REW WORKSHEET  
FIGURE 1

**2-30-01**

## DASH 8 AIRCRAFT RECOVERY

### 3. Determine Net Recoverable Weight (N.R.W.) (Figure 2)

- A. Enter in ① the Recoverable Empty Weight (R.E.W.), C.G. Sta. and Moment obtained in paragraph 2F.
- B. Figure 3 shows moments corrections in the event that landing gears are retracted or flaps are fully extended during the recovery operation. Enter moment corrections as applicable in items ② and ③ of worksheet (figure 2).
- C. Weight and C.G. of residual fuel—determine the quantity of fuel in each tank after defueling. From the Weight and Balance obtain the C.G. of Fuel (408.2) in each tank. Values shown in Weight and Balance manual are for aircraft in level position. Enter this data as applicable in ④.

**NOTE:** The Weight of oil in the engines and in closed systems has been included in the R.E.W. any engine oil loss will have no significant effect on the aircraft C.G. and may be disregarded.

- D. Sum up the weights and moments (algebraically) and enter in item ⑤.
- E. The C.G. station for the Net Recoverable Weight (N.R.W.) of aircraft may be determined as follows:

$$\text{C.G. Station} = \frac{\text{SUM OF ⑤ MOMENTS}}{\text{N.R.W.}}$$

- F. Enter the C.G. station on worksheet item ⑥ (Figure 2).
- G. Use N.R.W. and C.G. station shown to determine Jacking Loads per figure 4.

**Boeing Canada**  
de Havilland Division  
**DASH 8 AIRCRAFT RECOVERY**

ITEM	SUBJECT	WEIGHT 1000	C.G. STA (INCHES)	MOMENTS (KIP-IN.)
①	RECOVERABLE EMPTY WEIGHT (REW)			
②	LANDING GEAR			
③	FLAPS			
④	RESIDUAL FUEL			
⑤	OTHER FLUIDS			
⑥	NET RECOVERABLE WEIGHT (NRW)			

NRW WORKSHEET  
FIGURE 2

**2-30-01**

PAGE 4

OCT 10/90



**Boeing Canada**  
de Havilland Division  
**DASH 8 AIRCRAFT RECOVERY**

ITEM	MOMENT <sup>3</sup> (LB.-IN. X 10 <sub>3</sub> )
NOSE GEAR (NG) MAIN LANDING GEAR (MLG)	
TOTAL ALL GEARS <sup>1</sup>	
FLAPS AND SLATS	
T.E. INBOARD	
T.E. OUTBOARD	
L.E. SLATS	
TOTAL ALL FLAPS <sup>2</sup>	

NOTE: DO NOT USE THESE FIGURES IF LANDING GEARS ARE IN THE DOWN POSITION OR FLAPS ARE IN FULL UP POSITION FOR RECOVERY.

<sup>1</sup> GEARS FROM FULL DOWN TO FULL UP

<sup>2</sup> FLAPS FROM FULL UP TO FULL DOWN

<sup>3</sup> (+) C.G. MOVED AFT  
(-) C.G. MOVED FORWARD

**MOMENT CORRECTIONS FOR GEARS AND FLAPS POSITIONS**  
**FIGURE 3**

**2-30-01**

PAGE 5

OCT 10/90

**Boeing Canada**  
de Havilland Division  
**DASH 8 AIRCRAFT RECOVERY**

**4. Location of Center of Gravity (C.G.) in Percent of M.A.C.**

The location of the C.G. in relation to the Mean Aerodynamic Chord (M.A.C.) may be calculated as follows:

To convert C.G. ARM in Inches to C.G. % M.A.C:

$$\% \text{ M.A.C.} = \frac{(\text{ARM} - 377.41)}{87.00} \times 100$$

To convert C.G. % M.A.C. to C.G. ARM in Inches:

$$\text{ARM (INCHES)} = \frac{87.00 \times \% \text{ M.A.C.}}{100} + 377.41$$

WHERE: PERCENT M.A.C. = Location of C.G. in percent of the M.A.C.  
 C.G. STATION = Station location of C.G. (inches)  
 87.00 = Width of M.A.C. (inches)  
 377.41 = Distance of M.A.C. leading edge to Station 'O' (inches)

**5. Main Jack Point Load Determination (Figure 4)**

- A. From previously calculated Net Recoverable Weight (N.R.W.) and C.G. Location the reactions in the primary Jack Points A, B and C can be determined from the chart shown in figure 4.
- B. The chart can be used also for determining jack loads in any aircraft attitude at rest when one of the landing gear has collapsed.
- C. Some criteria for using the chart are:

(1) Left main jack load at Point B are shown. These loads are higher than the right main jack load at Point C.

(2) The right main jack Point C load can be calculated as follows:

$$\text{POINT C LOAD} = \text{N.R.W.} - \text{POINT B LOAD} - \text{POINT A LOAD}$$

(3) Aircraft Jack Point Location are as follows (Figure 4 Sheet 2):

a)	FWD. FUSELAGE	X181.3	Y10.84	Z82.00
	L/H WING	X427.574	Y96.12	Z175.592
	R/H WING	X427.574	Y96.12	Z175.592

**2-30-01**

**Boeing Canada**  
de Havilland Division  
**DASH 8 AIRCRAFT RECOVERY**

D. To illustrate the use of the chart, an example is given as shown

GIVEN: AIRCRAFT N.R.W. = 28500 LB (12927.6 KG.)  
C.G. at STATION = 399.00 INCHES.  
AIRCRAFT IN HORIZONTAL ATTITUDE  
DETERMINE: JACK POINT C LOAD.

(1) First determine left wing jack load at Pt. B enter the chart from the bottom at 28500 lb (12927.6 Kg.) N.R.W. move up vertically until it intersects the Station 399.00 C.G. line. Identify as Point X. By tracing this point along a line to the right hand scale, the forward Body Jack Load is found to be 3300 lb (1496.88 Kg.) from point X, trace this point to the top scale and read 12800 lb (5806.08 Kg.) for Point B Left Wing Jack Load.

(2) The right main jack load at Point C can now be calculated, thus:

$$\begin{aligned}\text{POINT C LOAD} &= 28500 - 12800 - 3300 \\ &= 12400 \text{ LB (5624.64 Kg.)}\end{aligned}$$

**2-30-01**

PAGE 7

OCT 10/90

DASH 8 AIRCRAFT RECOVERY

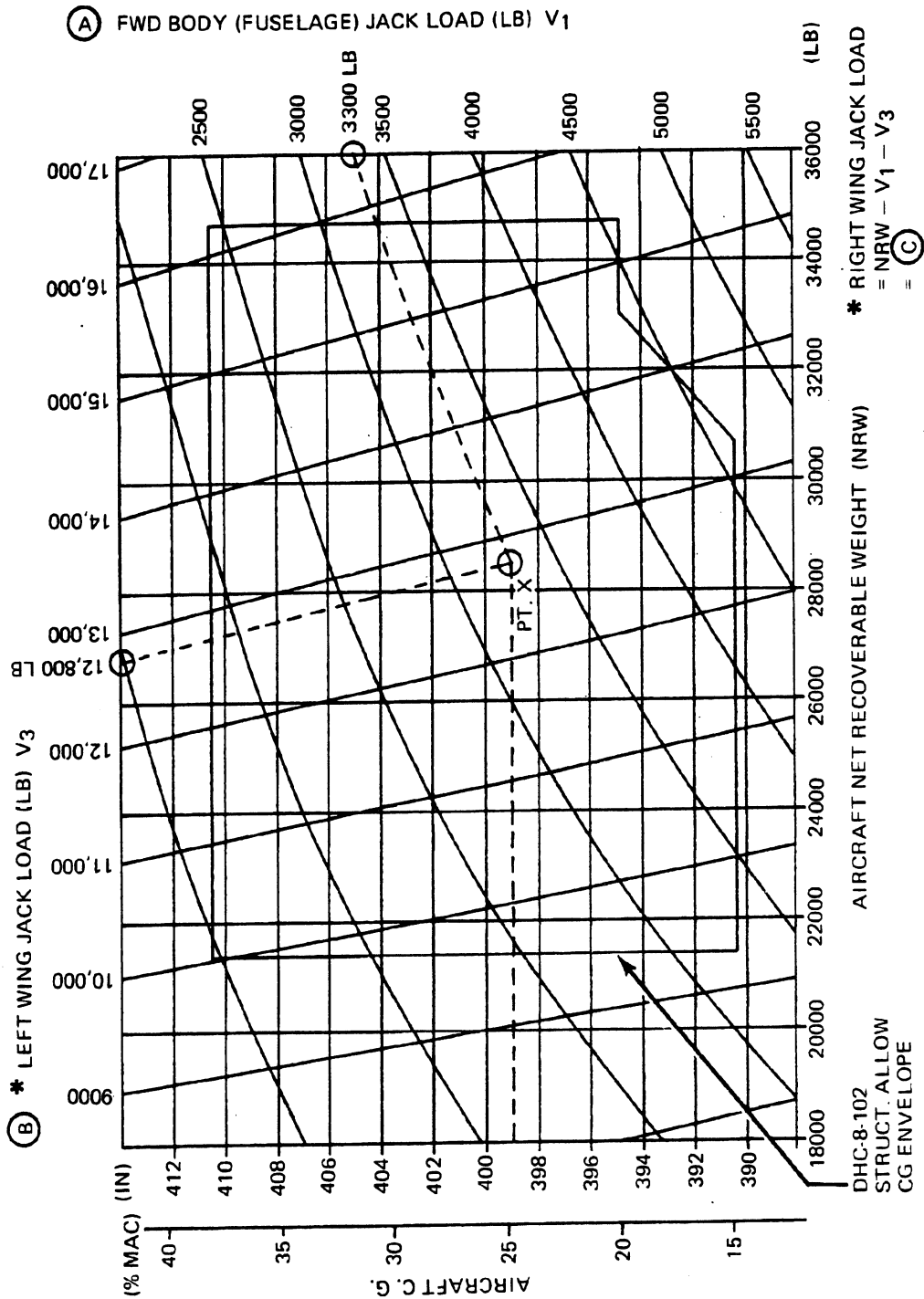

JACK LOAD/NET RECOVERY WEIGHT DETERMINATION

FIGURE 4

2-30-01

DASH 8 AIRCRAFT RECOVERY

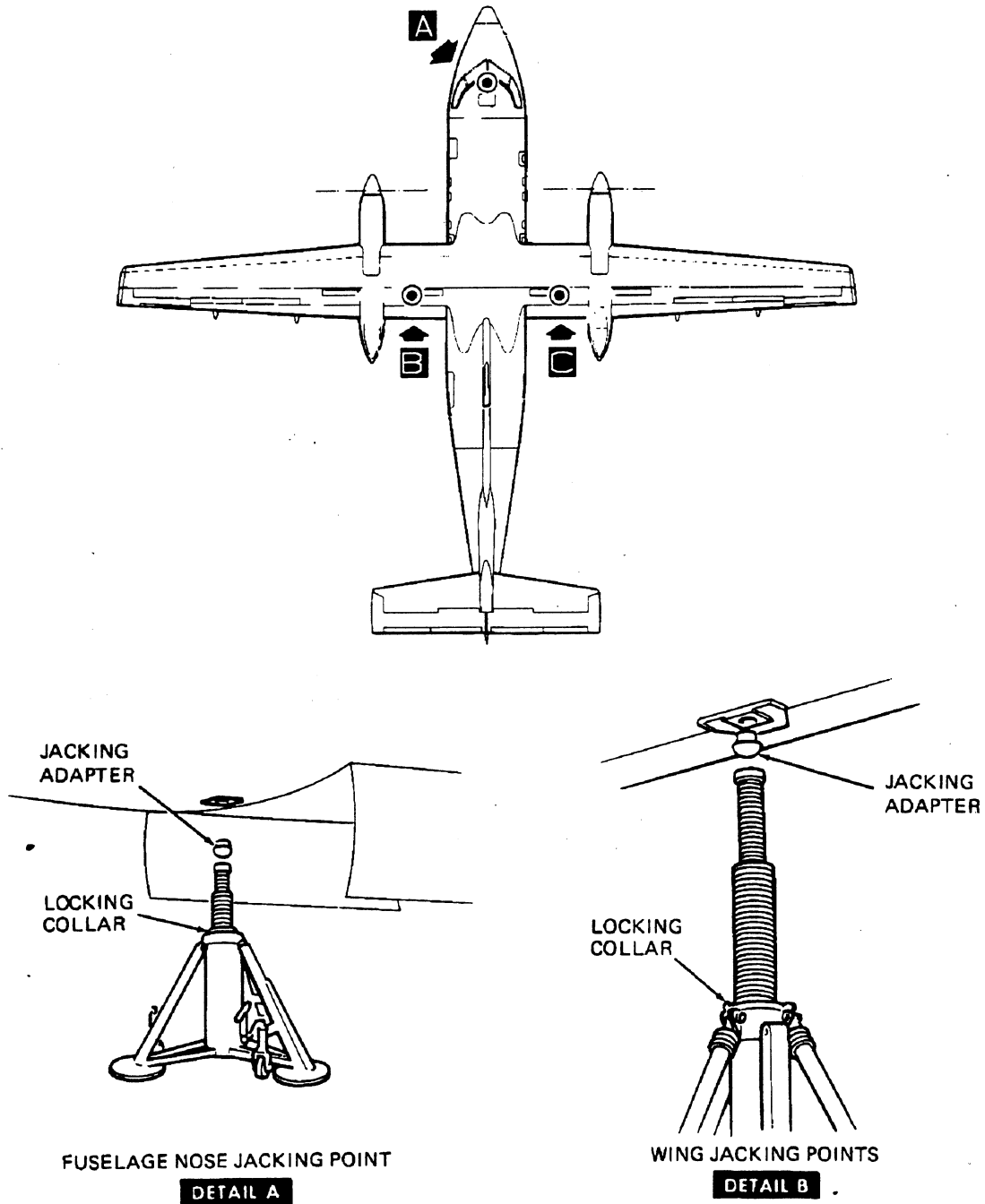

JACKING COMPLETE AIRCRAFT

FIGURE 5

2-30-01

**Boeing Canada**  
de Havilland Division  
**DASH 8 AIRCRAFT RECOVERY**

**THIS PAGE INTENTIONALLY LEFT BLANK**

**2-30-01**

PAGE 10

OCT 10/90

**Boeing Canada**  
de Havilland Division  
**DASH 8 AIRCRAFT RECOVERY**

**REMOVAL OF PAYLOAD**

**1. General**

- A. Removal of payload is necessary as a means of reducing aircraft weight for recovery. It is assumed at this stage that passengers and their carry on luggage have been deplaned.
- B. If the aircraft have come to rest on a unpaved surface, the ordinary loaded units normally used at the terminal may not be useful because of their small wheels and low ground clearances. Vehicles with large tires will probably be required.
- C. When removing cargo, be aware of the effect on the C.G. of aircraft, as any shift in C.G. could rotate aircraft.

**2. Cargo Compartment (Figure 1)**

- A. Baggage and cargo compartment may be configured to carry several combinations of cargo/baggage.
- B. A standard cargo door located on the left rear side of the fuselage provides access for cargo/baggage loading and unloading in all configurations.
- C. A baggage compartment internal access door and lift out panel are located in the rear divider bulkhead.
- D. Left rear divider bulkhead can also be removed to allow access to cargo compartment.
- E. Cargo compartment is divided by a configuration of cargo nets and post (Figure 2).

**2-30-02**

PAGE 1

OCT 10/90

**Boeing Canada**  
de Havilland Division  
**DASH 8 AIRCRAFT RECOVERY**

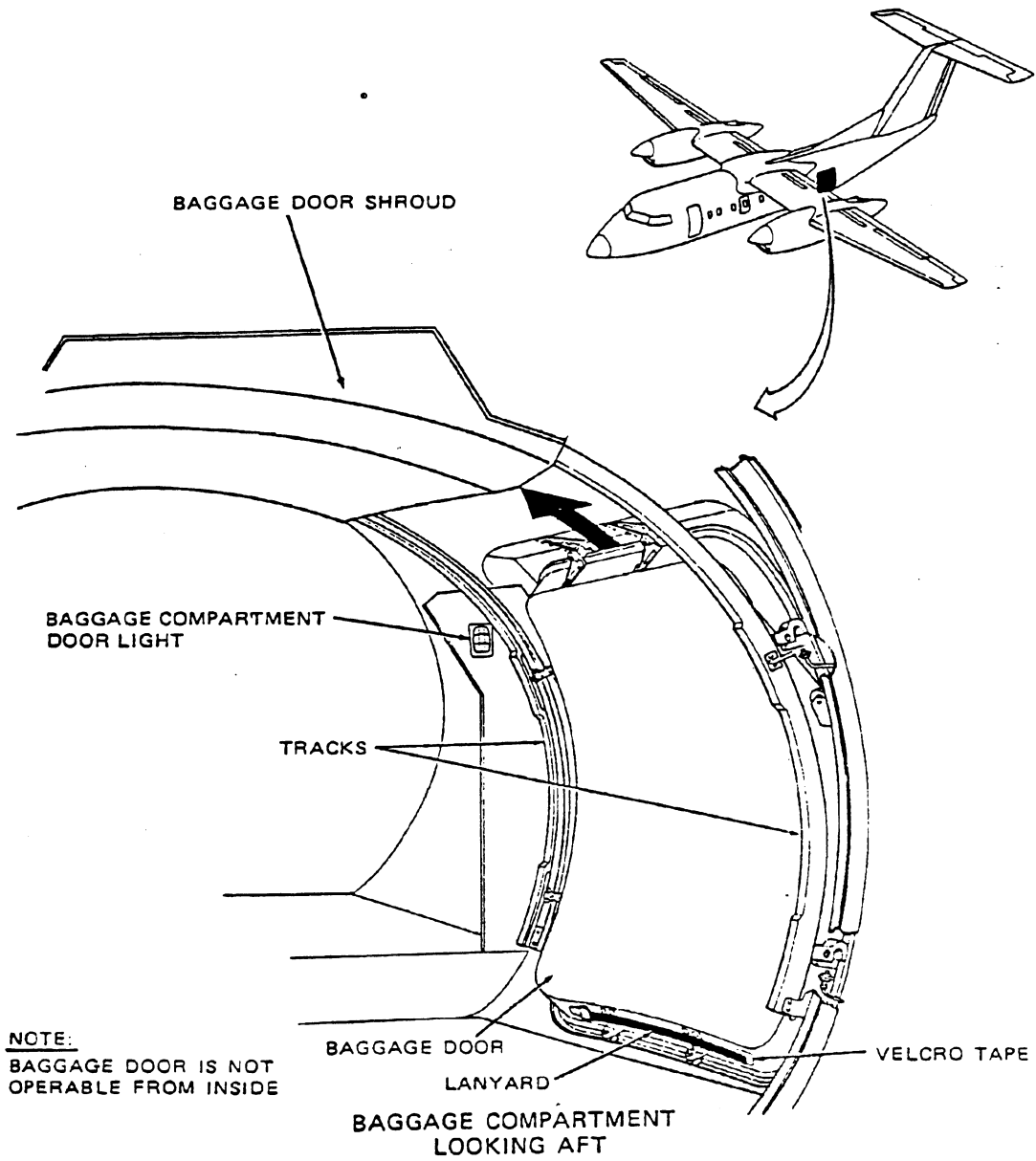

**BAGGAGE DOOR**  
**FIGURE 1 (SHEET 1)**

**2-30-02**



**Boeing Canada**  
de Havilland Division  
**DASH 8 AIRCRAFT RECOVERY**

1

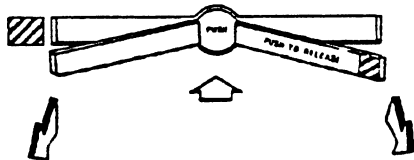

HANDLES SPRING OUT WHEN  
BUTTON IS PRESSED

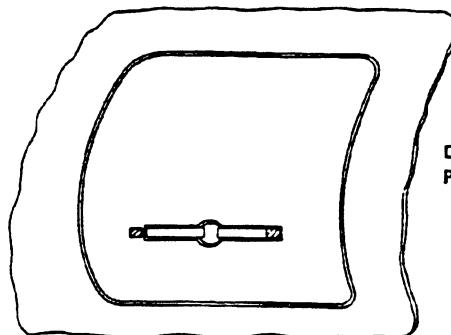

DOOR  
PLUGGED

2

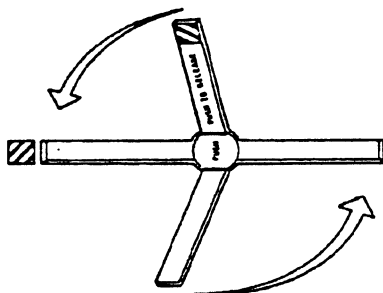

DOOR UNPLUGS (MOVES IN)  
AS HANDLES ARE TURNED 180°

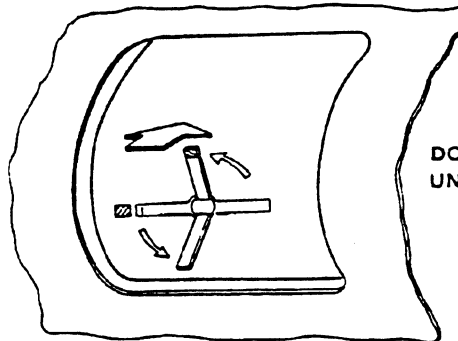

DOOR  
UNPLUGGED

3

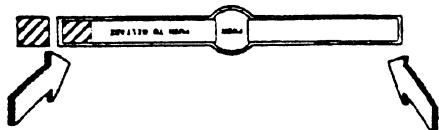

HANDLES ARE PRESSED INTO  
LATCH FLUSH WITH DOOR  
BEFORE RAISING DOOR TO  
OPEN POSITION

NOTE:  
REVERSE ABOVE PROCEDURE  
TO CLOSE DOOR

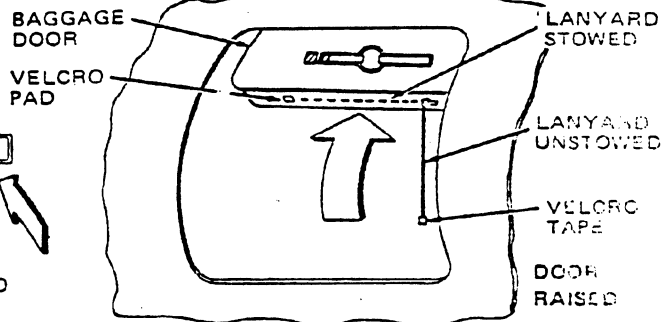

NOTE:  
UNSTOW LANYARD AS REQUIRED FOR  
CLOSING DOOR. ONCE DOOR IS PULLED  
DOWN, RESTOW LANYARD BEFORE  
RE-PLUGGING DOOR.

**BAGGAGE DOOR - OPERATION**  
**FIGURE 1 (SHEET 2)**

**2-30-02**

Boeing Canada  
de Havilland Division  
**DASH 8 AIRCRAFT RECOVERY**

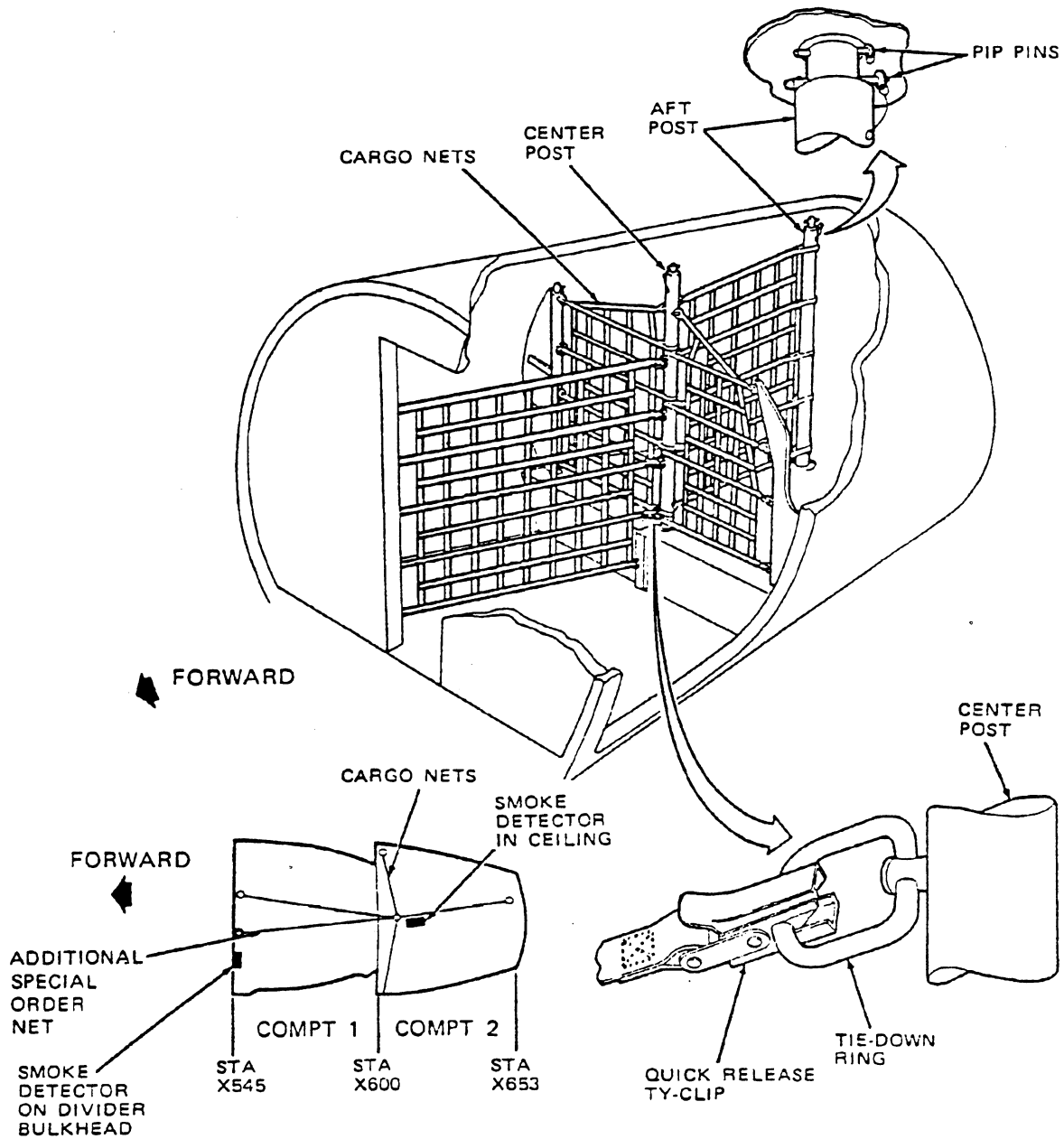

**CARGO NETS**  
**FIGURE 2**

**2-30-02**

DASH 8 AIRCRAFT RECOVERY

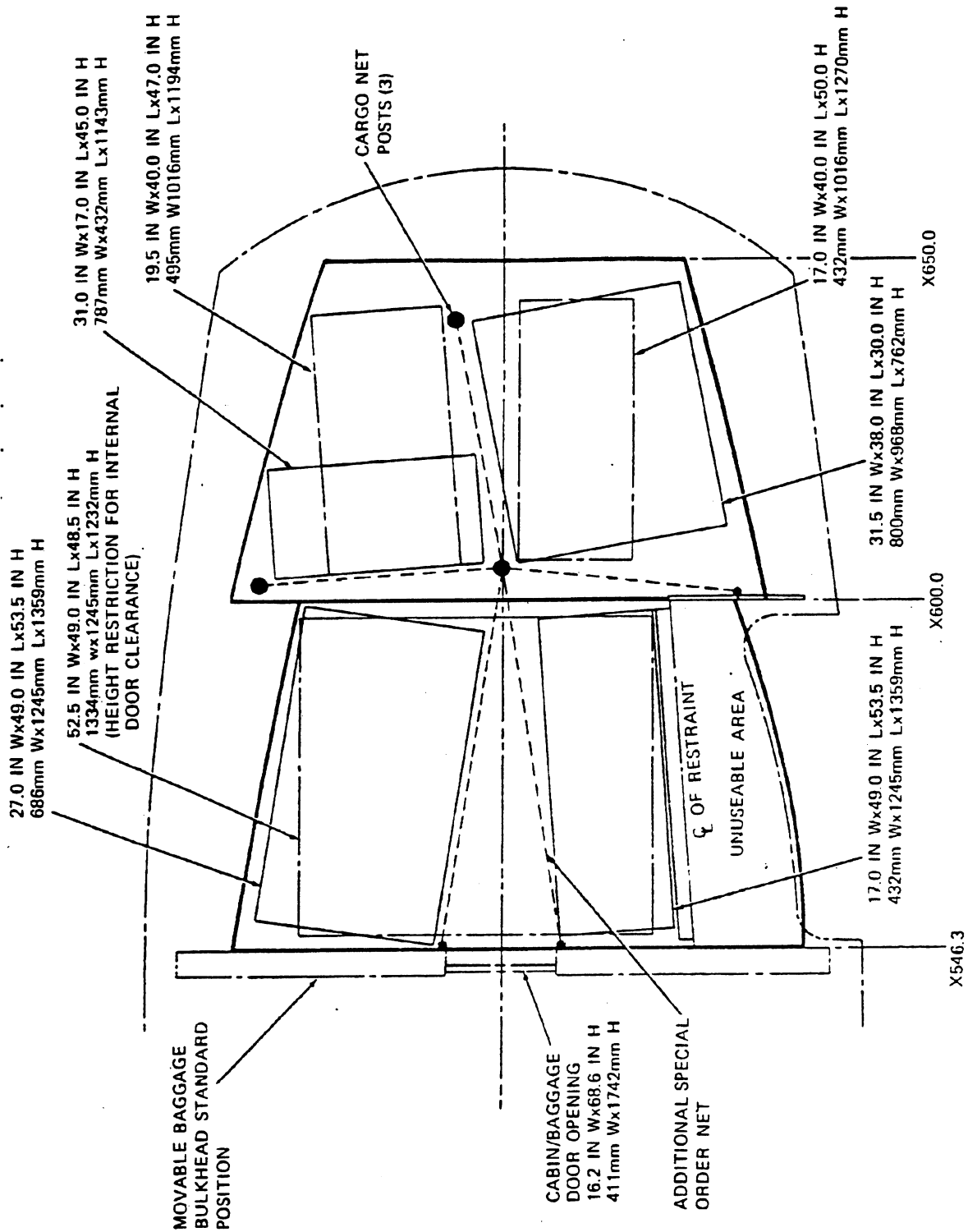

BAGGAGE COMPARTMENT LOADING DIAGRAM

FIGURE 3

2-30-02

DASH 8 AIRCRAFT RECOVERY

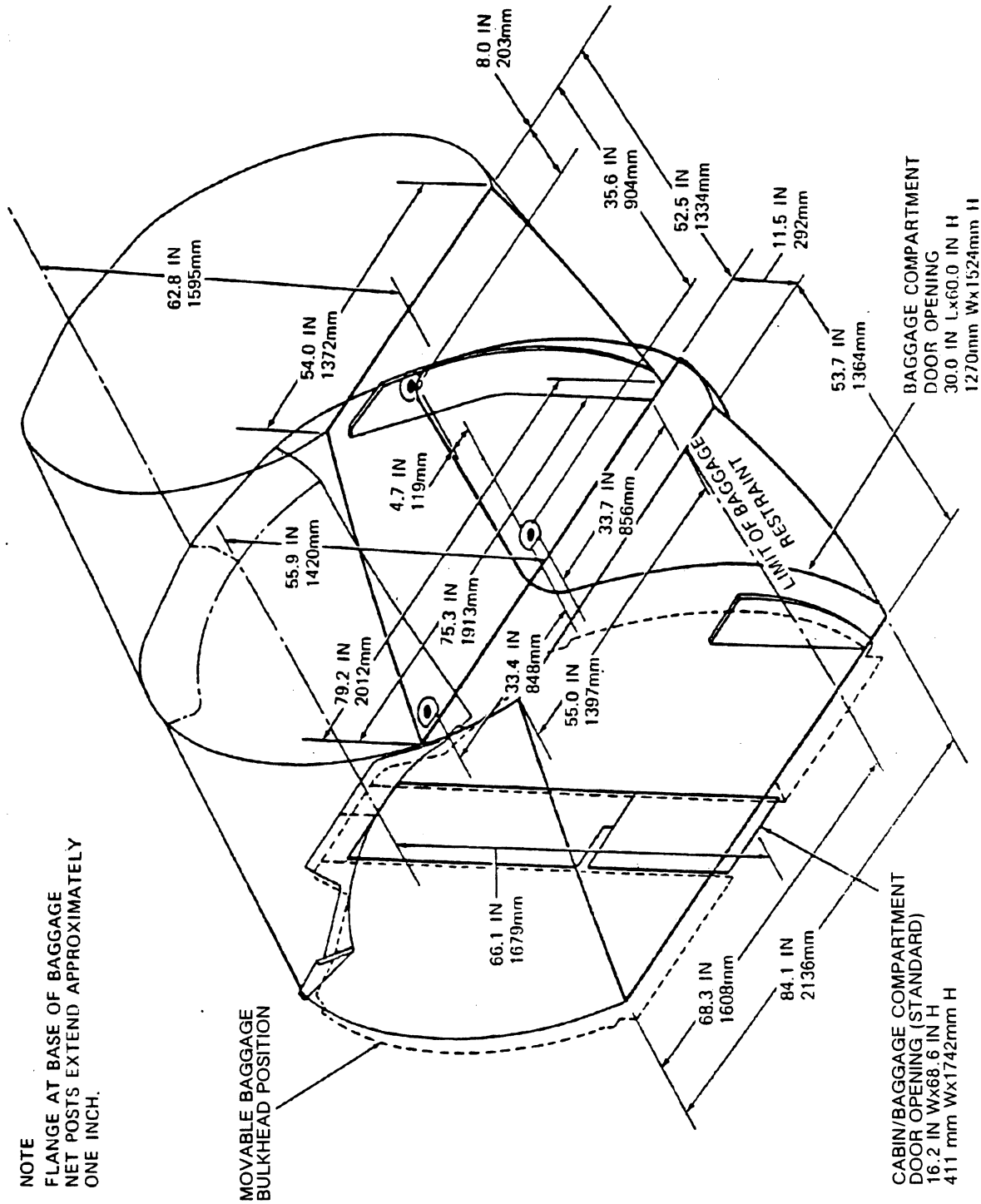

BAGGAGE COMPARTMENT DIMENSIONS

FIGURE 4

2-30-02

**Boeing Canada**  
de Havilland Division  
**DASH 8 AIRCRAFT RECOVERY**

**REMOVABLE COMPONENTS**

**1. General (Figures 1 and 2)**

- A. For the purpose of reducing aircraft weight, payload and some aircraft components may have to be removed. Components to be considered for removal are unused fuel, engines, propellers and seats.
- B. Some components together with their weight and moment arms are listed in this section for both C.T. 142 and C.C. 142.

**2-30-03**

PAGE 1

OCT 10/90

**Boeing Canada**  
de Havilland Division

**DASH 8 AIRCRAFT RECOVERY**

COMPONENTS	WEIGHT POUNDS	ARM INCHES	MO- MENT 1000
ENGINES (QUANTITY 2) PRATT AND WHITNEY P.W. 120A	2323.0	342.5	795.63
PROPELLERS (QUANTITY 2) HAMILTON STANDARD 14-SF-7	631.0	292.6	184.63
BATTERY NO. 1 24V. LEAD ACID G6381E	83.0	88.2	7.32
BATTERY NO. 2 24V. LEAD ACID G6381E	83.0	102.1	8.47
SOO 8070 BATTERY NO. 1 24V. 40 AH.	79.8	88.2	7.04
SOO 8070 BATTERY NO. 2 24V. 40 AH.	79.8	102.1	8.15
A.P.U. INSTALLATION	144.9	682.2	98.85
APU AND OIL	95.3	687.0	65.47
GENERATOR	34.2	672.1	22.99
STARTER	15.4	675.0	10.40
FUEL - MAIN TANKS	5678.0	408.2	2317.76
FUEL - UNUSABLE, DRAINABLE	87.0	408.2	35.51
SOO 8061 LONG RANGE FUEL SYSTEM	+ 125.	395.5	49.44
LONG RANGE - TRAPPED	0	408.2	14.29
LONG RANGE - UNUSABLE, DRAINABLE	35.0	408.2	27.35
	67.0		
WASH WATER - TOILET (5.8 GALLONS - 22 LITRES)	49.0	218.0	10.68
SEAT AND HARNESS - PILOT	37.4	160.3	6.0
SEAT AND HARNESS - CO-PILOT	37.4	160.3	6.0
GALLEY AFT FACING (CONTENTS) (MAXIMUM WEIGHT AS PER LABELS)	245.0	230.0	56.35
GALLEY FORWARD FACING (CONTENTS) (MAXIMUM WEIGHT AS PER LABELS)	150.0	275.0	41.25
WARDROBE (CONTENTS) (MAXIMUM WEIGHT AS PER LABELS)			
ROD	40.0	210.0	8.4
FLOOR	100.0	210.0	21.0
CABIN DIVIDER BULKHEAD (INCLUDING SMOKE DETECTOR AND WIRING)	121.3	543.9	65.98

STANDARD EQUIPMENT

**2-30-03**

PAGE 2

OCT 10/90

**Boeing Canada**  
de Havilland Division

**DASH 8 AIRCRAFT RECOVERY**

COMPONENTS	WEIGHT POUNDS	ARM INCHES	MO- MENT 1000
OVERHEAD BINS			
SMALL BIN (QUANTITY 1)	25.0	328.0	8.20
STANDARD BIN (QUANTITY 5)	40.0	359.0	14.36
	40.0	400.0	16.00
	40.0	440.0	17.60
	40.0	481.0	19.24
	40.0	522.0	29.88
CABIN SEATS (QUANTITY 6)	390.0	425.3	165.87
STUDENT STATION NO. 1	65.0	329.8	21.44
NO. 2	65.0	403.8	26.25
NO. 3	65.0	446.8	29.04
NO. 4	65.0	520.8	33.85
INSTRUCTORS STATION NO. 1	65.0	336.8	21.89
NO. 2	65.0	483.8	31.45
STUDENT CONSOLES (QUANTITY 4)	1062.2	426.8	453.35
CONSOLE STRUCTURE	394.8	424.9	167.75
EQUIPMENT	667.4	427.9	285.58
INSTRUCTOR CONSOLES (QUANTITY 2)	496.6	424.1	210.61
CONSOLE STRUCTURE	165.2	425.1	70.23
EQUIPMENT	331.4	424.1	140.55
REST AREA.	69.8	414.9	28.96
TABLE (TOP AND SUPPORT ASSEMBLY)	20.5	417.0	8.55
SEAT - FORWARD FACING	22.1	445.0	9.83
SEAT - AFT FACING	27.2	388.7	10.57
COMPUTER RACK	395.1	292.5	115.57
STRUCTURE	116.6	287.1	33.48
EQUIPMENT	278.5	294.8	82.10
SEXTANT EQUIPMENT	106.0	280.2	29.70
SEXTANT STANDS (QUANTITY 7)	54.2	297.0	16.10
SEXTANT MOUNTS, FORWARD AND AFT	8.6	280.6	2.41
SEXTANTS AND STOWAGE BOXES (QUANTITY 3)	43.2	259.1	11.19

CT 142  
NAVIGATION TRAINER

**2-30-03**

PAGE 3

OCT 10/90

**Boeing Canada**  
de Havilland Division

**DASH 8 AIRCRAFT RECOVERY**

COMPONENTS	WEIGHT POUNDS	ARM INCHES	MO- MENT 1000
OXYGEN BOTTLES	71.3	381.2	27.18
FLIGHT CREW	17.8	82.0	1.46
WALK AROUND	9.3	178.5	1.66
PORTABLE	9.3	257.5	2.39
REAR CABIN	7.2	540.0	3.89
NAVIGATION CONSOLES	27.7	641.8	17.78
OXYGEN MASKS	28.2	342.2	9.65
FLIGHT CREW (QUANTITY 3)	6.6	177.5	1.17
WALK AROUND	2.5	178.5	0.45
PORTABLE	2.5	257.5	0.64
REAR CABIN	1.0	535.0	0.54
NAVIGATION CONSOLES (QUANTITY 6)	15.6	439.3	6.85
NETS AND POSTS (CARGO AREA)	32.5	608.2	19.77
FIRE EXTINGUISHERS	83.5	518.9	43.33
FLIGHT DECK	5.0	178.9	0.89
FORWARD CABIN	5.0	238.0	1.19
AFT CABIN (QUANTITY 2)	14.1	540.5	7.62
AVIONICS CABINET	5.0	255.5	1.28
BAGGAGE COMPARTMENT	54.4	594.6	32.35
LIFE RAFT INSTALLATION	95.6	616.2	58.91
LIFE RAFT	80.0	616.0	49.28
CRADLE	5.0	617.5	30.9
STRUCTURE ASSEMBLY	10.6	617.5	6.55
DIGITAL FLIGHT DATA RECORDER	25.0	765.0	19.1
COCKPIT VOICE RECORDER	23.9	761.9	18.2

CT 142  
NAVIGATION TRAINER

**2-30-03**

PAGE 4

OCT 10/90



DASH 8 AIRCRAFT RECOVERY

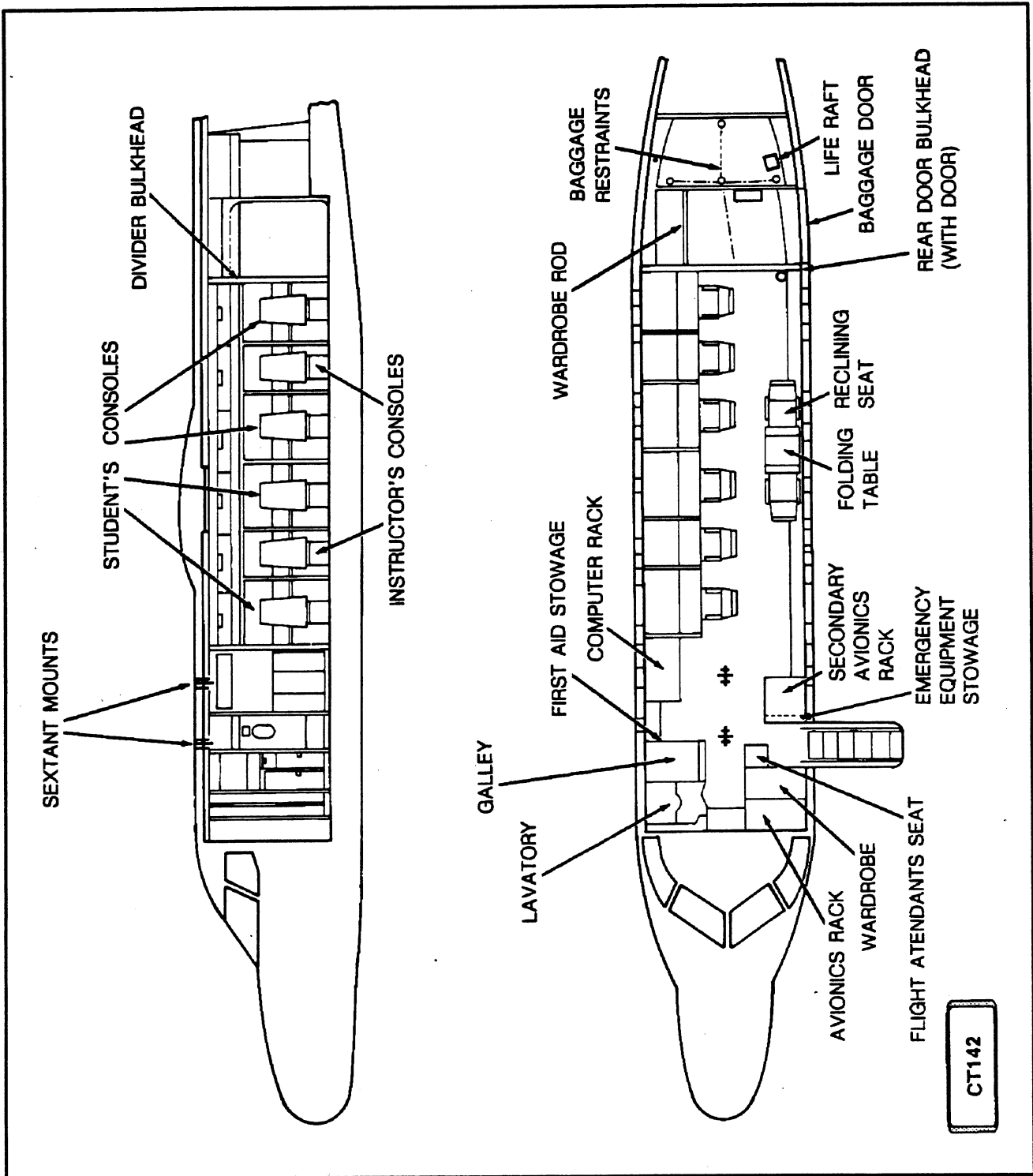

NAVIGATION TRAINER  
CABIN CREW/CARGO COMPARTMENT DIAGRAMS - CT142

FIGURE 1 (SHEET 1)

2-30-03

**Boeing Canada**  
de Havilland Division  
**DASH 8 AIRCRAFT RECOVERY**

NOTE:  
REFER TO CC142  
CABIN DIMENSIONS  
PAGE 12 FOR  
AIRSTAIR DOOR  
"OPEN" DIMENSIONS

OVERHEAD  
BINS CAPACITY -  
2.23 CU FT (0.06 m<sup>3</sup>) PER  
BIN - 15.95 CU FT (0.45 m<sup>3</sup>)  
PER AIRCRAFT

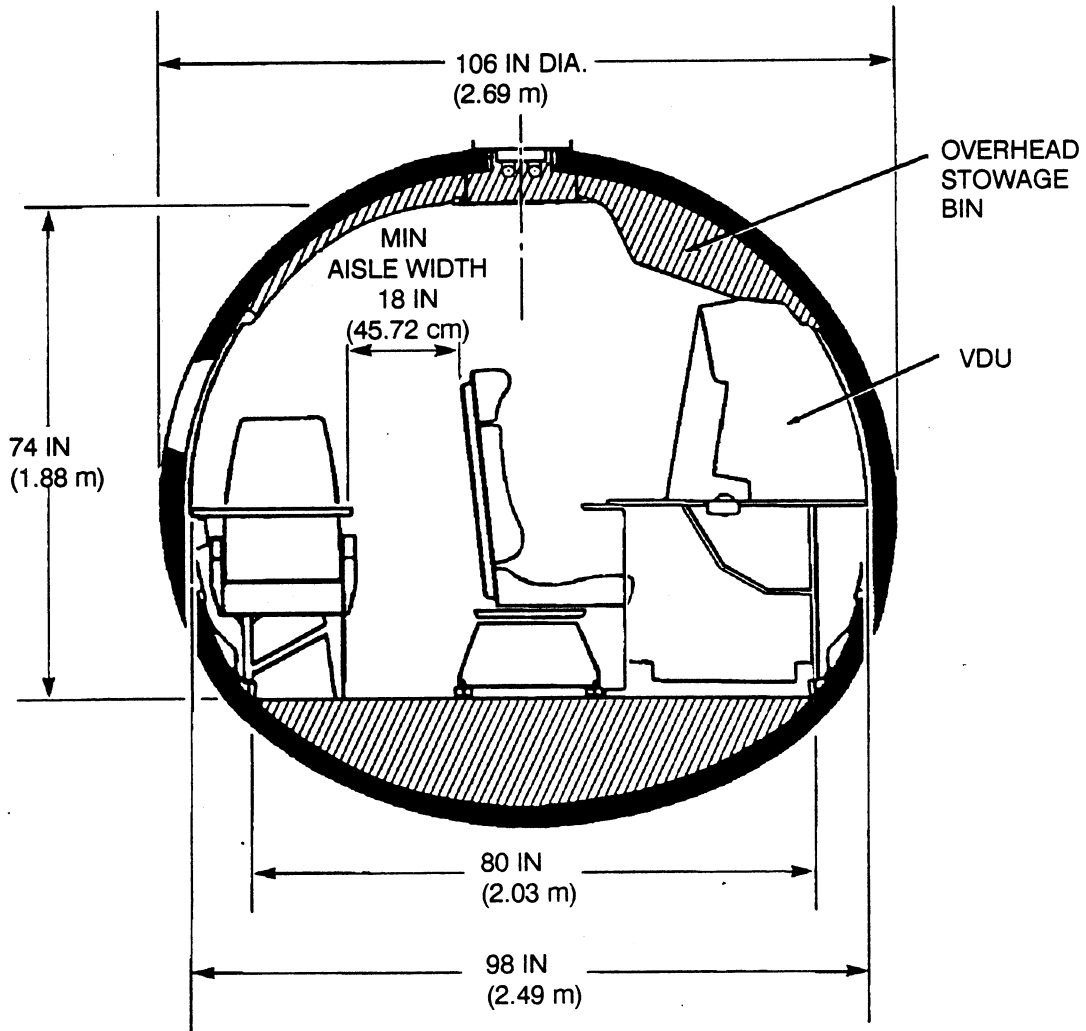

CT142

NAVIGATION TRAINER  
CABIN CREW/CARGO COMPARTMENT DIAGRAMS - CT 142

**2-30-03**

PAGE 6

OCT 10/90

**Boeing Canada**  
de Havilland Division

**DASH 8 AIRCRAFT RECOVERY**

FIGURE 1 (SHEET 2)

COMPONENTS	WEIGHT POUNDS	ARM INCHES	MO- MENT
			1000
CABIN - PASSENGER SEATS (QUANTITY 33)	646.1	418.1	270.13
SEAT - DOUBLE - RECLINE - FIRST ROW L.H.	41.5	310.3	12.88
SEAT - DOUBLE - RECLINE - FIRST ROW R.H.	41.5	310.3	12.88
SEAT - DOUBLE - NON-RECLINE - SECOND ROW L.H.	41.0	341.3	13.99
SEAT - DOUBLE - NON-RECLINE - SECOND ROW R.H.	41.0	341.3	13.99
SEAT - DOUBLE - RECLINE - THIRD ROW L.H.	40.3	374.3	15.08
SEAT - DOUBLE - RECLINE - THIRD ROW R.H.	40.3	374.3	15.08
SEAT - DOUBLE - RECLINE - FOURTH ROW L.H.	41.5	405.3	16.82
SEAT - DOUBLE - RECLINE - FOURTH ROW R.H.	41.5	405.3	16.82
SEAT - DOUBLE - RECLINE - FIFTH ROW L.H.	41.5	436.3	18.11
SEAT - DOUBLE - RECLINE - FIFTH ROW R.H.	41.5	436.3	18.11
SEAT - DOUBLE - RECLINE - SIXTH ROW L.H.	41.5	467.3	19.39
SEAT - DOUBLE - RECLINE - SIXTH ROW R.H.	41.5	467.3	19.39
SEAT - DOUBLE - RECLINE - SEVENTH ROW L.H.	41.5	498.3	20.68
SEAT - DOUBLE - RECLINE - SEVENTH ROW R.H.	41.5	498.3	20.68
SEAT - FIVE ABREAST - EIGHTH ROW L.H. AND R.H.	68.5	529.3	36.26
OR			
CABIN PASSENGER SEATS (QUANTITY 33)	511.7	418.1	213.94
SEAT - DOUBLE - FIRST ROW L.H.	32.1	310.3	9.96
SEAT - DOUBLE - FIRST ROW R.H.	32.1	310.3	9.96
SEAT - DOUBLE - SECOND ROW L.H.	31.7	341.3	10.82
SEAT - DOUBLE - SECOND ROW R.H.	31.7	341.3	10.82
SEAT - DOUBLE - THIRD ROW L.H.	31.0	374.3	11.60
SEAT - DOUBLE - THIRD ROW R.H.	31.0	374.3	11.60
SEAT - DOUBLE - FORTH ROW L.H.	31.7	405.3	12.85
SEAT - DOUBLE - FORTH ROW R.H.	31.7	405.3	12.85
SEAT - DOUBLE - FIFTH ROW L.H.	31.7	436.3	13.83
SEAT - DOUBLE - FIFTH ROW R.H.	31.7	436.3	13.83
SEAT - DOUBLE - SIXTH ROW L.H.	31.7	467.3	14.81
SEAT - DOUBLE - SIXTH ROW R.H.	31.7	467.3	14.81
SEAT - DOUBLE - SEVENTH ROW L.H.	31.7	498.3	15.80
SEAT - DOUBLE - SEVENTH ROW R.H.	31.7	498.3	15.80
SEAT - FIVE ABREAST - EIGHTH ROW L.H. AND R.H.	68.5	529.3	36.26
LITTER CONFIGURATION (FIRST 5 ROWS OF PASSENGER SEATS - DOUBLE)			
CLASS DIVIDER ASSEMBLY - COMPLETE	37.5	449.3	16.85
LITTER MOUNTING ASSEMBLY - FWD (2)	21.8	457.8	9.79
AFT (2)	21.8	532.7	11.61
LITTER - FDC4170 M4 (QUANTITY 2)	40.0	495.3	19.81

CC 142

**2-30-03**

PAGE 7

OCT 10/90

**Boeing Canada**  
de Havilland Division

**DASH 8 AIRCRAFT RECOVERY**

**TRANSPORT**

COMPONENTS	WEIGHT POUNDS	ARM INCHES	MO- MENT 1000
LOW DENSITY CONFIGURATION			
CLASS DIVIDER ASSEMBLY - COMPLETE	37.5	389.3	14.60
FOLDING TABLE LEFT HAND	20.0	456.0	9.12
FOLDING TABLE RIGHT HAND		456.0	
REFRESHMENT UNIT LEFT SIDE		527.5	
SEAT - SINGLE - AFT FACING - ROW 4 L.H.	27.2	431.0	11.72
SEAT - SINGLE - FWD FACING - ROW 5 L.H.	22.1	481.0	10.63
SEAT - DOUBLE - AFT FACING - ROW 4 R.H.		431.0	
SEAT - DOUBLE - RECLINE - FWD FACING ROW 5 R.H.	41.5	481.0	19.96
SEAT - DOUBLE - RECLINE - FWD FACING ROW 6 R.H.	41.5	516.0	21.41
OXYGEN BOTTLES	60.2	196.8	11.85
FLIGHT CREW	17.8	82.0	1.46
WALK AROUND	9.3	178.5	1.66
OXYGEN BOTTLES CABIN (QUANTITY 2)	14.4	271.8	3.91
OXYGEN BOTTLES AVIONICS CABINET (QUANTITY 2)	18.7	257.5	4.82
OXYGEN MASKS	19.9	225.5	4.49
CREW	6.6	177.5	1.17
WALK AROUND	2.5	180.0	0.45
BINS (QUANTITY 4)	5.9	271.9	1.60
AVIONICS CABINET (QUANTITY 2)	4.9	257.5	1.26
FIRE EXTINGUISHERS	76.4	536.7	41.00
FLIGHT DECK	5.0	178.9	0.89
CABIN - FORWARD	5.0	255.3	1.28
CABIN - AFT	5.0	540.5	2.70
CABIN - AFT	7.0	540.5	3.78
BAGGAGE COMPARTMENT	54.4	594.6	32.35
NETS AND POSTS CARGO AREA	27.5	609.6	16.76
DIGITAL FLIGHT DATA RECORDER	25.0	765.0	19.1
COCKPIT VOICE RECORDER	23.9	761.9	18.2

DASH 8 AIRCRAFT RECOVERY

TRANSPORT

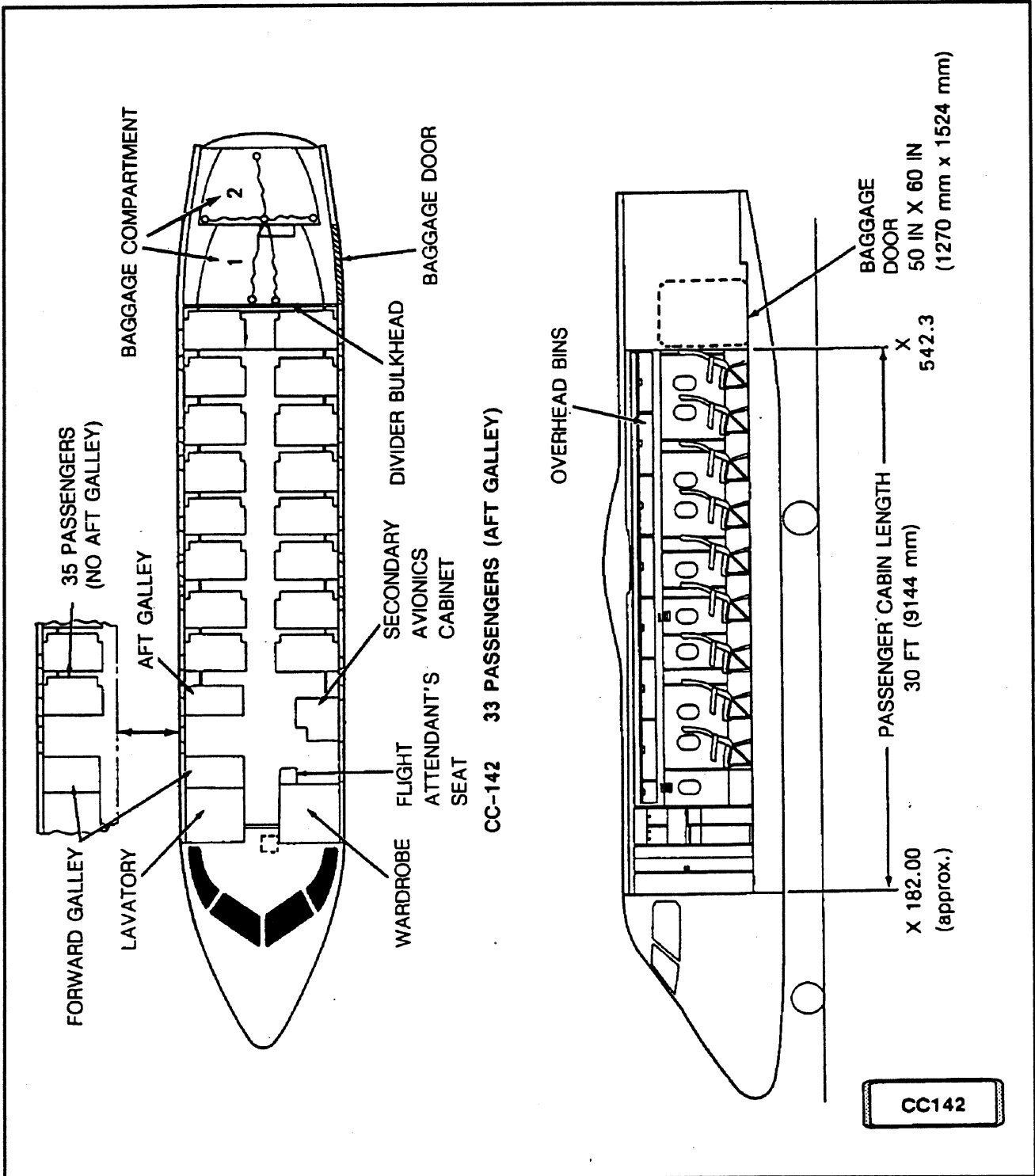

PASSENGER/CARGO COMPARTMENT 33 SEATS

FIGURE 2

2-30-03

**Boeing Canada**  
de Havilland Division  
**DASH 8 AIRCRAFT RECOVERY**

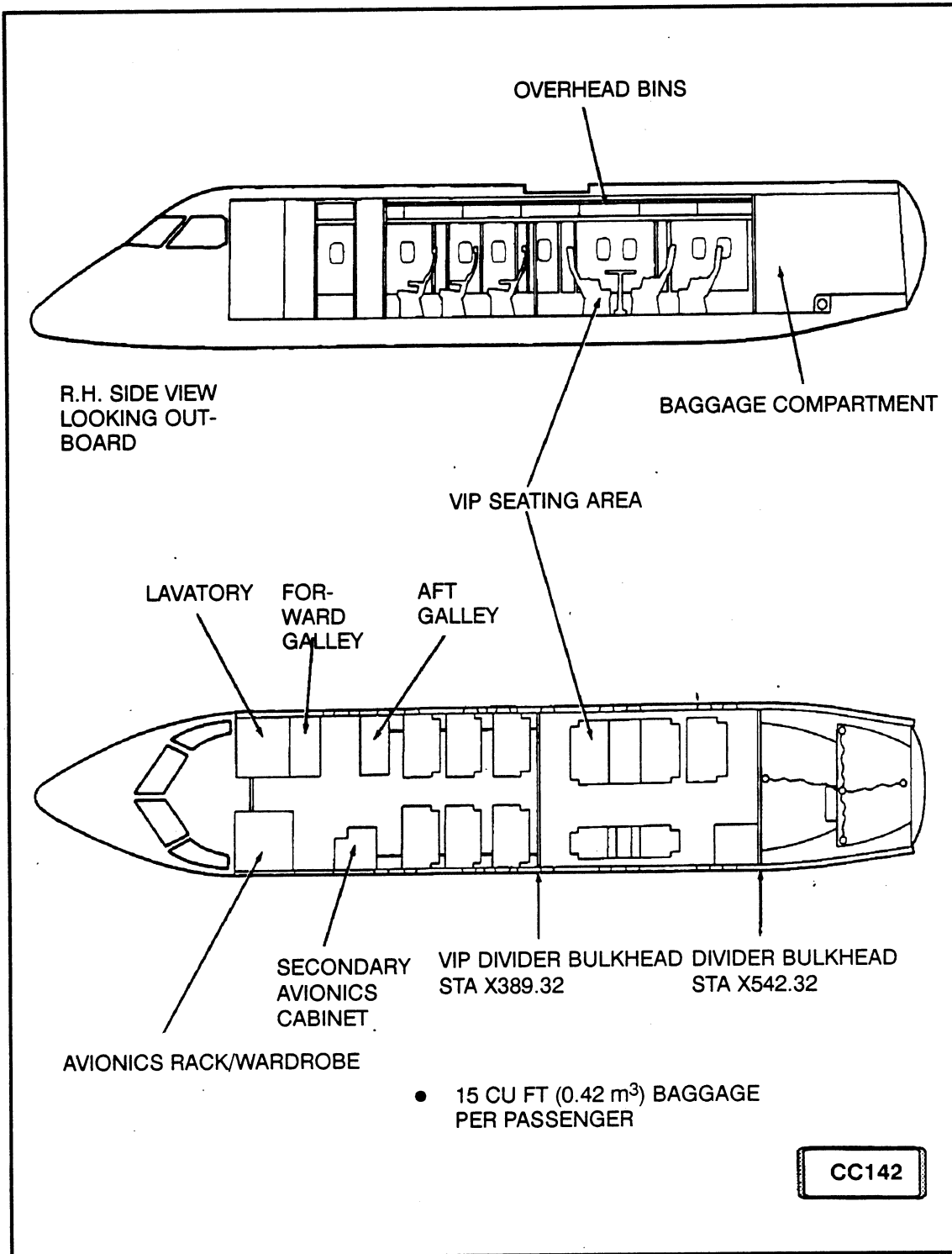

PASSENGER/LOW DENSITY  
FIGURE 3

**2-30-03**

**Boeing Canada**  
de Havilland Division  
**DASH 8 AIRCRAFT RECOVERY**

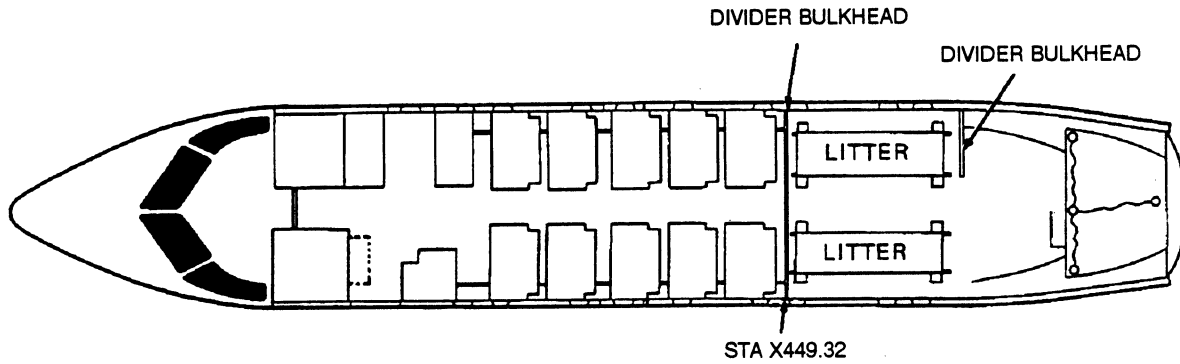

LITTER VERSION

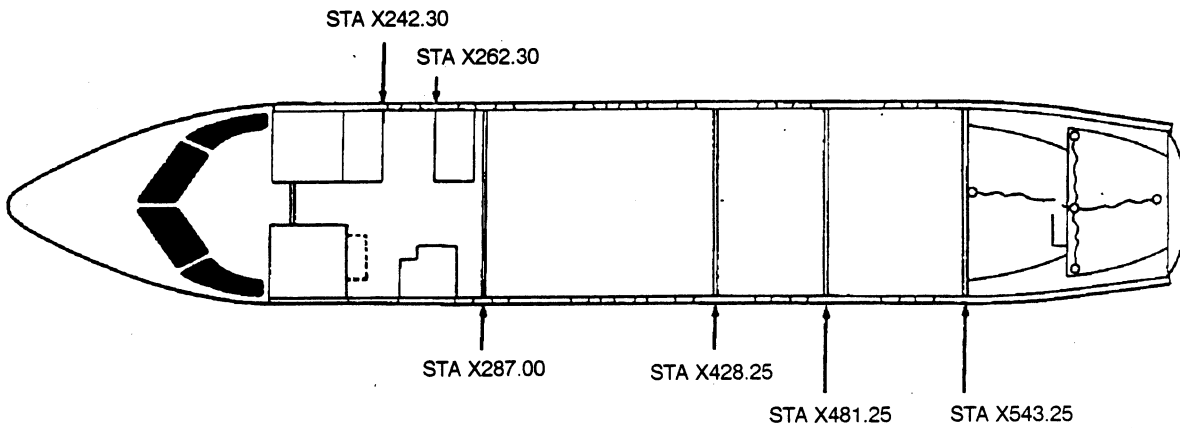

NOTE: THE INDICATED STATION LOCATIONS ARE ALTERNATE LOCATIONS FOR THE DIVIDER BULKHEAD. THE DIVIDER BULKHEAD IS INSTALLED AT ONLY ONE STATION.

CARGO VERSION

**PASSENGER/CARGO COMPARTMENTS - LITTERS**  
**FIGURE 4**

**2-30-03**

**DASH 8 AIRCRAFT RECOVERY**

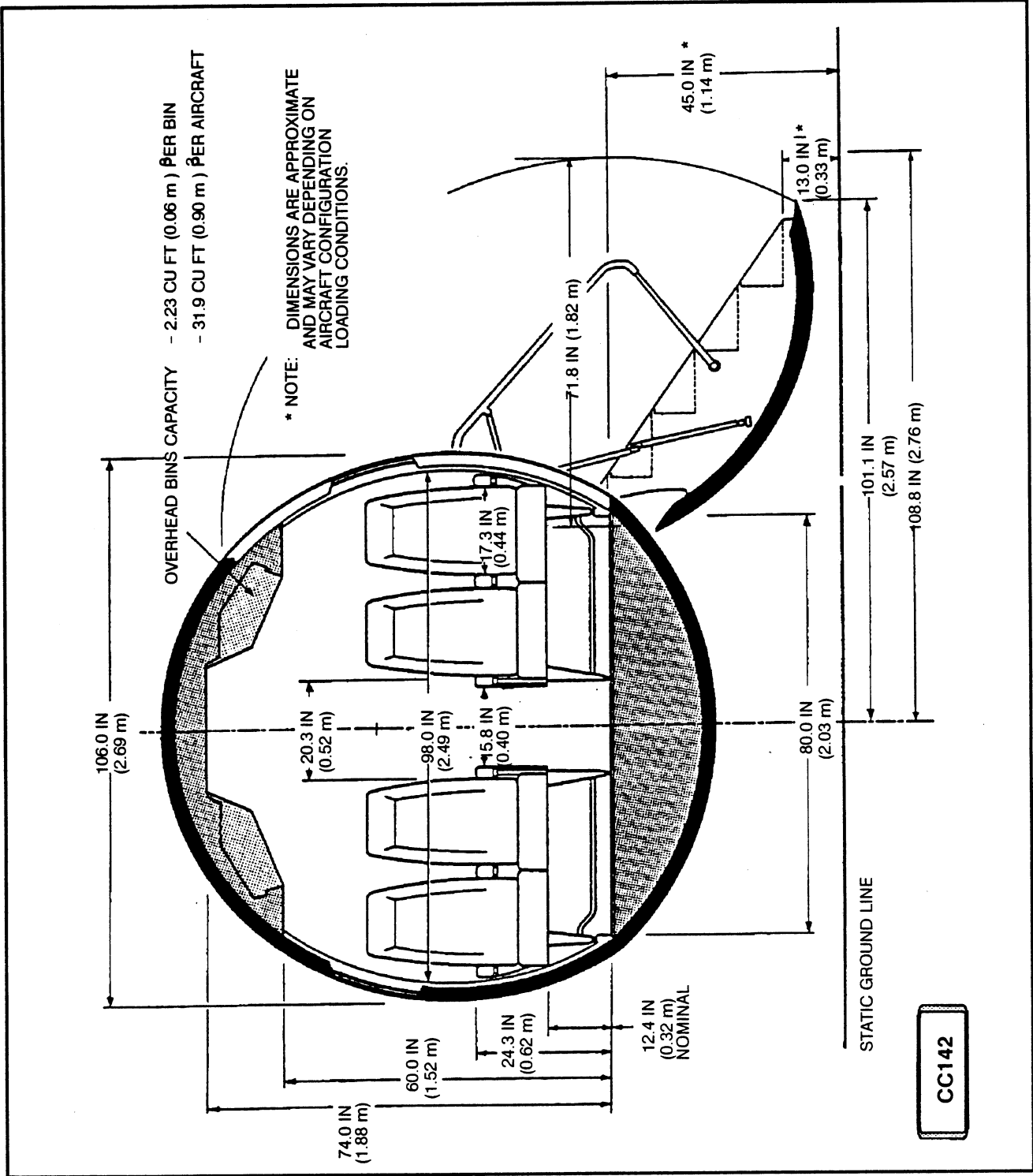

PASSENGER/CARGO COMPARTMENTS - LITTERS

FIGURE 5

**2-30-03**



## DASH 8 AIRCRAFT RECOVERY

### DEFUELING

#### 1. General (Figures 1)

##### A. Description/Operation

- (1) Fuel is contained in four integral wing tanks, two main tanks and two auxiliary tanks. Fuel from each auxiliary tank is fed to its associated main tank by an auxiliary tank pumping system contained in the main tank. Fuel from each main tank is fed to its associated engine by an engine feed pumping system contained in a collector bay at the inner end of the tank. The fuel level in the collector bay is maintained by a collector bay pumping system to provide engine feed regardless of aircraft attitude. The tanks are vented through vent float valves and vent lines from each tank to a surge bay at the outer end of the main tank.
- (2) Pressure refueling and defueling can be accomplished through a single point refuel/defuel adapter located in the right nacelle and is controlled from an adjacent refuel/defuel control panel. As an alternative to pressure refueling, each tank can be filled through an overwing filler point.
- (3) Each tank has its own capacitance type fuel quantity indicating system which provides an input to control pressure refueling/defueling levels in addition to its primary function. Fuel low level warnings are also provided for each main tank.
- (4) Defueling is essential before lifting the aircraft so that the weight of the aircraft is reduced and potential fire hazard is minimized. The amount of fuel in the aircraft may be significant enough to shift the center of gravity when the aircraft is righted from an abnormal attitude. Due to the abnormal attitude of the aircraft the defueling procedure may deviate somewhat from the norm and require more time. Before any defueling is attempted, determine from weight and balance calculations how the amount or quantity of fuel to be removed will affect the C.G. location.
- (5) While some recovery operations do not need defueling, the decision to do so or not must be arrived at only after a study of the effects of such action on jacking loads, center of gravity shift, towing loads and safety considerations.

**WARNING:** FUEL VAPORS ARE EXTREMELY EXPLOSIVE AND EVERY PRECAUTION MUST BE TAKEN TO PREVENT IGNITION. SAFETY PRECAUTIONS ARE PROVIDED TO PREVENT INJURY TO PERSONNEL AND/OR DAMAGE TO EQUIPMENT, AND TO ALERT PERSONNEL TO THE HARMFUL EFFECTS OF FUEL COMING IN CONTACT WITH EYES AND SKIN AND INHALATION OF FUEL VAPORS.

**CAUTION:** FUEL TANKS MUST BE DRAINED AND WINGS SUPPORTED PRIOR TO REMOVAL OF OVERWING ACCESS PANELS. IF NOT DAMAGE WILL OCCUR TO TRI-WING BOLTS AND ANCHOR NUTS. ALSO PANELS WILL NOT FIT ON INSTALLATION.

##### B. Safety Precautions

- (1) Smoking and any other kind of open flame is not allowed in the vicinity of the aircraft.

**2-30-04**

## **DASH 8 AIRCRAFT RECOVERY**

- (2) Adequate fire extinguishing equipment, and personnel familiar with its use, must be immediately available and standing by at all times.
  - (3) Ensure that aircraft is correctly grounded and, if a suction defueling operation is in progress, ground fuel tender (Figure 2).
  - (4) Ensure that all electrical power is off except when suction defueling is in progress. During suction defueling, all electrical services must be off, except those required for monitoring the operation.
  - (5) Avoid carrying out other work on the aircraft until fuel tank(s) is completely drained, purged of fuel vapors, and checked safe.
  - (6) Avoid fuel spillage as this will greatly increase the fire hazard. If fuel is spilled, all operations must cease in the vicinity until the spill is cleaned up and the area checked safe by fire personnel.
  - (7) Only vapor/explosion proof lamps, with good electrical connections and serviceable extension cords, must be used inside or in the vicinity of open fuel tanks.
  - (8) Personnel must take every precaution to avoid fuel contacting eyes and skin, inhalation of fuel vapors, and accidental swallowing of fuel. Anyone exposed to these conditions must wash contacted areas thoroughly with water and seek medical attention promptly.
  - (9) Fuel tanks must not be entered until completely drained, purged of fuel vapors, and checked safe. All access panels must be open or removed.
  - (10) Protective clothing of cotton material should be worn when carrying out work inside a fuel tank. Do not use any article made from nylon due to static electricity build-up.
  - (11) A continuous flow of ventilating air should be maintained through a fuel tank when work is being carried out inside.
- C. Pressure Defueling (Figure 3 Sheets 1 and 2)
- (1) Observe precautions detailed in para 1.B.
  - (2) Apply external electrical power to ac and dc bus systems. Refer to APPLICATION AND REMOVAL OF ELECTRICAL POWER.

**2-30-04**

PAGE 2

OCT 10/90

## **DASH 8 AIRCRAFT RECOVERY**

**NOTES: 1. If ac power is not available, defueling will be by suction from the fuel tender only. Auxillary pumps will not operate and pump advisory lights will not come on.**

**2. A method of defueling auxillary tanks, if installed is to transfer the fuel from the auxillary tank to its associated main tank (refer to AUXILIARY TANK FUEL TRANSFER SYSTEM - DESCRIPTION AND OPERATION).**

- (3) Open access door to aircraft refuel/defuel control panel and observe that panel lights and MASTER VALVE CLOSED light and LINE VALVE CLOSED lights (SOO 8061) come on.

**WARNING: ENSURE THAT FUEL TENDER, FUELING CONNECTION, AND AIRCRAFT ARE PROPERLY GROUNDED (FIGURE 2).**

- (4) Remove cap from hose on fuel tender and from refuel/defuel adapter on aircraft and connect hose to adapter.
- (5) Turn load limit selector knobs on repeater indicators at refuel/ defuel control panel to set rim pointers (bugs) to zero.

**NOTE: When a tank or tanks are not being completely defueled, set rim pointers (bugs) on appropriate repeater indicators to desired readings.**

- (6) Select DEFUEL on rotary selector switch on refuel/defuel control panel and observe the following:
- (a) POWER ON light at refuel/defuel control panel comes on.
  - (b) FUELING ON caution light at the caution lights panel in flight compartment comes on.
  - (c) AUX PUMP advisory lights on fuel control panel come on.
  - (d) MASTER VALVE CLOSED light on refuel/defuel control panel goes off.
  - (e) LINE VALVE CLOSED lights (SOO 8061) on refuel/defuel control panel go off (only if aux tanks contain fuel).
- (7) When both auxiliary pump advisory lights go off to indicate that defueling operation is complete, turn rotary selector switch to OFF. Observe that POWER ON light and FUELING ON caution light are off and MASTER VALVE CLOSED light comes on.
- (8) If tanks are only partially defueled, check that repeater indicators at refuel/defuel control panel register the fuel quantity selected and that corresponding master indicators in flight compartment show the same readings.

**2-30-04**

## DASH 8 AIRCRAFT RECOVERY

- (9) Disconnect fuel tender hose from defueling adapter and install caps.
- (10) Close and secure refuel/defuel control panel access door.
- (11) Remove external electrical power from ac and dc bus systems. Refer to APPLICATION AND REMOVAL OF ELECTRICAL POWER.

### D. Gravity Defueling (Figure 4 Sheet 1 and 2)

#### Equipment and Materials:

Manual defueling adapter, Pt. No. RG53165 (Lear Siegler)

- (1) Observe precautions detailed in para 1.B.
- (2) Remove auxiliary pump plug-in element (refer to PSM 1-8-2 Chapter 28).
- (3) Install manual defueling adapter RG53165 and a one inch hose at location from which pump element was removed.
- (4) Turn adapter clockwise and defuel tank.

**NOTE:** If tanks are not being completely defueled, power is required on the aircraft buses to operate the fuel quantity indicating system in order to monitor the amount of fuel remaining in the tank. Magnetic dipsticks may also be used to monitor fuel quantity.

- (5) Remove adapter from auxiliary pump canister and reinstall auxiliary pump plug-in element (refer PSM 1-8-2 to Chapter 28).

**DASH 8 AIRCRAFT RECOVERY**

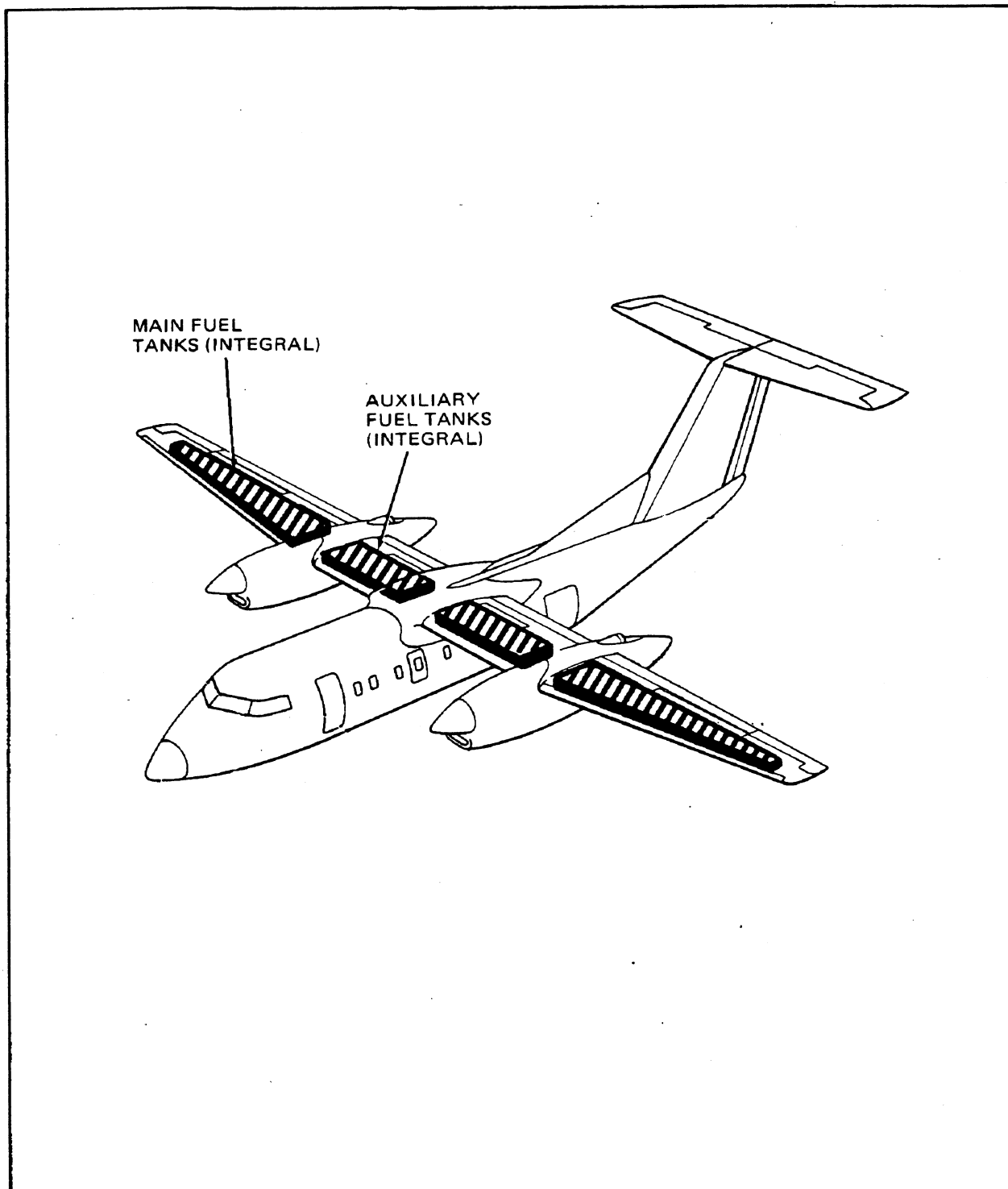

**FUEL TANKS**  
**FIGURE 1**

**2-30-04**

**DASH 8 AIRCRAFT RECOVERY**

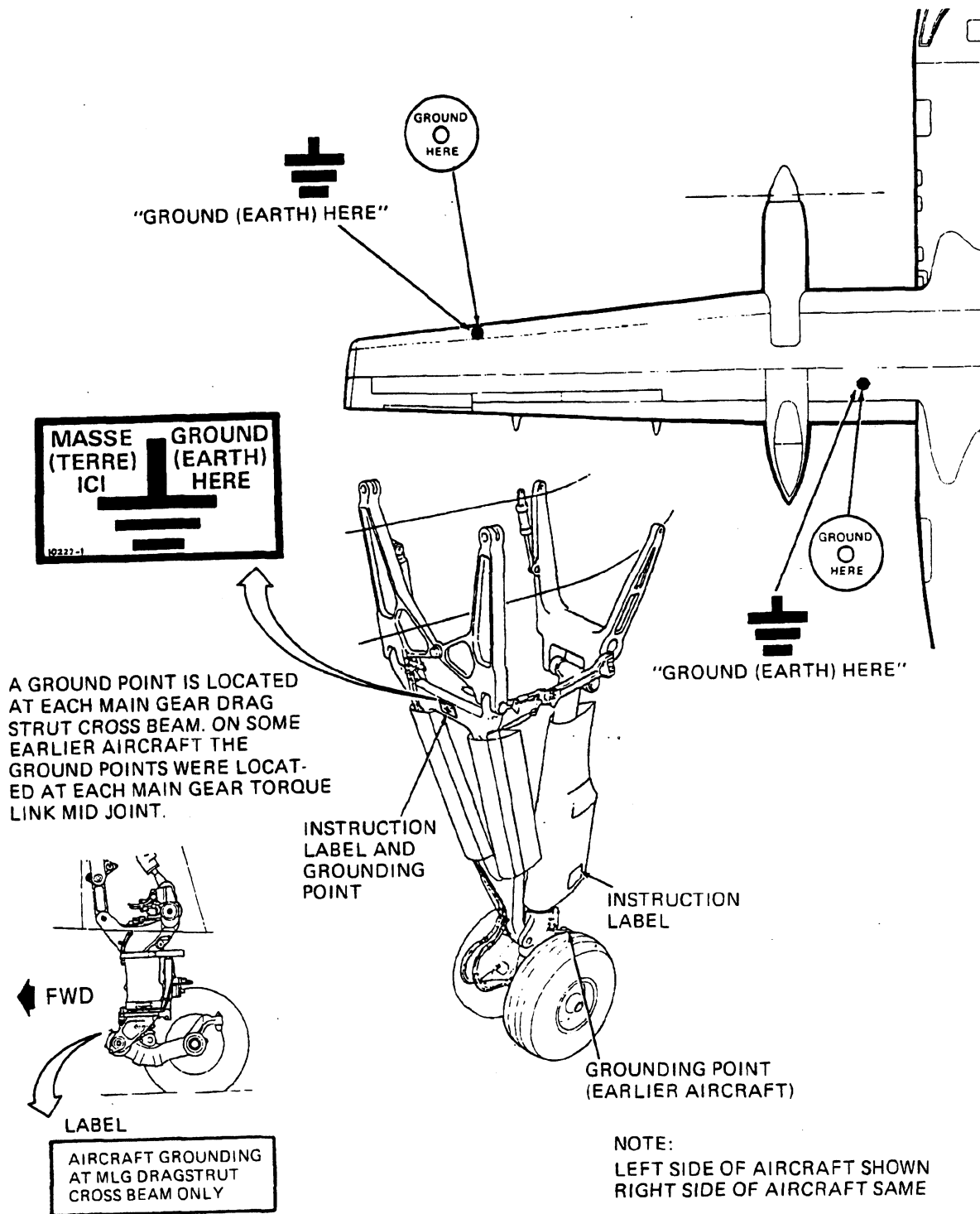

**AIRCRAFT GROUND POINTS**

**FIGURE 2**

**2-30-04**

## DASH 8 AIRCRAFT RECOVERY

Location	Tank Capacity (approx)			SG = 0.816 Weight (approx)	
	U.S. Gal.	Imp. Gal.	Litres	Lb.	Kg.
No. 1 Tank (Left wing)	423	352	1601	2882	1307
No. 2 Tank (Right wing)	423	352	1601	2882	1307
<b>TOTAL (STANDARD)</b>	<b>846</b>	<b>704</b>	<b>3202</b>	<b>5764</b>	<b>2614</b>
No. 1 Aux Tank (Left wing) (S.O.O. 8061)	354	295	1341	2400	1089
No. 2 Aux Tank (Right wing) (S.O.O. 8061)	354	295	1341	2400	1089
<b>TOTAL ALL TANKS</b>	<b>1554</b>	<b>1294</b>	<b>5884</b>	<b>10564</b>	<b>4792</b>

**FUEL SPECIFICATION**

FUEL MUST CONFORM TO P AND W (CANADA) SPECIFICATION CPW 204.

### FUEL TANK CAPACITIES AND FUEL WEIGHTS

<b>ELECTRIC POWER</b>	28 VOLTS DC POWER MUST BE AVAILABLE FROM INTERNAL OR EXTERNAL SOURCE. ENSURE ALL INVERTER CIRCUIT BREAKERS CLOSED.
<b>FUELING PRESSURE</b>	50 PSI (3.515 KG/SQ CM) MAXIMUM
<b>FUELING FLOW RATE</b>	40 U.S. GALLONS (151 LITRES) (33 IMPERIAL GALLONS) AT 50 PSI MAX.
<b>AIRCRAFT CONNECTOR</b>	ADAPTER – 2810070-101 PARKER HANNIFIN (MS2448-4-2)
<b>MATING GROUND CONNECTOR</b>	ANY STANDARD FUELING NOZZLE CONFORMING TO MS29520-1
<b>GROUNDING PROVISION</b>	AIRCRAFT CONNECTOR – MS90298-2 MATING GROUND CONNECTOR – MS3493

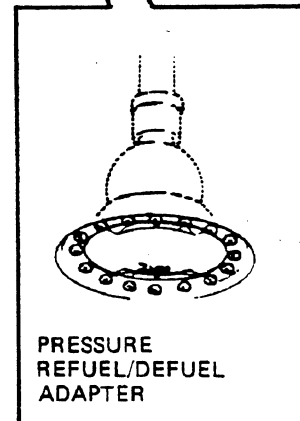
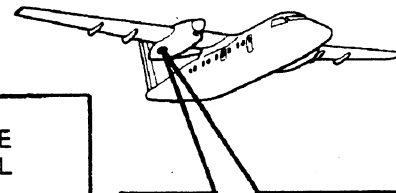

PRESSURE  
REFUEL/DEFUEL  
ADAPTER

**PRESSURE REFUELING/DEFUELING REQUIREMENTS**

FIGURE 3 (SHEET 1)

**2-30-04**

**DASH 8 AIRCRAFT RECOVERY**

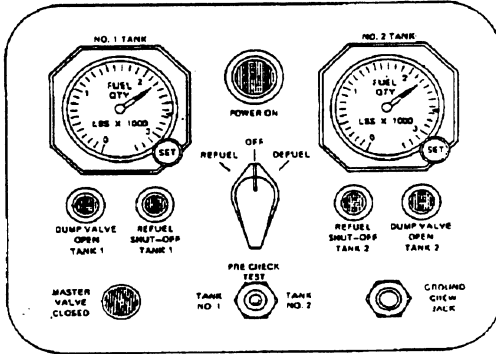
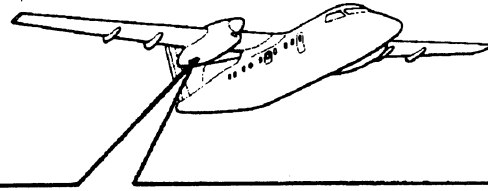

**STANDARD  
FUEL SYSTEM**

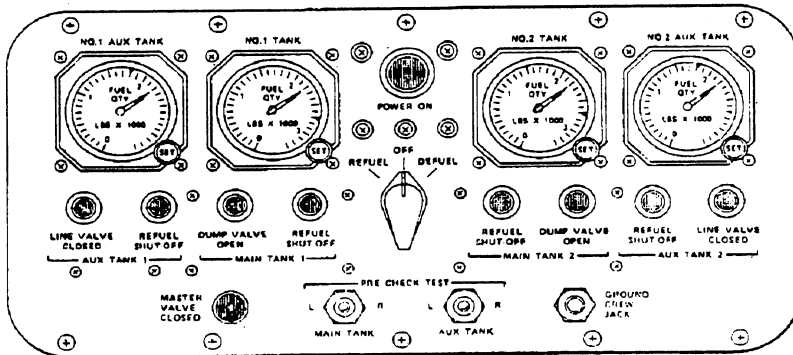

**LONG RANGE  
FUEL SYSTEM**

**REFUEL/DEFUEL PANELS**

**CAUTION:**

BEFORE PERFORMING ANY REFUELING OR DEFUELING OPERATIONS ENSURE THAT BOTH THE AIRCRAFT AND THE FUEL TENDER ARE GROUNDED. BEFORE CONNECTING FUEL TENDER HOSE TO REFUEL/DEFUEL ADAPTER, GROUND THE HOSE TO ADJACENT GROUNDING SOCKET.

**NOTE:**

WATER AND/OR CONTAMINANTS MUST BE DRAINED PERIODICALLY FROM FUEL TANKS AND FUEL FILTERS.

DRAIN VALVES ARE PROVIDED IN UNDERWING SURFACES AND IN BOWL OF EACH FUEL FILTER.

OPEN EACH VALVE AND HOLD UNTIL CLEAN FUEL ONLY IS EJECTED, THEN CLOSE VALVE.

**PRESSURE REFUELING/DEFUELING**

**FIGURE 3 (SHEET 2)**

**2-30-04**



## DASH 8 AIRCRAFT RECOVERY

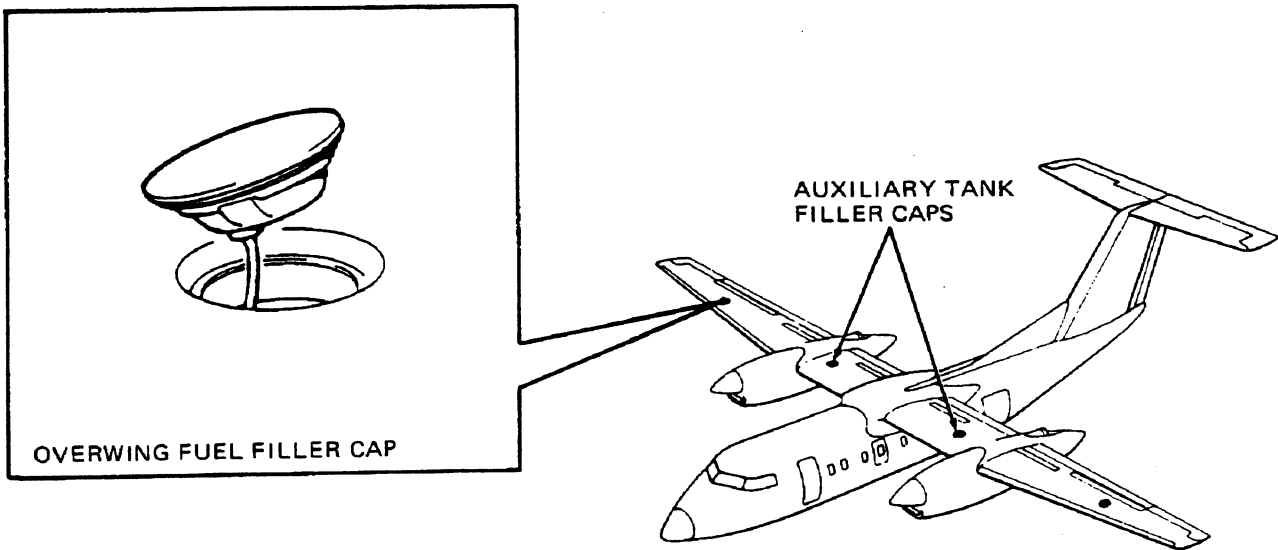

**CAUTION:**

BEFORE PERFORMING ANY REFUELING/DEFUELING OPERATIONS ENSURE THAT BOTH THE AIRCRAFT AND THE FUEL TENDER ARE GROUNDED.

BEFORE INSERTING FUELING NOZZLE IN TANK AT OVERWING FILLING POINT, GROUND THE NOZZLE TO ADJACENT GROUNDING SOCKET.

FUEL TANK	CAPS, ONE FOR EACH TANK, LOCATED ON WING UPPER SURFACE
FILLER CAP	GABB
FILLER NECK	OPENING COMPATIBLE WITH ANY STANDARD 3-INCH (7.62 CM) NOZZLE
GROUNDED PROVISIONS	AIRCRAFT CONNECTOR – MS90298-1 MATING GROUND CONNECTOR – MS3493

**GRAVITY REFUELING/DEFUELING**

**FIGURE 4 (SHEET 1)**

**2-30-04**

### DASH 8 AIRCRAFT RECOVERY

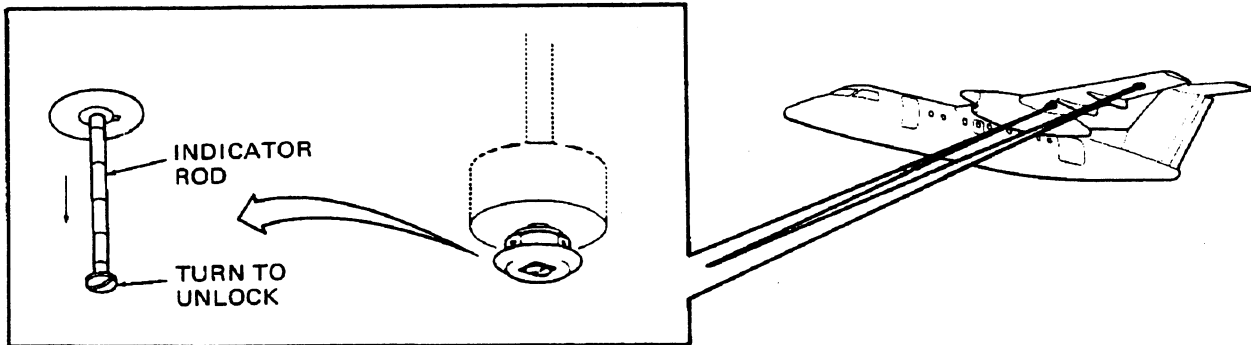

**MAGNETIC DIPSTICK**

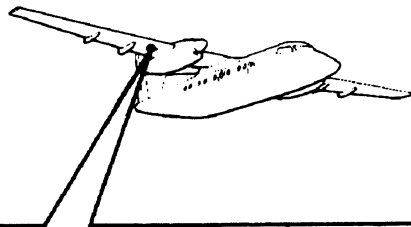

TWO MAGNETIC DIPSTICKS, 'MAGNA-STICK' ARE PROVIDED IN THE UNDERWING SURFACE OF EACH FUEL TANK AS ALTERNATIVE FUEL MEASURING DEVICES. AN EXTRA 'MAGNA-STICK' IS INSTALLED IN EACH UNDERWING SURFACE BETWEEN NACELLE AND FUSELAGE WHEN AUXILIARY TANKS ARE INSTALLED.

WHEN REQUIRED FOR MANUALLY MEASURING FUEL CONTENTS RELEASE INDICATOR ROD AND ALLOW ROD TO FALL SLOWLY UNTIL STOPPED BY INTERNAL FLOAT. READ FUEL CONTENTS FROM MARKINGS ON INDICATOR ROD.

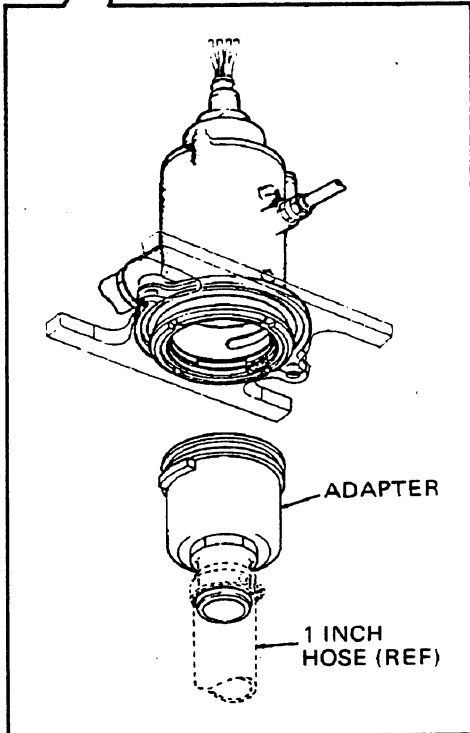

FUEL TANKS CAN BE EMPTIED MANUALLY BY REMOVING APPLICABLE AUXILIARY FUEL BOOST PUMP AND INSERTING ADAPTER.

DEFUELING ADAPTER RD53165-1  
(LEAR SIEGLER)

**GRAVITY DEFUELING  
AT AUXILIARY FUEL  
BOOST PUMP**

**GRAVITY REFUELING/DEFUELING  
FIGURE 4 (SHEET 2)**

# 2-30-04

**Boeing Canada**  
de Havilland Division  
**DASH 8 AIRCRAFT RECOVERY**

**POWER PLANT**

**1. General**

The aircraft is powered by two Pratt and Whitney PW120-A Turboprop engines driving Hamilton Standard 14SF-7 four bladed, constant speed variable and reversible pitch propellers.

**2. Removal (Figure 1 and 2)**

- A. Remove propellers using procedure in Aircraft Maintenance Manual PSM 1-8-2 or PSM 1-83-2.
- B. Remove engines using procedure in Aircraft Maintenance Manual PSM 1-8-2 or PSM 1-83-2.

**2-30-05**

PAGE 1

OCT 10/90

**Boeing Canada**  
de Havilland Division  
**DASH 8 AIRCRAFT RECOVERY**

**PURPOSE**

The propeller sling is used to handle the propeller when being removed from or installed on an engine.

**DESCRIPTION**

The sling is a welded steel assembly and weighs 11 lbs.

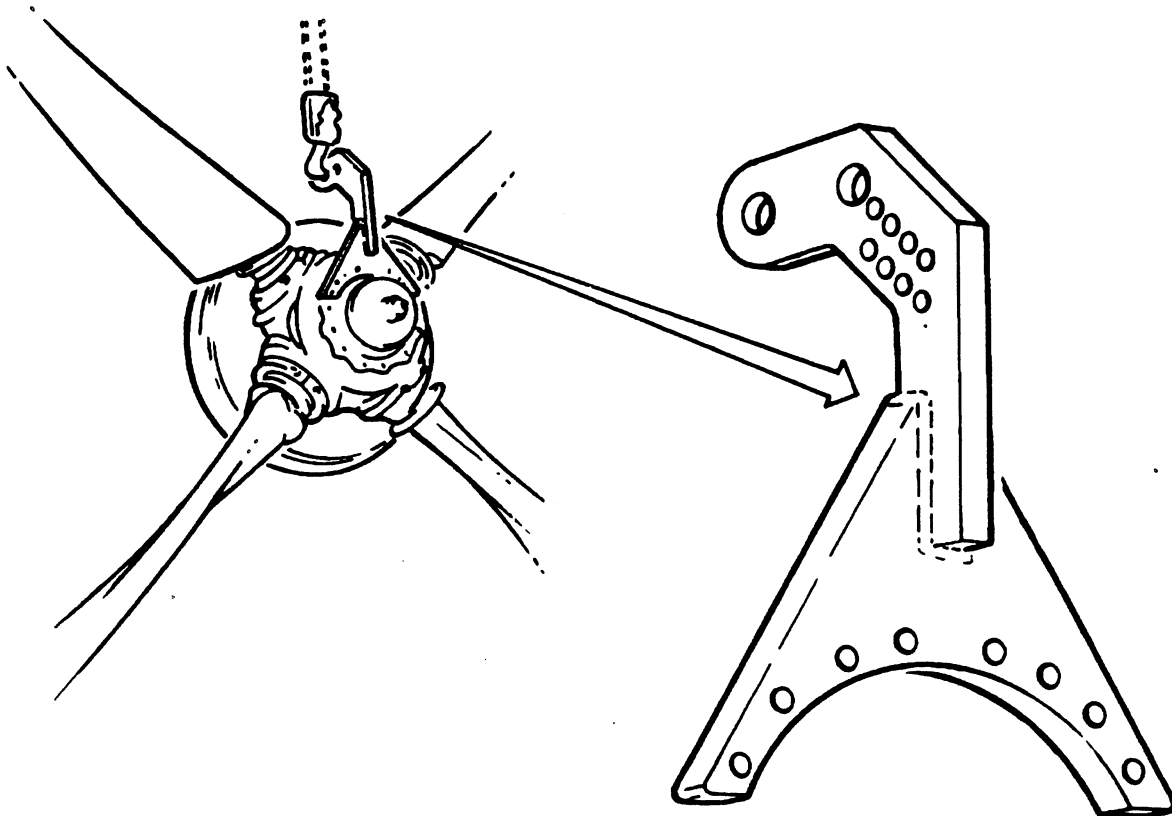

08-8009-4000  
PROPELLER SLING

**PROPELLER SLING**  
**FIGURE 1**

**2-30-05**

PAGE 2

OCT 10/90

**Boeing Canada**  
de Havilland Division  
**DASH 8 AIRCRAFT RECOVERY**

**PURPOSE**

The propeller transport and build stand is used to support, transport and build two propellers.

**DESCRIPTION**

The stand is constructed of tubular welded construction and can be dismantled for shipping and storage. A storage box is included for the propeller beta shafts.

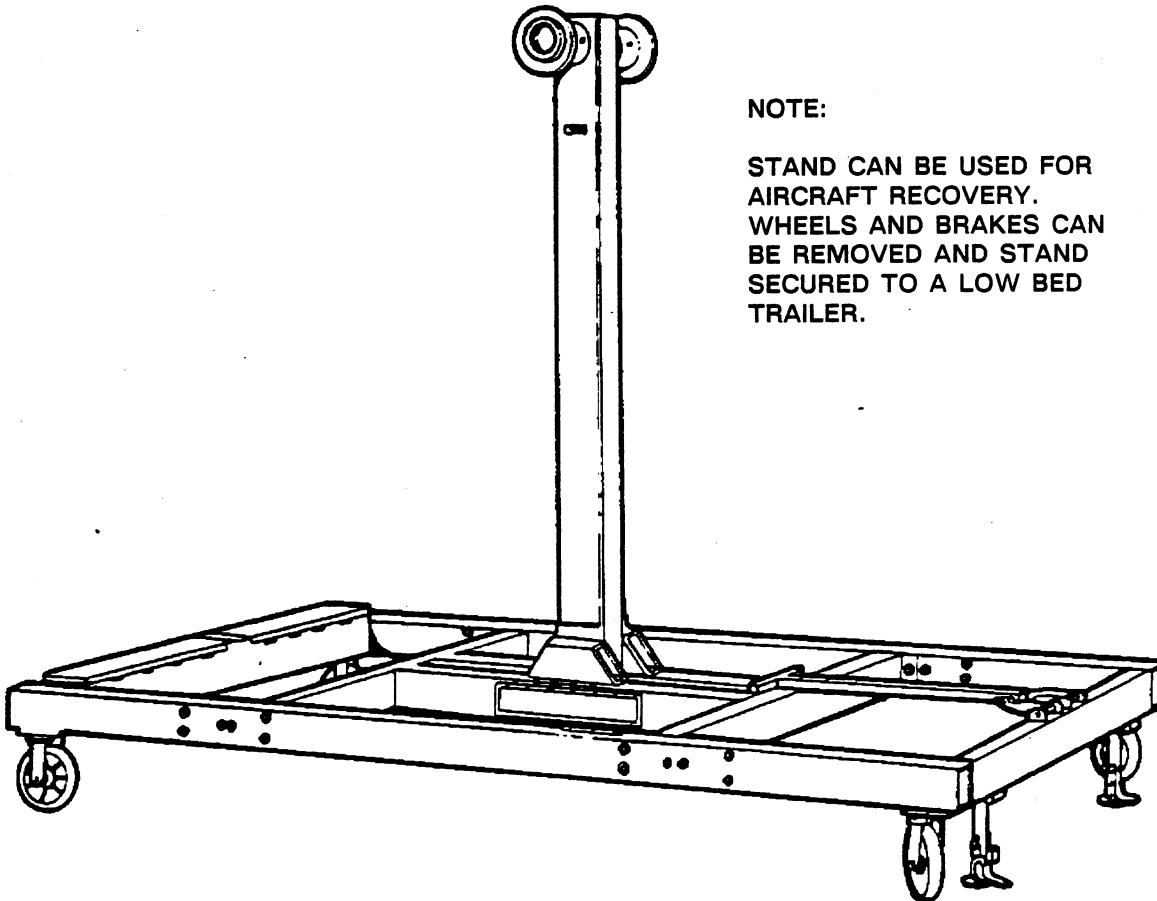

**NOTE:**

**STAND CAN BE USED FOR  
AIRCRAFT RECOVERY.  
WHEELS AND BRAKES CAN  
BE REMOVED AND STAND  
SECURED TO A LOW BED  
TRAILER.**

08-8044-0000  
PROPELLER TRANSPORT AND BUILD STAND

**PROPELLER TRANSPORT AND BUILD STAND  
FIGURE 2**

**2-30-05**

Boeing Canada  
de Havilland Division  
**DASH 8 AIRCRAFT RECOVERY**

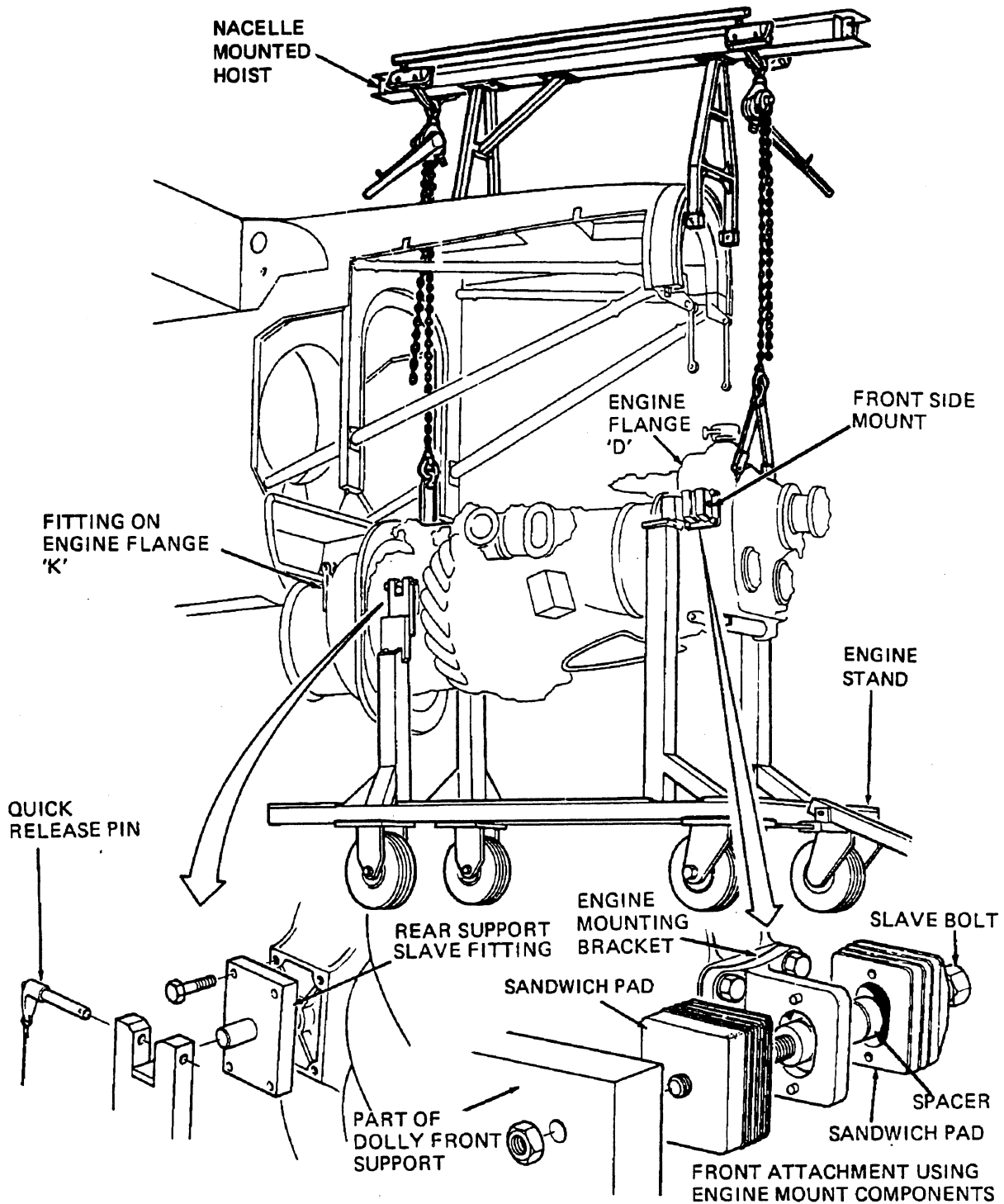

**BUILT-UP ENGINE POSITIONING AND SLINGING**

**FIGURE 3 (SHEET 1)**

**2-30-05**

DASH 8 AIRCRAFT RECOVERY

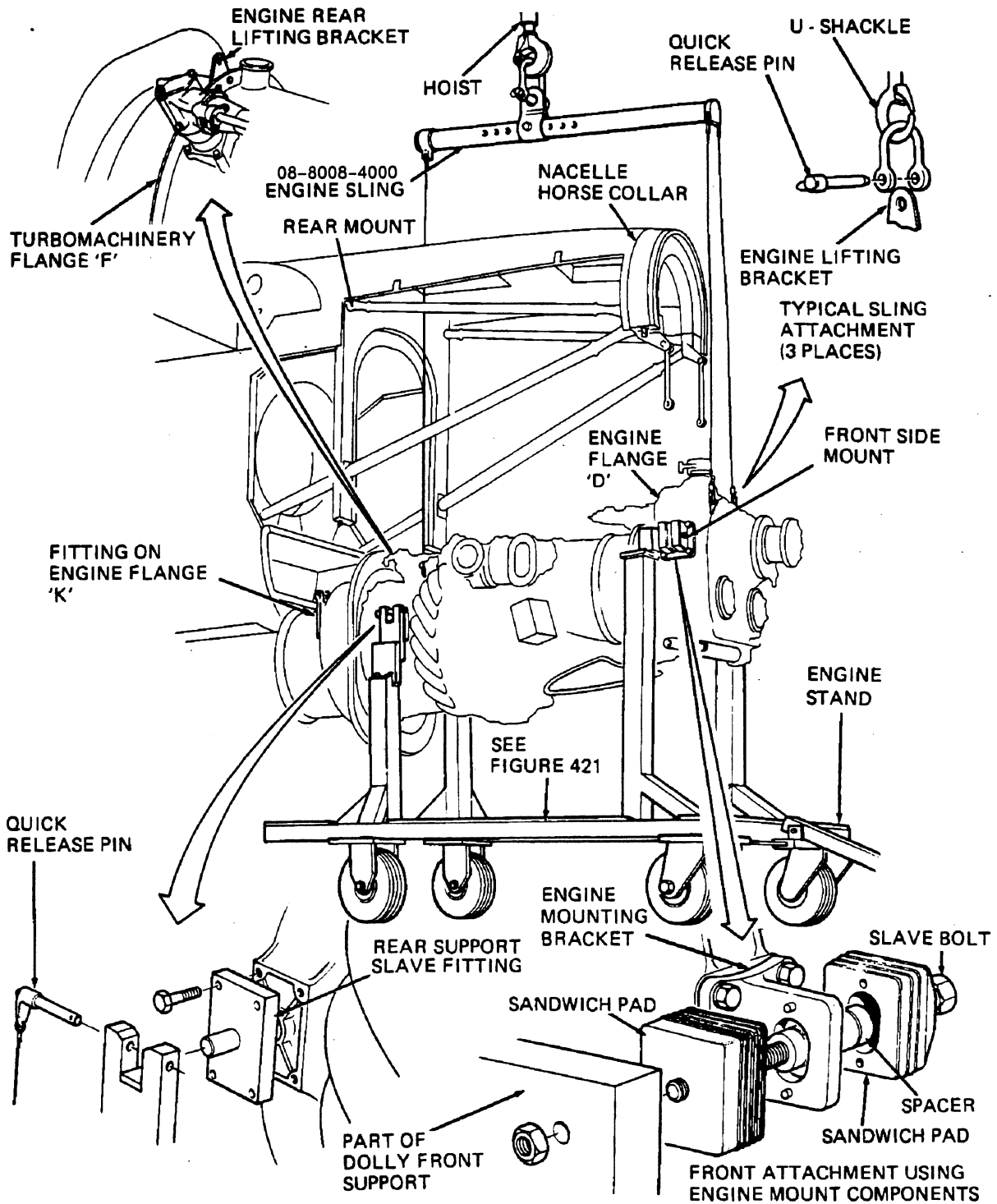

BUILT-UP ENGINE POSITIONING AND SLINGING

FIGURE 3 (SHEET 2)

2-30-05

**Boeing Canada**  
de Havilland Division  
**DASH 8 AIRCRAFT RECOVERY**

**THIS PAGE INTENTIONALLY LEFT BLANK**

**2-30-05**

PAGE 6

OCT 10/90



**Boeing Canada**  
de Havilland Division

**DASH 8 AIRCRAFT RECOVERY**

**LIST OF EFFECTIVE PAGES: CHAPTER 3: STABILIZE AIRCRAFT**

<b>Reference</b>	<b>Page</b>	<b>Date</b>	<b>Reference</b>	<b>Page</b>	<b>Date</b>
Contents	1	Oct 10/90	3-20-03	1	Oct 10/90
	2	Oct 10/90		2	Oct 10/90
3-00-00	1	Oct 10/90		3	Oct 10/90
	2	Blank		4	Oct 10/90
3-10-00	1	Oct 10/90		5	Oct 10/90
	2	Oct 10/90		6	Oct 10/90
	3	Oct 10/90		7	Oct 10/90
	4	Oct 10/90		8	Oct 10/90
	5	Oct 10/90	3-20-04	1	Oct 10/90
	6	Oct 10/90		2	Oct 10/90
	7	Oct 10/90		3	Oct 10/90
	8	Oct 10/90		4	Oct 10/90
3-10-01	1	Oct 10/90		5	Oct 10/90
	2	Oct 10/90		6	Oct 10/90
3-20-00	1	Oct 10/90		7	Oct 10/90
	2	Oct 10/90		8	Oct 10/90
3-20-01	1	Oct 10/90	3-20-05	1	Oct 10/90
	2	Oct 10/90		2	Oct 10/90
	3	Oct 10/90		3	Oct 10/90
	4	Oct 10/90		4	Oct 10/90
	5	Oct 10/90		5	Oct 10/90
	6	Oct 10/90		6	Blank
	7	Oct 10/90			
	8	Blank			
3-20-02	1	Oct 10/90			
	2	Oct 10/90			
	3	Oct 10/90			
	4	Oct 10/90			
	5	Oct 10/90			
	6	Blank			

The asterisk (\*) indicates pages revised, added or deleted by current revision.

**3 - EFFECTIVE PAGES**

**Boeing Canada**  
de Havilland Division  
**DASH 8 AIRCRAFT RECOVERY**

**THIS PAGE INTENTIONALLY LEFT BLANK**

**3 – EFFECTIVE PAGES**

PAGE 2

OCT 10/90

## DASH 8 AIRCRAFT RECOVERY

### CHAPTER 3 - STABILIZE AIRCRAFT

#### TABLE OF CONTENTS

Subject	Chapter Section Subject	Page
<b>STABILIZE AIRCRAFT</b>	<b>3-00-00</b>	
General		1
<b>TETHERING</b>	<b>3-10-00</b>	
General		1
Tethering Lines		
<b>GROUND ANCHORS</b>	<b>3-10-01</b>	
General		1
Types of Anchors		
<b>LIFTING DAMAGED AIRCRAFT</b>	<b>3-20-00</b>	
General		1
Basic Preparation of Lifting		2
<b>JACKING AIRCRAFT</b>	<b>3-20-01</b>	
General		1
Preparation for Using Jacks		
Jacking Complete Aircraft		2
Jacking Unlevel Aircraft		
Jacking at Landing Gear		3
<b>PNEUMATIC BAGS</b>	<b>3-20-02</b>	
General		1
Preparation for Using Pneumatic Bags		2
Lifting with Pneumatic Bags		
<b>LIFTING AIRCRAFT WITH MOBILE CRANE</b>	<b>3-20-03</b>	
General		1
Preparation for Using Mobile Crane		
Foreward Fuselage		2
Three Point Lift Method		
Lifting Sling Requirements		6
<b>LIFTING</b>	<b>3-20-04</b>	
Nose Gear Collapsed		1
Main Gear Collapsed		
Main Gear Collapsed One Side		2
Nose Gear and One Main Gear Collapsed		
Main and Nose Landing Gears Collapsed		3

## 3-CONTENTS

**Boeing Canada**  
de Havilland Division

**DASH 8 AIRCRAFT RECOVERY**

**CHAPTER 3 - STABILIZE AIRCRAFT**

**TABLE OF CONTENTS(Cont'd)**

<b>Subject</b>	<b>Chapter Section Subject</b>	<b>Page</b>
<b>LIFTING MATERIALS AND ATTACHMENTS</b>	<b>3-20-05</b>	
Straps		1
Manila Rope (Abaca)		3
Chains		
Wire Rope		

**3-CONTENTS**

PAGE 2

OCT 10/90

**Boeing Canada**  
de Havilland Division  
**DASH 8 AIRCRAFT RECOVERY**

**STABILIZE AIRCRAFT**

**Aircraft General**

This chapter encompasses methods and devices for stabilizing and lifting the aircraft. Protection of the aircraft from additional damage is of immediate concern, protect it from the weather by closing doors and access panels.

**3-00-00**

PAGE 1

OCT 10/90

**Boeing Canada**  
de Havilland Division  
**DASH 8 AIRCRAFT RECOVERY**

**THIS PAGE INTENTIONALLY LEFT BLANK**

**3-00-00**

**PAGE 2**

**OCT 10/90**

**Boeing Canada**  
de Havilland Division  
**DASH 8 AIRCRAFT RECOVERY**

**TETHERING**

**1. General**

- A. Tethering requirements arise from the need for restraint against horizontal loads imposed on the aircraft, during the lifting phase of the recovery operation. These horizontal loads are a result of either the lifting equipment or winds.
- B. Whether or not the aircraft must be tethered to insure a safe recovery is dependent upon the type of aircraft incident, recovery method, equipment used, terrain and wind conditions.

**NOTE: It is recommended that tethering requirements be determined at the site of the incident by planners who have practical field recovery experience.**

- C. Information is provided regarding size and type of restraint cables and ground anchors. See Figure 1 and refer to 3-10-01 Ground Anchor.

**2. Tethering Lines**

- A. The number and orientation of the tethering lines required to hold the aircraft steady should be determined by the recovery captain to insure a stable condition of the aircraft.

**NOTE: A restraining line installed on one side of the aircraft. Must have a counterpart on the opposite side of aircraft.**

- B. Each tethering line must have some means of adjustment to allow for changes in cable length requirement. A positive load must be applied at all times to keep the cables taut and prevent swaying. Install a dynamometer on each line, and assign one lineman for each tether line to monitor the dynamometer as the aircraft is being raised to ensure that excessive force is not transmitted to the aircraft attach fitting. The tensioning device must be released to ease the load.

**WARNING: DURING WET WEATHER OPERATIONS, MANILA LINES WILL SHRINK. DURING SUCH TIMES, CARE MUST BE USED TO ENSURE THAT LINES DO NOT BECOME OVERLOADED AND OVERSTRESS THE AIRCRAFT STRUCTURE. WET MANILA LINES MAY ALSO FREEZE AND WHEN IN THIS CONDITION MAY BE READILY BROKEN.**

**NOTE: Using a factor of safety greater than five, based on the breaking strength of the line, is recommended.**

**3-10-00**

PAGE 1

OCT 10/90

## **DASH 8 AIRCRAFT RECOVERY**

- C. Exercise care in the selection and rigging of tethering lines. In rigging rope lines, an eye splice over a thimble in the end of the line can produce approximately 90% of the breaking strength of the rope as compared to approximately 60% where the end is knotted. All lines must be protected from sharp edges by padding.

**CAUTION: INSPECT ALL LINES TO ENSURE THEIR SAFETY: CHECK FOR WEAR, ABRASION, RUST AND CUT OR BROKEN STRANDS. IF FIBER TYPE ROPES ARE USED, TWIST THE STRANDS OPEN AND EXAMINE FOR DEGRADATION OR BROKEN STRANDS. BADLY KINKED STEEL CABLES SHOULD NOT BE USED.**

**3-10-00**

PAGE 2

OCT 10/90



**DASH 8 AIRCRAFT RECOVERY**

TETHERING LINE MINIMUM BREAKING STRENGTH							
NOMMAL DIAMETER	(ABACA) MANILA FED. SPEC. TR 605	DUPONT DACRON	NYLON	DOUBLE NYLON BRAID	STEEL CABLE (6X19 WITH FIBRE CORE)		
						SMALLER DIAMETERS	
1/2 (1.27)	2,650 (1,202)	6,100 (2,767)	6,650 (3,016)	7,500 (3,402)	21,400 (9,707)	3/16 (.48)	3,100 (1,406)
5/8 (1.58)	4,400 (1,996)	9,500 (4,309)	10,000 (4,536)	12,000 (5,443)	33,400 (15,150)	1/4 (.64)	5,480 (2,486)
3/4 (1.91)	5,400 (2,449)	13,200 (5,988)	14,600 (6,623)	17,000 (7,711)	47,600 (21,591)	5/16 (.79)	8,520 (3,865)
7/8 (2.22)	7,700 (3,493)	17,500 (7,938)	19,600 (8,891)	23,700 (10,750)	64,400 (29,212)	3/8 (.925)	12,200 (5,534)
1 (2.54)	9,000 (4,082)	22,000 (9,979)	25,000 (11,340)	28,500 (12,928)	83,600 (37,921)	7/16 (1.11)	16,540 (7,503)
1 1/4 (3.175)	13,500 (6,124)	30,500 (13,835)	37,800 (17,146)	44,000 (19,958)	129,200 (58,605)		

- NOTE: 1. SAFE WORKING LOAD TO BREAKING STRENGTH SHOULD BE A 1 TO 5 RATIO  
2. SEE FIGURE 2 FOR ATTACHING WIRE ROPE CLIPS

DIAMETERS ARE IN INCHES (CM)  
BREAKING STRENGTH IS IN POUNDS (KG)

**TETHERING LINE MATERIALS**

**FIGURE 1**

**3-10-00**

**DASH 8 AIRCRAFT RECOVERY**

**METHOD OF ATTACHING WIRE ROPE CLIPS**

**RIGHT WAY**



THIS ILLUSTRATES THE CORRECT APPLICATION OF WIRE CLIPS. ALL THE SADDLES OF THE CLIPS ARE IN CONTACT WITH THE LOAD END OF THE ROPE AND THE CLIPS ARE CORRECTLY SPACED.

**WRONG WAY**



THIS ILLUSTRATES THE INCORRECT APPLICATION OF WIRE ROPE CLIPS. THE CLIPS ARE TOO CLOSE TOGETHER AND CLIPS NOS. 1 AND 3 HAVE THE U BOLTS IN CONTACT WITH THE LOAD END OF THE ROPE.

**EFFICIENCY WITH USE OF CLIPS**

THE CORRECT NUMBER OF CLIPS PROPERLY ATTACHED, WILL DEVELOP AN EFFICIENCY BETWEEN 75% AND 85% OF THE ROPE BREAKING STRENGTH. THE DISTANCE BETWEEN CLIPS SHOULD NOT BE LESS THAN SIX TIMES THE DIAMETER OF THE WIRE ROPE. AFTER ROPE HAS BEEN IN USE A SHORT TIME, ALL CLIPS SHOULD BE TIGHTENED AGAIN.

DIAMETER OF ROPE (INCHES)	NUMBER OF CLIPS	SPACE IN INCHES BETWEEN CLIPS
1/4	2	1-1/2
5/16	2	1-7/8
3/8	2	2-1/4
7/16	2	2-5/8
1/2	3	3
9/16	3	3-3/8
5/8	3	3-3/4
3/4	4	4-1/2
7/8	4	5-1/4
1	4	6
1-1/8	5	6-3/4
1-1/4	5	7-1/2

**ATTACHING WIRE ROPE CLIPS**  
**FIGURE 2**

**3-10-00**

**DASH 8 AIRCRAFT RECOVERY**

MATL: SCREW PIN – DROP FORGED STEEL

NOTES:

1. SAFE WORKING LOAD TO BREAKING STRENGTH SHOULD BE A 1 TO 5 RATIO.
2. SHACKLES CAN BE THE SAME SIZE AS THE ROPE BUT ONE SIZE LARGER IS PREFERABLE.
3. DIMENSIONS – INCHES (CENTIMETERS)  
STRENGTH – TONS (METRIC TONS)

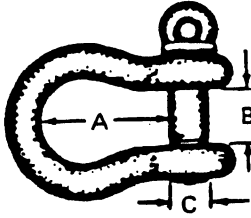

SIZE	ULTIMATE STRENGTH	DIMENSIONS		
		A	B	C
3/8 (0.953)	4.0 (3.628)	1 1/2 (3.81)	11/16 (1.75)	7/16 (1.11)
1/2 (1.27)	7.0 (6.349)	2 (5.08)	7/8 (2.22)	5/8 (1.59)
5/8 (1.59)	11.0 (9.977)	2-3/8 (6.03)	1-1/16 (2.7)	3/4 (1.91)
3/4 (1.91)	15.9 (14.42)	2-7/8 (7.30)	1-1/4 (3.175)	7/8 (2.22)
7/8 (2.22)	21.6 (19.59)	3-1/4 (8.255)	1-3/8 (3.49)	1 (2.54)
1 (2.54)	28.3 (25.668)	3-5/8 (9.21)	1-11/16 (4.29)	1-1/8 (2.86)
1-1/8 (2.86)	33.4 (30.294)	4-1/4 (10.8)	1-7/8 (4.76)	1-1/4 (3.175)
1-1/4 (3.175)	41.2 (37.368)	4-3/4 (12.065)	2 (5.08)	1-3/8 (3.49)
1-3/8 (3.49)	49.9 (45.259)	5-1/4 (13.335)	2-1/8 (5.44)	1-1/2 (3.81)
1-1/2 (3.81)	59.3 (53.785)	5-1/2 (13.97)	2-1/4 (5.715)	1-5/8 (4.13)

**ANCHOR SHACKLES**

**FIGURE 3**

**3-10-00**

**Boeing Canada**  
de Havilland Division

**DASH 8 AIRCRAFT RECOVERY**

SHACKLE SIZE		A	B	C	D	E	F	WEIGHT LBS EACH	SAFE WORKING LOAD TONS
INCHES	M M								
1/2	13	1-7/8	13/16	1-5/16	5/8	1-3/16	1/2	0.79	2
5/8	16	2-3/8	11/16	1-11/16	3/4	1-9/16	5/8	1.60	3-1/4
3/4	19	2-13/16	1-1/4	2	7/8	1-7/8	3/4	2.72	4-3/4
7/8	22	3-5/16	1-7/16	2-9/32	1	2-1/8	7/8	3.95	6-1/2
1	25	3-3/4	1-11/16	2-11/16	1-1/8	2-3/8	1	6.12	8-1/2
1-1/8	29	4-1/4	1-13/16	2-29/32	1-1/4	2-5/8	1-1/8	8.27	9-1/2
1-1/4	32	4-11/16	2-1/32	3-1/4	1-3/8	3	1-1/4	11.71	12
1-3/8	34	5-1/4	2-1/4	3-5/8	1-1/2	3-5/16	1-3/8	15.83	13-1/2
1-1/2	38	5-3/4	2-3/8	3-7/8	1-5/8	3-5/8	1-1/2	20.80	17
1-3/4	44	7	2-7/8	5	2	4-5/16	1-3/4	33.91	25
2	51	7-3/4	3-1/4	5-3/4	2-1/4	5	2	51.75	35
2-1/2	64	10-1/2	4-1/8	7-1/4	2-3/4	6	2-1/2	101.59	55
3	76	13	5	7-7/8	3-1/4	6-1/2	3	178.00	85

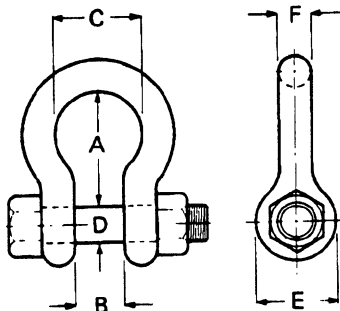

BOLT TYPE SHACKLES  
SHOULD MEET OR EXCEED  
FEDERAL SPECIFICATION  
RR-C27 1b

ROPE DIA. (INCHES)	A	B	C	D	E	F	G	H	WT. PER 100
1/4	2.19	1.63	1.50	0.88	0.41	0.28	0.06	0.23	7.5
5/16	2.50	1.88	1.81	1.06	0.50	0.34	0.08	0.28	14.00
3/8	2.88	2.13	2.13	1.13	0.63	0.41	0.11	0.34	25.00
7/16	3.25	2.38	2.38	1.25	0.72	0.47	0.13	0.38	36.00
1/2	3.63	2.75	2.75	1.50	0.81	0.53	0.14	0.41	51.00
9/16	3.63	2.75	2.69	1.50	0.88	0.59	0.14	0.41	51.00
5/8	4.25	3.25	3.13	1.75	0.97	0.66	0.16	0.50	75.00
3/4	5.00	3.75	3.81	2.00	1.22	0.78	0.22	0.66	147.0
7/8	5.50	4.25	4.25	2.25	1.38	0.94	0.22	0.75	185.0
1	6.13	4.50	4.94	2.50	1.56	1.06	0.25	0.88	291.66
1-1/8 - 1-1/4	7.00	5.13	5.88	2.88	1.81	1.31	0.25	1.13	383.33
1-1/4 - 1-3/8	9.06	6.50	6.81	3.50	2.19	1.44	0.38	1.13	816.66
1-3/8 - 1-1/2	9.00	6.25	7.13	3.50	2.56	1.56	0.50	1.13	1,166.66
1-5/8	11.25	8.00	8.13	4.00	2.72	1.72	0.50	1.38	1,625.00
1-3/4	12.19	9.00	8.50	4.50	2.84	1.84	0.50	1.31	1,837.50
1-7/8 - 2	15.13	12.00	10.38	6.00	3.09	2.09	0.50	1.50	2,575.00
2-1/4	17.13	14.00	11.88	7.00	3.63	2.38	0.63	1.63	4,300.00

**BOLT TYPE SHACKLES AND THIMBLES**  
**FIGURE 4**

**3-10-00**



## DASH 8 AIRCRAFT RECOVERY

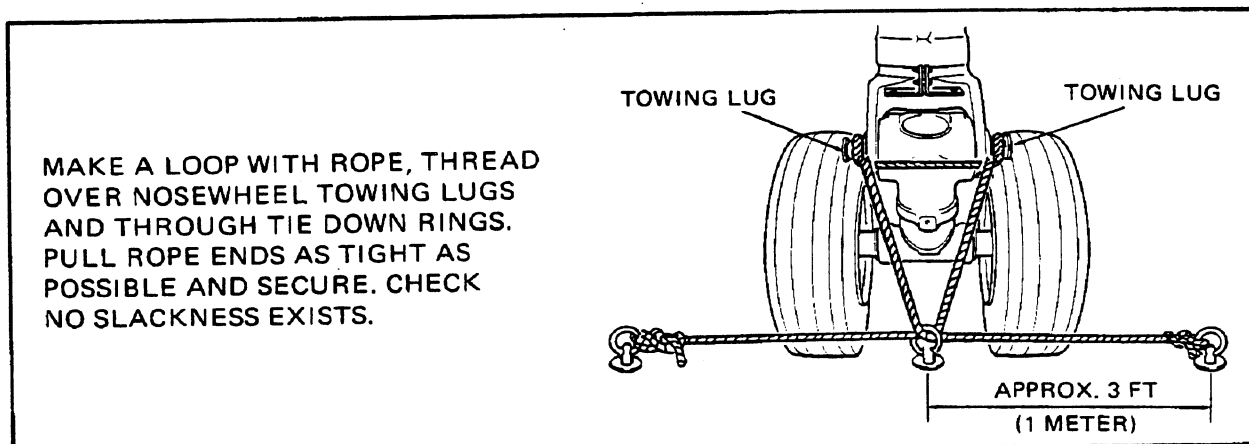

### NOSE GEAR TIE-DOWN

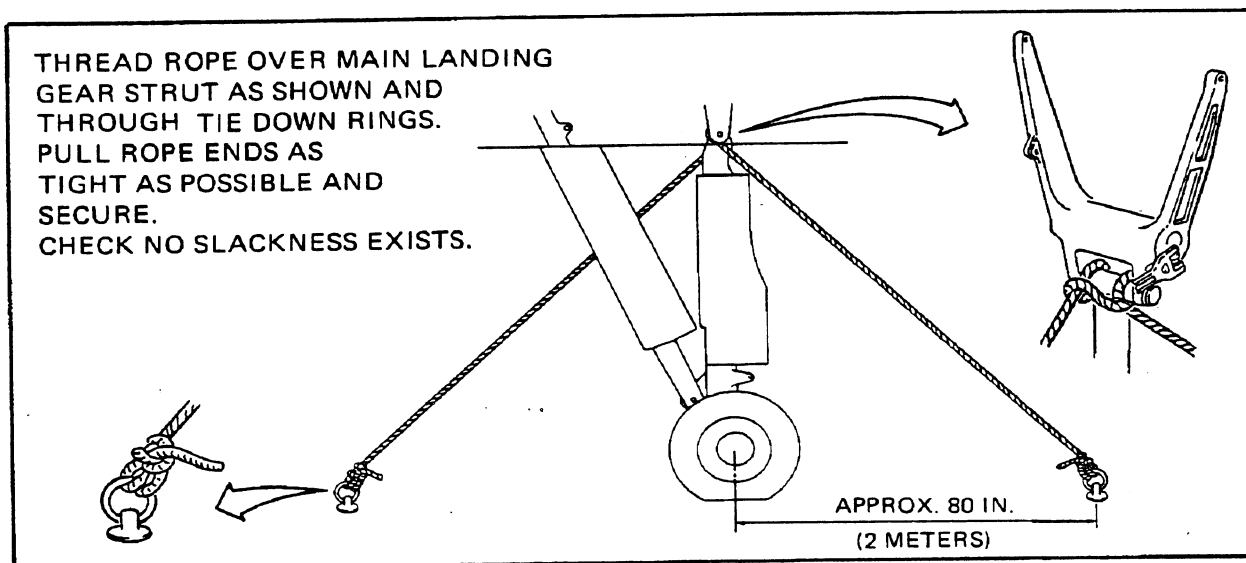

### MAIN GEAR TIE-DOWN

IF AIRCRAFT IS TO BE PARKED FOR AN EXTENDED PERIOD OF TIME IN EXTREME HIGH WIND CONDITIONS, TIE DOWN LINES MAY BE SAFELY ATTACHED AT THE FOLLOWING THREE POINTS:

- NOSE GEAR LEG AT TOWING LUGS.
- BOTH MAIN GEAR LEGS.

NOTE: SUITABLE WHEEL CHOCKS MUST BE PLACED IN FRONT OF AND BEHIND MAIN WHEELS WHEN AIRCRAFT IS TIED DOWN.

NYLON OR POLYPROPYLENE ROPES 0.75 INCH (19mm) IN DIAMETER ARE RECOMMENDED.

### AIRCRAFT TIE-DOWN ARRANGEMENTS

FIGURE 6

3-10-00

## **DASH 8 AIRCRAFT RECOVERY**

### **GROUND ANCHORS**

#### **1. General**

- A. Tethering lines are held steady by securing to heavy vehicles, buried timber (dead man), ground anchors or other structures.
- B. Various types of ground anchors are available for specific ground conditions.
- C. Install each anchor unit in accordance with the manufactures installation instructions.

#### **2. Types of Anchors**

- A. Ground anchors are manufactured from malleable iron, aluminum or steel, they vary in weight, size and holding power.
- B. Most types of ground anchors are utilized by being hand driven using a manual impact tool, driving rod and handle.
- C. Screw type anchors are set in place by means of a power driving machine.
- D. The expanding anchor type is set in place by first drilling a hole, the anchor is then pushed into the hole. By turning the anchor rod, the blades expand, digging into the soil, the clearance around the rod is then filled with tamped soil or fast setting concrete.
- E. Before attaching the tether line, preload anchor to take in any slack or settling.

**3-10-01**

PAGE 1

OCT 10/90

**Boeing Canada**  
de Havilland Division  
**DASH 8 AIRCRAFT RECOVERY**

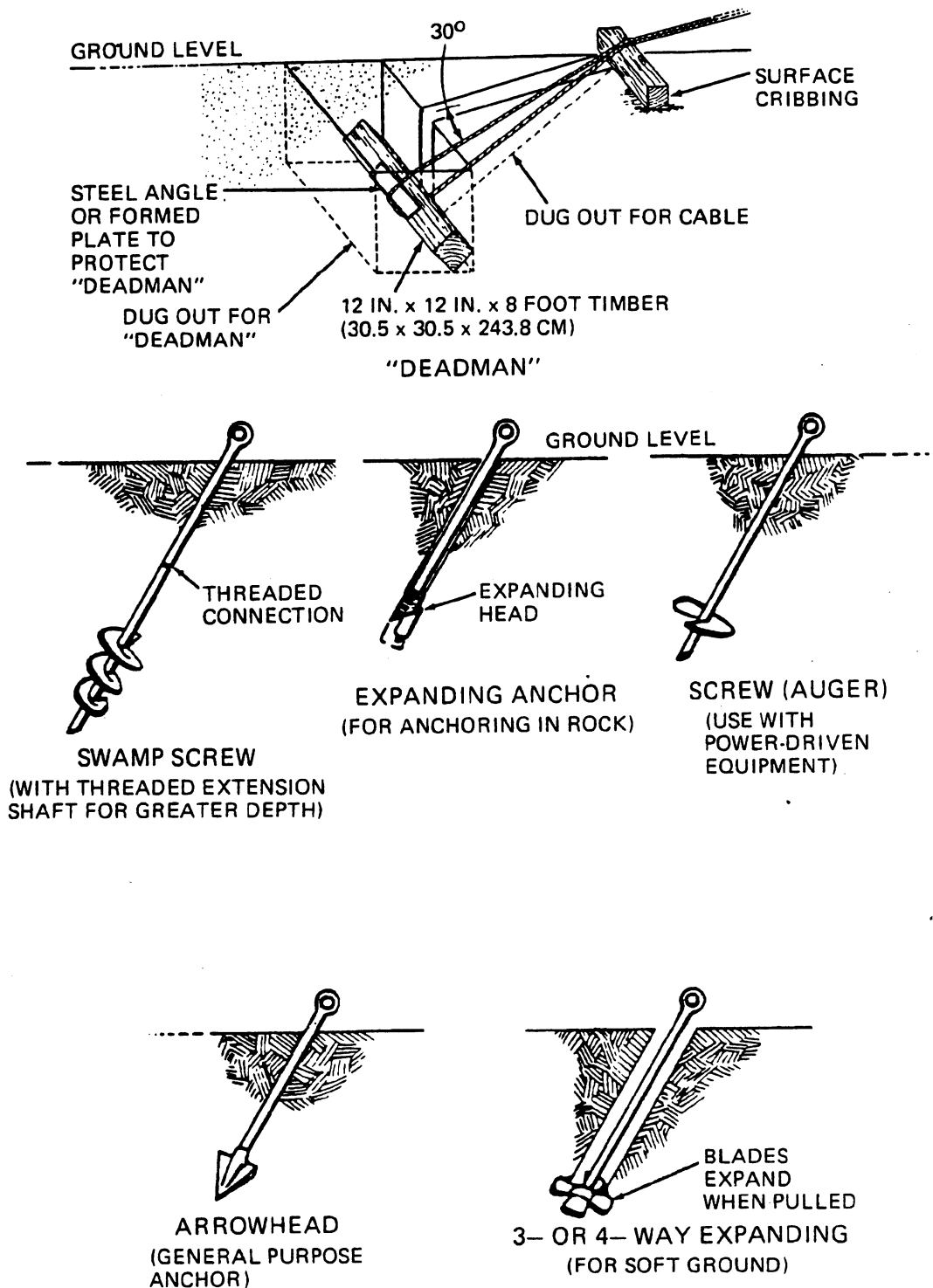

TYPICAL ANCHOR INSTALLATION

FIGURE 1

**3-10-01**



## **DASH 8 AIRCRAFT RECOVERY**

### **LIFTING DAMAGED AIRCRAFT**

#### **1. General**

- A. Practically every aircraft recovery is unique. Each situation must be analyzed with respect to the specific conditions.
- B. Jacks, pneumatic bags, cranes and slings have all proved their worth for lifting aircraft. While the time honored method for lifting an aircraft from the belly position is a series of air bags, extra care is required because of their instability. Often a simpler and safer method is the use of axle jacks and cribbing, for lifting in smaller increments. Cranes and slings should be considered if available, particularly for lifting the forward fuselage for replacing the nose gear.
- C. As outlined in Chapter 2, the aircraft weight should be reduced as much as possible to make the lift easier and safer. When only one wing is to be lifted, it may be advantageous to leave or transfer fuel to the opposite wing tanks. Ballast may also be required in the forward or aft cargo compartments to correct CG problems.

**WARNING: EXTREME CAUTION SHOULD BE OBSERVED WHEN MOVING THE AIRCRAFT OR CHANGING ITS ATTITUDE. FUEL SPILLS AND/OR VAPORS WHICH MAY BE RELEASED CAN CREATE A POTENTIALLY DANGEROUS SITUATION. PERSONNEL SHOULD MONITOR FOR THIS SITUATION AND CORRECTIVE ACTION SHOULD BE TAKEN IMMEDIATELY IF IT OCCURS.**

- D. The aircraft should be raised in a manner to keep the aircraft as horizontal as possible to reduce side loading of jack points and minimize shift of air bags. Levels and plumb bobs should be used to verify attitude during the lift. Once the aircraft is leveled the plumb bob should be watched during additional lifting to insure that no shifting occurs.
- E. Every consideration must be given to proper planning and procedures in order to eliminate or minimize hazards to personnel or the possibility of secondary damage to the aircraft during the lifting process.

**CAUTION: EXTREME CARE MUST BE TAKEN WHEN LIFTING OR JACKING AIRCRAFT IN WINDS OF 20 M.P.H. (32 KM PER HOUR) OR MORE.**

**WARNING: CAUTION SHALL BE USED WHEN LIFTING THE AIRCRAFT. DAMAGED STRUCTURE THAT HAS BEEN DEFORMED AND PRELOADED MAY BE PROPELLED AT HIGH SPEED BY THE SUDDEN RELEASE OF ENERGY DURING THE HOISTING OPERATION.**

**3-20-00**

## DASH 8 AIRCRAFT RECOVERY

### 2. Basic Preparations for Lifting

- A. Review Aircraft Recovery Plan in Chapter 2.
- B. Survey the terrain and inspect the structure in the lift point areas as soon as possible to determine their integrity (refer to chapter 2). Damaged areas and ground condition may affect the method of lifting.
- C. Landing gear down-locks should be installed as soon as possible on all gears in the extended position. This is a mandatory safety precaution.
- D. Determine locations of CG as outlined in Chapter 2. Complete defueling and removal of payload will result in an OEW condition and a CG location that should cause no problems. If substantial payload or fuel is still aboard or if a major component has been torn loose, then a Net Recoverable Weight (NRW) and CG location should be calculated. If the NRW is high and the CG moves too far forward or aft, then the resulting loads on the lift points must be determined to prevent overloading jack pads, skin surfaces, etc.

**NOTE: When final configuration, weight and CG are determined, mark both sides of fuselage where CG is located for ready reference.**

- E. Reduce weight to a minimum by removing payload and defueling as outlined in Chapter 2.
- F. Tethering must be completed prior to lift.
- G. Reduce air pressure in landing gear struts as required if gear is to be locked in the collapsed position.

## **DASH 8 AIRCRAFT RECOVERY**

### **JACKING AIRCRAFT**

#### **1. General (Figure 1)**

Three jacking points are provided for jacking the complete aircraft, located one on each wing rear spar and one in the nose. Individual jacking at each of the landing gear units, for wheel changing, is possible using jacking pads at the base of the main gear shock struts and on the nose gear suspension lever.

**NOTE: The supervisor of the recovery team or his designated replacement must be in control of the jacking operation and he alone will give the signals to the members of recovery crew.**

**NOTE: Jacking of aircraft should not be attempted in winds exceeding 20 M.P.H. (32 KM per hour)**

#### **2. Preparation for Using Jacks**

- A. In all probability during aircraft recovery, jacks will rest on terrain other than a hard surfaces area; therefore, the bearing strength of the jack base area must be determined. Should the consistency of the base area be such that the area will not support expected jack loading, preparations must be made to strengthen the area. Extremely soft terrain may require excavation and a crushed rock fill to provide the necessary bearing strength (Figure 4).
- B. The area at the base of the jack must be flat and level in order for the jack to be vertical.
- C. Install jack pads.
- D. Compress jacks to minimum height.
- E. Double check that necessary cribbing, jacks, etc., are present and tethering is complete. All lifting functions should be initially directed toward leveling the aircraft. The attitude can be monitored by using a plumb bob as outlined in Maintenance Manual PSM 1-8-2 or PSM 1-83-2 Chapter 8. A carpenters level can also be used in place of the plumb bob by placing it on the floor of the aircraft or plumb bobs can be taped to the outside body pointing to flat plates on ground.
- F. Prior to jacking, review the procedures and overall plan with recovery crew members so that each member understands and will anticipate problems affecting the safety of personnel or aircraft.

**3-20-01**

PAGE 1

OCT 10/90

## DASH 8 AIRCRAFT RECOVERY

### 3. Jacking Complete Aircraft (Figure 1)

**CAUTION: THE MAXIMUM AIRCRAFT WEIGHT FOR JACKING THE COMPLETE AIRCRAFT IS MAXIMUM RAMP/TAXI WEIGHT:**

MODEL 101	33,200 lb	15,060 Kg
MODEL 102	34,700 lb	15,740 Kg

Equipment required:

3 Jacking Adapters	02-8014-4000	(Tronair)
2 Wing Lifting Jacks	02-8002-0100	(Tronair)
1 Nose Lifting Jack	02-8003-0132	(Tronair)
1 Tail Stand	03-8016-000	(Tronair)

**NOTE: Supervisor of the recovery team or designated replacement shall be in control of the jacking operation and he alone will give the signals to all members of the recovery team. Five other members of the team are required, one for each lifting jack, one at wing jack to hold jacking adapter in position until jack makes contact then to adjust the tethering lines.**

- A. Raise aircraft in a conventional jacking manner until the planned height is reached to either lower collapsed landing gear, replace gear or place a flat bed trailer underneath for moving aircraft, refer to Maintenance Manual PSM 1-8-2 or PSM 1-83-2 Chapter 7 for normal jacking procedures.

**CAUTION: INSTALL GROUND LOCK PINS IN LOWERED LANDING GEAR AS SOON AS POSSIBLE AFTER LOWERING.**

**NOTE: When aircraft is on Jacks use Tail Stand (Figure 3) to stabilize if possible.**

- B. When aircraft is level, any additional lifting should be done in a manner to maintain level attitude. Uneven attitudes will place unpredictable side loads on jacks. The plumb bob hung previously must be checked frequently to warn of any shifting of aircraft.
- C. Since there are no alternate jack points on the wing some other means are required to hold the aircraft in its partially lifted position while jacks are readjusted and additional cribbing is moved under jack position.

### 4. Jacking Uneven Aircraft

If aircraft is not level raise the low point first. Due to the rotation effect, the low jack point will move in an arc during the lift. Inward movements can be 10 to 15 inches for the worst case. This movement can cause excessive side loads on jacks. Therefore, small increments of about 6 to 8 inches vertical lifts should be made, and the wing or fuselage near the jack point supported by cribbing to hold the airplane in this partially lifted position while jack(s) are realigned and additional cribbing is moved under jack(s). Repeat this lift-crib-lift method until aircraft is level.

**NOTE: It may be advantageous to deflate oleos and tires of any supporting gear to reach a level attitude sooner.**

**3-20-01**

## **DASH 8 AIRCRAFT RECOVERY**

**CAUTION: WHILE LEVELING AIRCRAFT, THE C.G. CAN SHIFT SUBSTANTIALLY IF FUEL TANKS ARE PARTIALLY FULL.**

### **5. Jacking at Landing Gear (Figure 2)**

**CAUTION: THE MAXIMUM AIRCRAFT WEIGHT FOR JACKING AT NOSE AND MAIN LANDING GEAR POINTS IS MAXIMUM RAMP/TAXI WEIGHT:**

MODEL 101	33,200 lb	15,060 Kg
MODEL 102	34,700 lb	15,740 Kg

Equipment required:

1 Axle Jack 02-8007-0133 (Tronair)  
Ball Lock Pin NAS 1354-DC5C-20D

A. For jacking procedures refer to Maintenance Manual PSM 1-8-2 or PSM 1-83-2 Chapter 7.

- (1) Apply parking brake.
- (2) Install ground locks on main landing gear and apply nose gear ground lock if possible.
- (3) If the nose landing gear unit is to be jacked, proceed as follows:
  - (a) Center the nosewheels.
  - (b) Engage castor lock and secure with ball lock pin.
- (4) Position jack under main or nose jacking pad as required.
- (5) Chock wheels at other two landing gear units.
- (6) Raise jack until wheels are 1 to 2 inches (2.5 to 5.1 cm) clear of ground.
- (7) On completion of operation, lower jack and remove from vicinity of aircraft.
- (8) Remove ball lock pin, if installed, from nose gear castor lock and check that castor lock disengages.

**3-20-01**

PAGE 3

OCT 10/90

**DASH 8 AIRCRAFT RECOVERY**

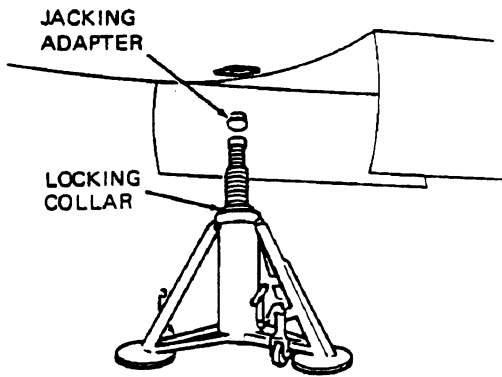
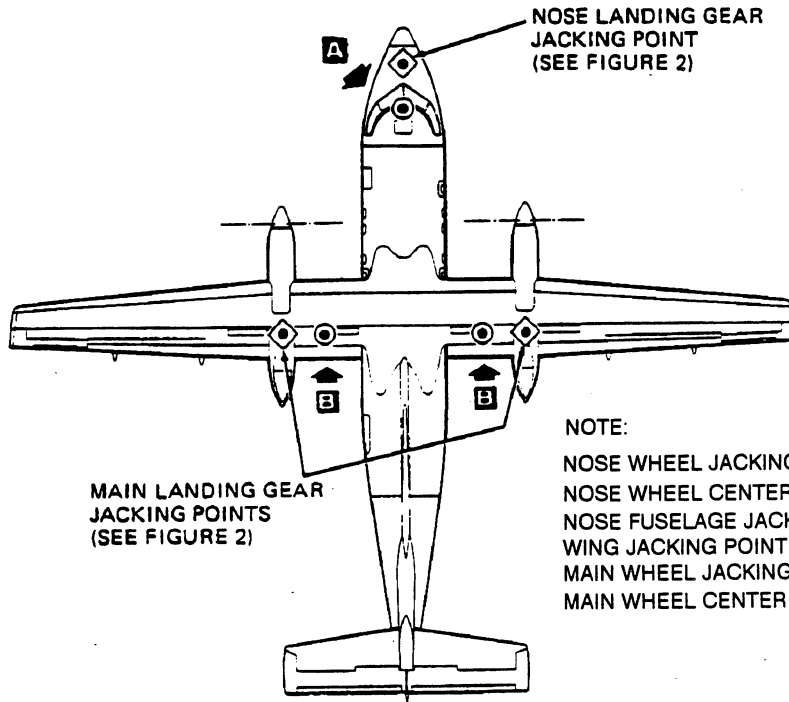

FUSELAGE NOSE JACKING POINT

**DETAIL A**

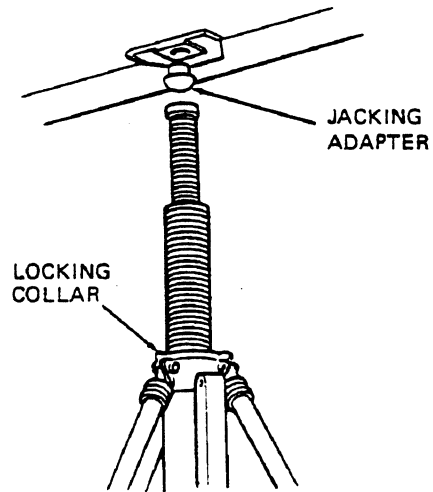

WING JACKING POINTS

**DETAIL B**

**JACKING POINT**

FIGURE 1

**3-20-01**

**Boeing Canada**  
de Havilland Division  
**DASH 8 AIRCRAFT RECOVERY**

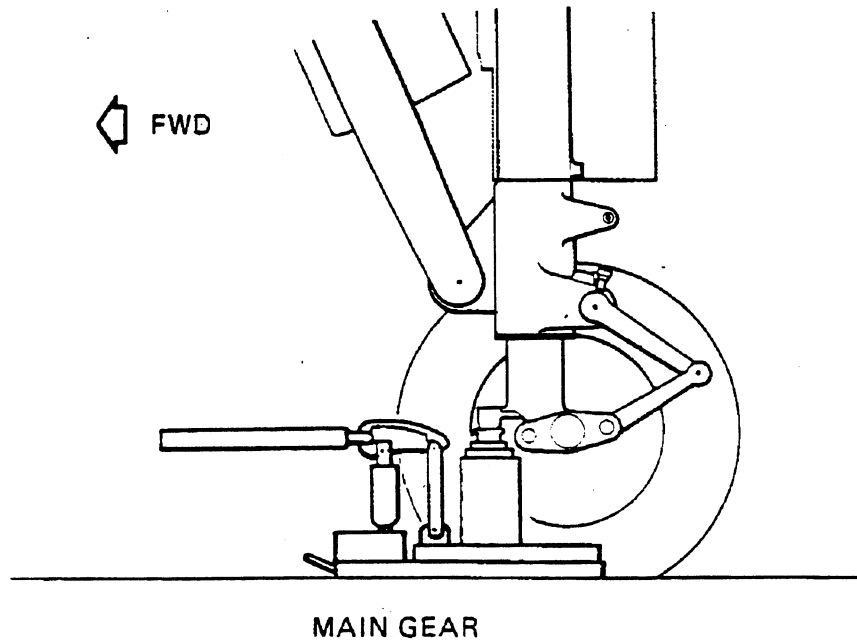
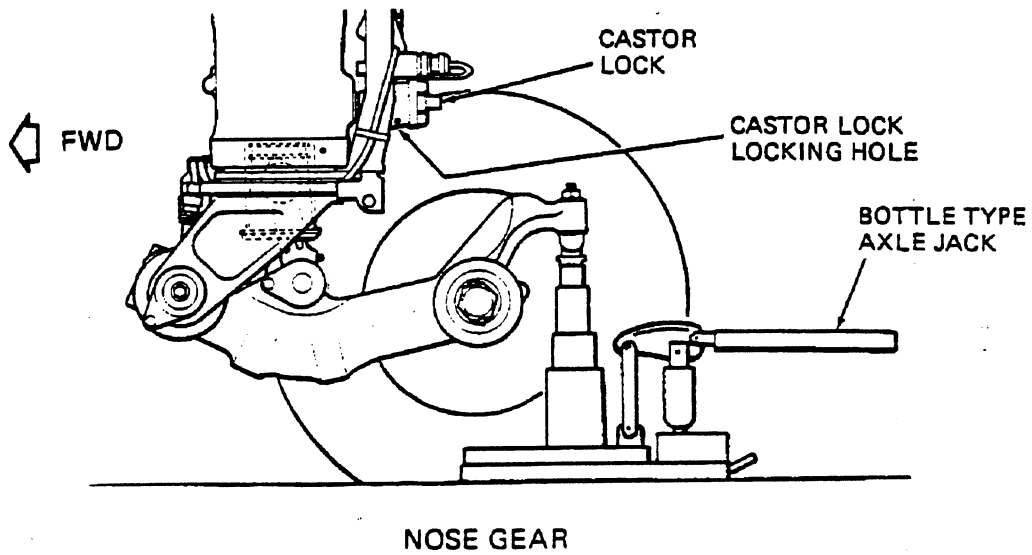

**JACKING AT LANDING GEAR AXLES**

**FIGURE 2**

**3-20-01**

PAGE 5

OCT 10/90

**Boeing Canada**  
de Havilland Division  
**DASH 8 AIRCRAFT RECOVERY**

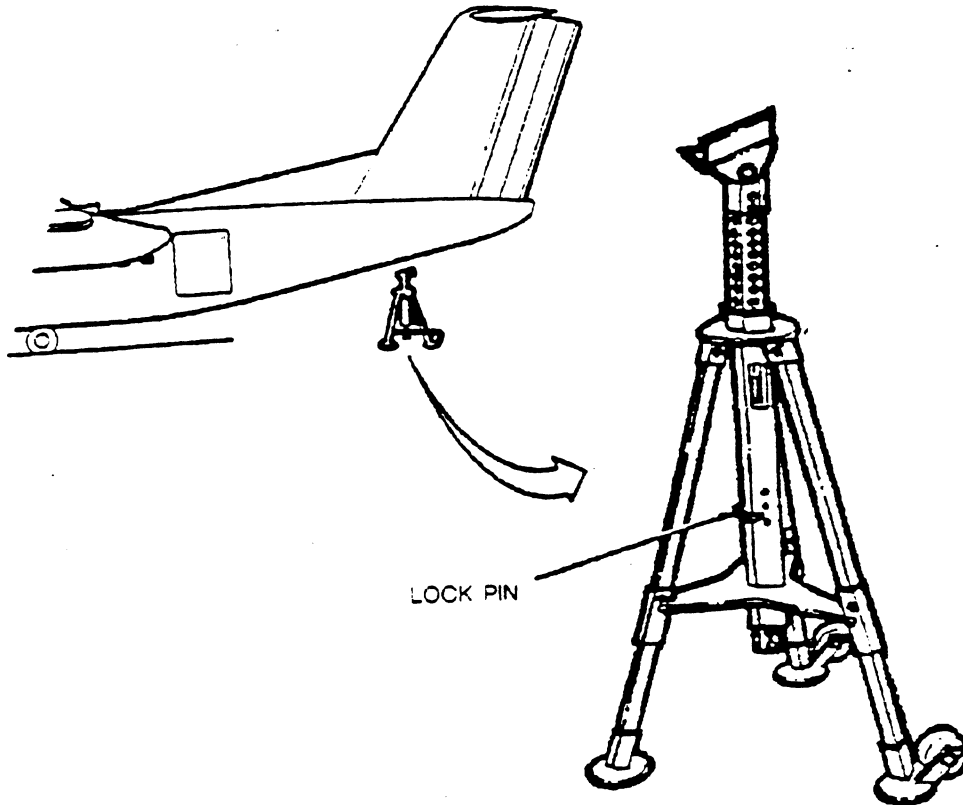

**TAIL STAND**  
**FIGURE 3**

**3-20-01**

PAGE 6

OCT 10/90



**DASH 8 AIRCRAFT RECOVERY**

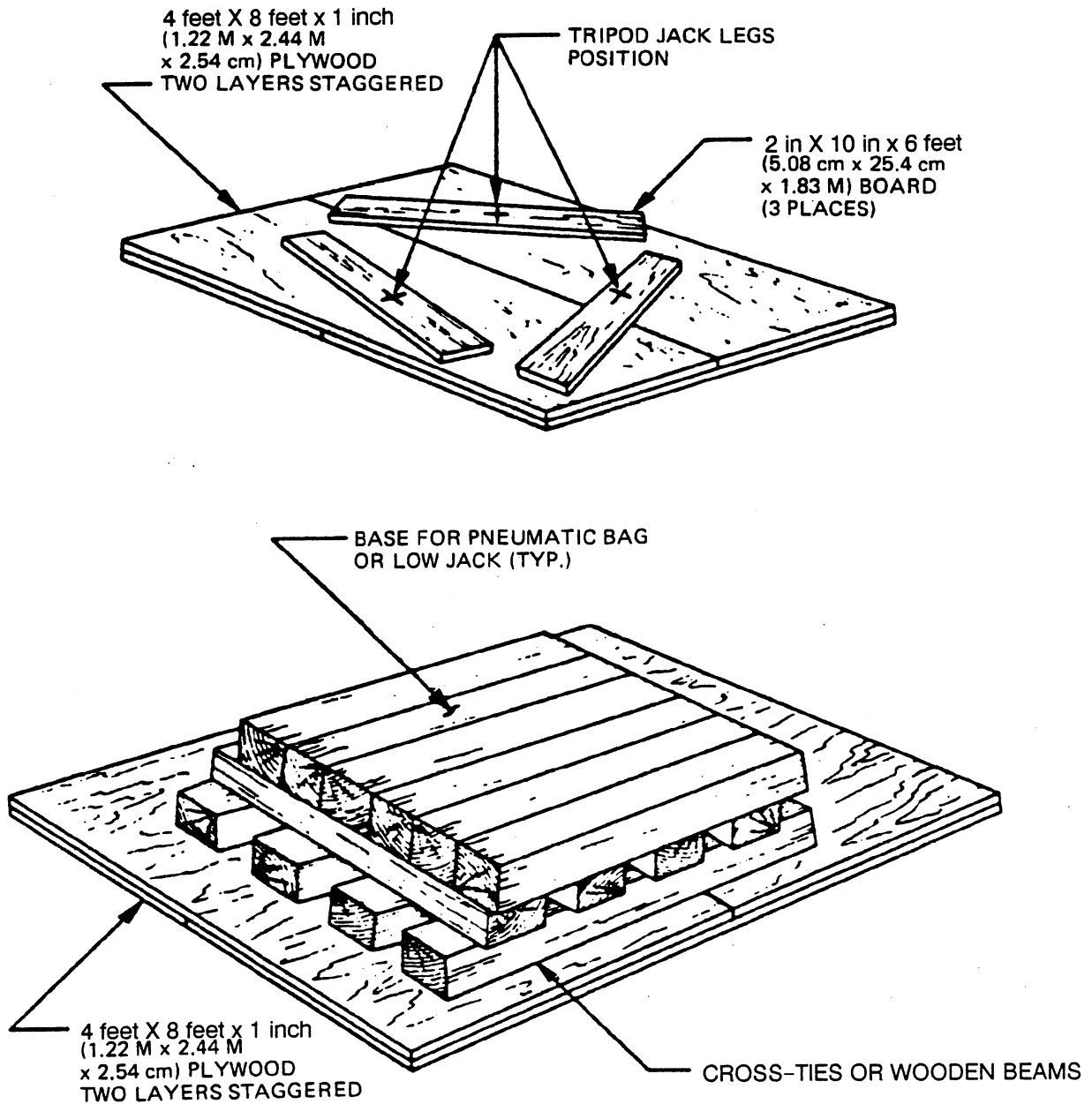

NOTE:  
SHEETS OF STEEL PLATE MAY BE USED  
IF PLYWOOD IS NOT AVAILABLE

**LIFTING BASES FOR JACKS AND  
AIRBAGS FOR SOFT GROUND**

**FIGURE 4**

**3-20-01**

**Boeing Canada**  
de Havilland Division  
**DASH 8 AIRCRAFT RECOVERY**

**THIS PAGE INTENTIONALLY LEFT BLANK**

**3-20-01**

**PAGE 8**

**OCT 10/90**

**Boeing Canada**  
de Havilland Division  
**DASH 8 AIRCRAFT RECOVERY**

**PNEUMATIC BAGS**

**1. General (Figure 1)**

- A. The lifting bags normally used for raising aircraft are the 12 ton (12193 Kg) capacity type. They are constructed of neoprene coated nylon fabric and support their rated load at 3.5 psi (0.24605 Kg/Cm<sub>2</sub>). A compressor is required to provide 40 cfm at 3.5 psi (0.24605 Kg/Cm<sub>2</sub>). The bags are basically a rectangular balloon 6 feet 6 inches x 7 feet 6 inches x 6 feet (198x229x127 cm) high when inflated. The collapsed height is about 6 inches (15.24 cm). The bags may be laced together side by side or on top of one another if more lifting height is required. Due to the instability of these bags, cribbing should be used in place of stacking when possible.
- B. Lifting bags with a capacity of 25 and 40 ton (25402 and 40643 Kg) are available at certain airports. They are of a multi element (compartmentized) design and considerably more stable than the 12 ton (12193 Kg) type. In the construction of these bags, drop-threads have been woven between the surfaces of the individual elements to restrict expansion of the element thereby producing a flat slab shape of uniform thickness. Figure 1 depicts an eleven-element bag of this design. The bags when fully inflated to 7.0 psi (0.4921 Kg/Cm<sub>2</sub>) are 9 feet 6 inches (289.6 cm) long, 6 feet 6 inches wide (203.2 cm) and 7 feet 7 inches (231.14 cm) high. The deflated size is 10 feet (304.8 cm) long, 7 feet (213.36 cm) wide and 7 inches (17.78 cm) high. The lifting area varies from 8,000 sq. in. (516.16 cm<sub>2</sub>) at 3 psi (0.2109 Kg/Cm<sub>2</sub>) to 9,300 sq. in. (60004 cm<sub>2</sub>) at 7 psi (0.4921 Kg/Cm<sub>2</sub>). The two top elements of the bags are divided into two equal compartments, the top element laterally and the second element longitudinally.

**NOTE: Do not exceed 3.5 psi (0.24605 Kg/Cm<sub>2</sub>) (in the top two lifting bag elements) when using the type of bag for lifting as damage to aircraft may result.**

- C. Pneumatic lifting bags should be positioned so that the center of lift for the combined system coincides with or is as near as possible to the center of gravity of the aircraft. Of equal importance in selecting the location for bags is to ensure that all bags will have approximately equal displacement during the lift.

**CAUTION: INSTALL AIRBAGS BELOW WINGS INBOARD OF NACELLES.**

- D. A high degree of lateral instability is inherent in any lifting bag design. Therefore the use of lifting bags should be restricted to periods when wind velocities do not exceed 20 MPH (32 per hour). In addition to this restriction, an adequate tethering technique must be employed in conjunction with the use of lifting bags.
- E. Lifting bags must be periodically pressure tested and checked for deterioration as designated by the bag manufacturer.

**3-20-02**

PAGE 1

OCT 10/90

## DASH 8 AIRCRAFT RECOVERY

### 2. Preparations for Using Pneumatic Lifting Bags

- A. When necessary prepare ground surface according to type of terrain; very soft marshy ground should be reinforced using materials available (Refer to 3-20-01 Jacking Aircraft Figure 4).

**NOTE: Care must be taken in positioning the bags to avoid covering the jacking points as it will be desirable to install jacks at the primary jack points at the earliest opportunity. Lifting bags are to provide a means for lifting an airplane and are not intended as a semi-permanent means of support.**

- B. After completing the basic preparations in paragraph A, determine the number of bags that will be required and the locations of the bags. The number and location of bags will vary with each situation however, it is best to use as many as possible to distribute the load.
- C. Clear the bag location area of any sharp objects for approximately 12 feet (4 meter) square.
- D. Place a heavy pad or mattress between the aircraft and the air bag surfaces. If padding is not available remove or tape over any sharp edges or protuberances which may damage the air bag.
- E. When using several bags under the same wing, make sure that all bags are given the same extension potential. Dihedral of the wing requires a higher base for the outer bags in proportion to the inner ones. Deflection of the wings when supporting the aircraft has a similar effect. A base can be made with railway cross ties, beams, dry earth, sand or gravel in sacks. The base should match the angle of the aircraft contact surface to minimize shift due to rotation effect. This base angle should also be considered for the overall movement of the aircraft.

### 3. Lifting with Pneumatic Bags

- A. Prior to starting lift, review the procedures and overall plan with crew members so that each understands and will anticipate problems affecting the safety of personnel or aircraft.
- B. Double check that necessary cribbing, jacks, etc., are present and tethering is complete. All lifting functions should be initially directed toward leveling the aircraft. The attitude can be monitored by using a plumb bob as outlined in Maintenance Manual PSM 1-8-2 or PSM 1-83-2 Chapter 8. A carpenter's level can also be used in place of the plumb bob by placing it on the floor of the aircraft or plumb bobs can be taped to the outside body pointing to flat plates on ground.

**3-20-02**

PAGE 2

OCT 10/90

## **DASH 8 AIRCRAFT RECOVERY**

**C. Commence Lifting as follows:**

- (1) Start compressor and inflate all bags at the same rate to distribute loads. Don't exceed allowable pressures and regulate air supply in a manner that gives a controlled lift.

**CAUTION: DO NOT ATTEMPT LIFT IF WIND EXCEEDS 20 MPH (32 KM PER HOUR)**

- (a) The sequence for inflating the bag elements shall be followed as specified by the bag manufacturer. Do not inflate the elements in contact with the aircraft surface greater than 3.5 psi (0.24605 Kg/Cm<sup>2</sup>).
- (2) When aircraft is level, any additional lifting should be done in a manner to maintain level attitude. Unlevel attitudes may cause serious shifting of aircraft. Hanging a plumb bob from the center line of the aircraft and marking a suitable target beneath will show any shift of the aircraft during the rest of the lift.
- (3) Keep tethering lines taut during lift.
- (4) Place cribbing in proper places as soon as possible. Advance cribbing as lift proceeds for safety in case of bag or hose rupture.
- (5) Continue the above method until sufficient height is reached to place conventional tripod jacks in place.
- (6) Raise aircraft in a conventional jacking manner until the planned height is reached to either lower collapsed gear, replace gear or place a flat bed trailer underneath for moving aircraft. See Maintenance Manual PSM 1-8-2 or PSM 1-83-2, Chapter 7 for normal jacking procedures.
- (7) When aircraft is secure, deflate bags by opening one or both outlets on 12 ton (12193 Kg) bags.

**NOTE: In an emergency, the use of both outlets provides a quick release of pressure.**

- (8) Remove inflation hose, replace valve cap and move tarpaulin cover, with bag still on it, to an uncongested area for packing.

**3-20-02**

PAGE 3

OCT 10/90

**Boeing Canada**  
de Havilland Division  
**DASH 8 AIRCRAFT RECOVERY**

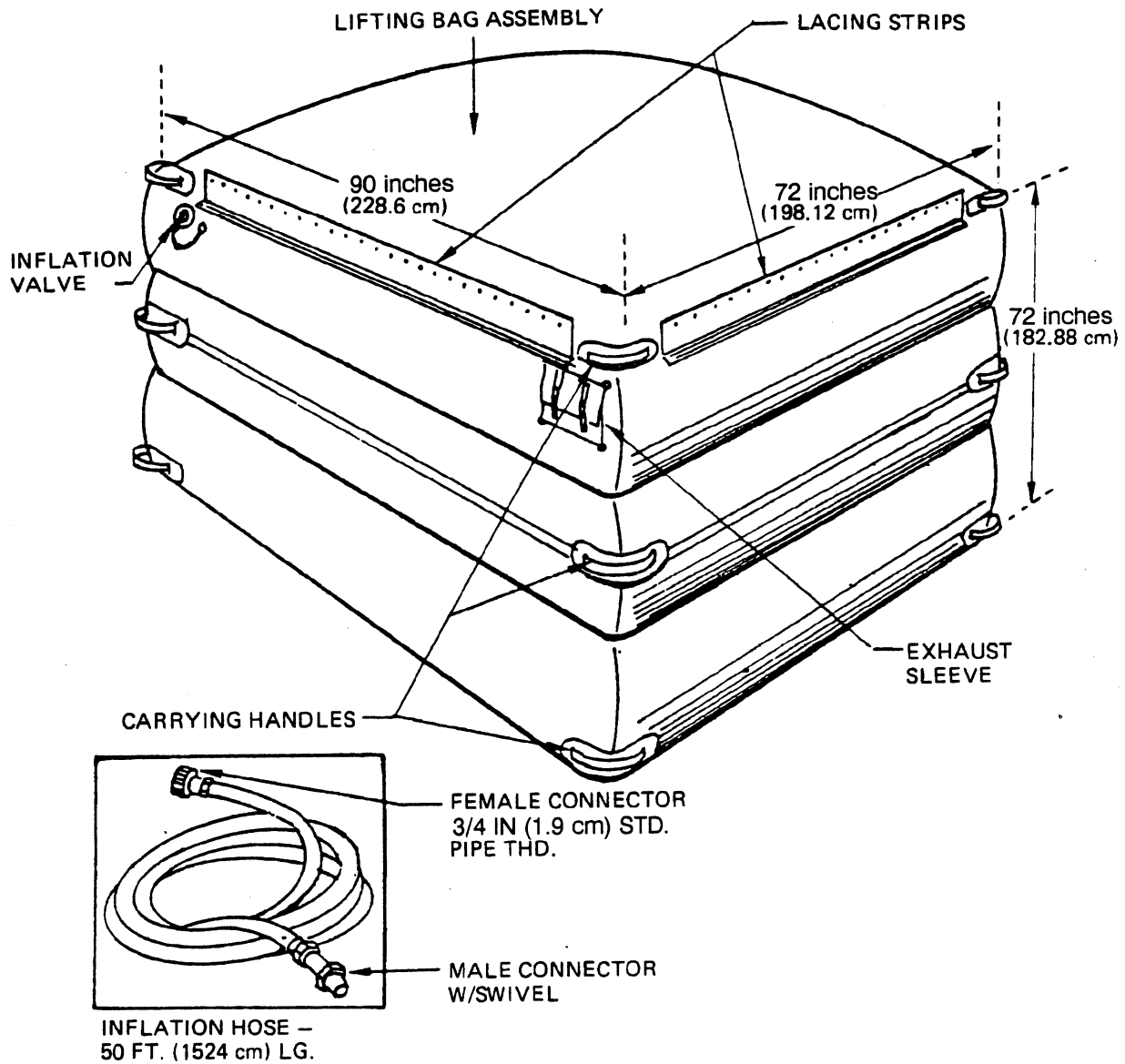

**12 TON PNEUMATIC LIFTING BAG**

**FIGURE 1**

**3-20-02**

## DASH 8 AIRCRAFT RECOVERY

### 25 TON PNEUMATIC BAG LIFTING CAPACITY IN POUNDS (KILOGRAMS)

PRESSURE P.S.I.	1 BAG	2 BAGS	3 BAGS	4 BAGS	5 BAGS	6 BAGS	7 BAGS	8 BAGS
2.13	17,130 (7,770)	34,260 (15,540)	51,390 (23,310)	68,520 (31,080)	85,650 (38,850)	102,780 (46,620)	119,910 (54,390)	137,040 (62,160)
2.84	23,500 (10,659)	47,000 (21,318)	70,500 (31,977)	94,000 (42,636)	117,500 (53,295)	141,000 (63,954)	164,500 (74,613)	188,000 (85,272)
3.56	30,100 (13,653)	60,200 (27,305)	90,300 (40,959)	120,400 (54,612)	150,500 (68,265)	180,600 (81,918)	210,700 (95,571)	240,800 (109,224)

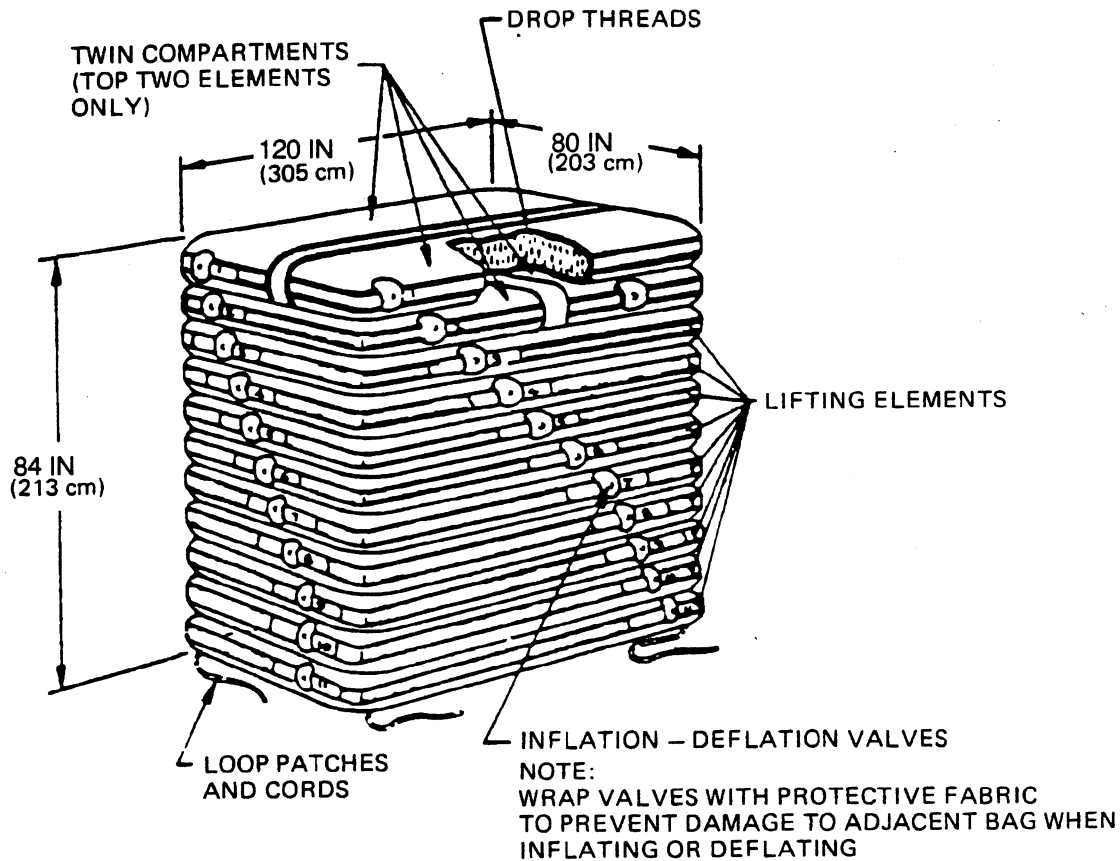

**25 TON HIGH STABILITY PNEUMATIC LIFTING BAG  
AND ITS LIFTING CAPACITY**

FIGURE 2

**3-20-02**

**Boeing Canada**  
de Havilland Division  
**DASH 8 AIRCRAFT RECOVERY**

**THIS PAGE INTENTIONALLY LEFT BLANK**

**3-20-02**

**PAGE 6**

**OCT 10/90**



## DASH 8 AIRCRAFT RECOVERY

### LIFTING AIRCRAFT WITH MOBILE CRANE

#### 1. General

- A. Where the ground surface in the vicinity of the recovery area is capable of supporting large mobile cranes, this area should first be investigated before attempting recovery.

**CAUTION: EXTREME CARE MUST BE TAKEN WHEN LIFTING AIRCRAFT WITH CRANES AND SLINGS IN WINDS OF 20 M.P.H. (32 KM/HOUR) OR OVER.**

**NOTE: The supervisor of the Recovery Team or his designated replacement must be in control of the lift operation and he alone will give the signals to the crane operators and members of recovery team.**

- B. Reduce weight of the aircraft down using methods suggested in Chapter 2-30-01.
- C. Mobile cranes required = one 5 ton (5080 Kg) and two 10 ton (10161 Kg).
- D. The aircraft can be lifted at the front fuselage by means of a crane(s) with sling or by the use of two fork lift vehicles (forks removed) and sling (See Figure 2).

#### 2. Preparation for Using Mobile Crane

- A. Position mobile crane(s) for lifting aircraft.

**WARNING: DO NOT OPERATE MOBILE CRANES IN EXCESS OF RATED LOAD. THE LOAD RATINGS CHANGE AS THE ANGLE OF BOOM VARIES FROM THE HORIZONTAL. FACTORS WHICH AFFECT THE LOADING CAPACITY OF THE POWER BOOM ARE HYDRAULIC PRESSURE, BOOM ANGLE AND LUBRICATION.**

- B. Jibs, when installed, are intended to increase lifting height. They are not to be used to increase operating radius.
- C. To obtain the net lifting capacity of the boom at a certain boom angle, deduct from the load rating the weight of all suspended load handling devices such as hooks, hook-blocks, slings, boom extension, jib, etc.

**CAUTION: EMPLOY ONLY EXPERIENCED CRANE OPERATORS AND HOOK TENDERS. CRANE OPERATORS MUST BE ABLE TO JUDGE FACTORS AFFECTING THE MACHINE SUCH AS WIND EFFECT ON THE LIFTED LOAD, GROUND CONDITIONS, CRANE OUT OF LEVEL, OPERATING SPEEDS AND OTHER FACTORS WHICH MIGHT AFFECT THE SAFE OPERATION OF HIS MACHINE. REDUCE THE LOAD RATINGS TO COMPENSATE ACCORDINGLY.**

- D. Visually check all slings for wear and tear. Do not use if sling shows any sign of damage. When installing the sling to lift the aircraft, protect the aircraft skin from abrasion with padding or other equivalent material.

# 3-20-03

## DASH 8 AIRCRAFT RECOVERY

- E. Check that tethering lines are taut.

**NOTE:** Review the procedures with all crew members so they can anticipate problems of safety to personnel and aircraft.

### 3. Forward Fuselage (Figure 1)

- A. When all preparations are complete, the nose should be raised very slowly to the height required. Sling location at station X182.0.
- B. The tethering lines must be adjusted continuously during the lift.
- C. At the desired height the weight of the forward fuselage will be transferred to the nose gear, flatbed trailer (dolly, etc.) or tripod jack. Because the jack pads are located beneath the sling, it will be necessary to support the aircraft with cribbing so the sling can be removed if jack is used.

**NOTE:** The aircraft may be moved with the mobile crane supporting the nose if conditions warrant.

- D. After transfer of load safety to another means of support, remove the crane(s) sling.

### 4. Three Point Lift

- A. Aircraft may be lifted by means of cranes and slings at front fuselage and outboard of nacelle on wings.

**WARNING:** LIFTING BY THIS METHOD REQUIRES CLOSE COORDINATION OF EACH CRANE SO AS TO KEEP AIRCRAFT LEVEL DURING LIFT.

**CAUTION:** SLING LOCATIONS:

FRONT FUSELAGE X 182.0
RIGHT WING YW 189.0
LEFT WING YW 189.0
REAR FUSELAGE X 653.349

- B. Manufacture wing support beam to fit under wing, to same contour as underside of wing, thick padding to be used between beam and wing.
- C. Commence lifting by slowly taking slack out of slings. When all slings are taut, commence lifting at a very slow rate. Tethering lines should be let out during the lift but kept tight enough to stabilize the aircraft.
- D. Stop periodically to check all slings and attitude of aircraft. Level if necessary.
- E. When aircraft reaches desired height, crib as necessary and lower aircraft on to landing gear, jacks or flatbed trailer(s).

**3-20-03**

Boeing Canada  
de Havilland Division  
**DASH 8 AIRCRAFT RECOVERY**

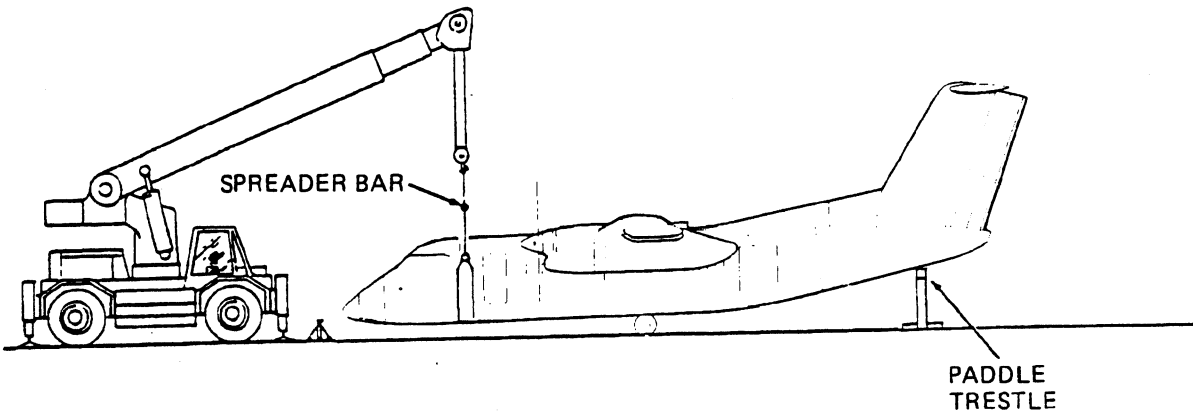
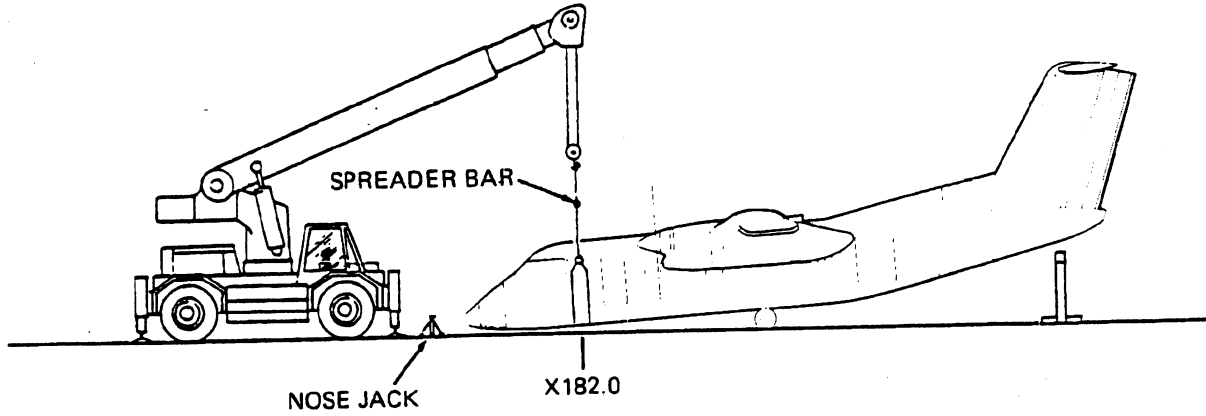

**LIFTING NOSE WITH MOBILE CRANE**

**FIGURE 1**

**3-20-03**

# DASH 8 AIRCRAFT RECOVERY

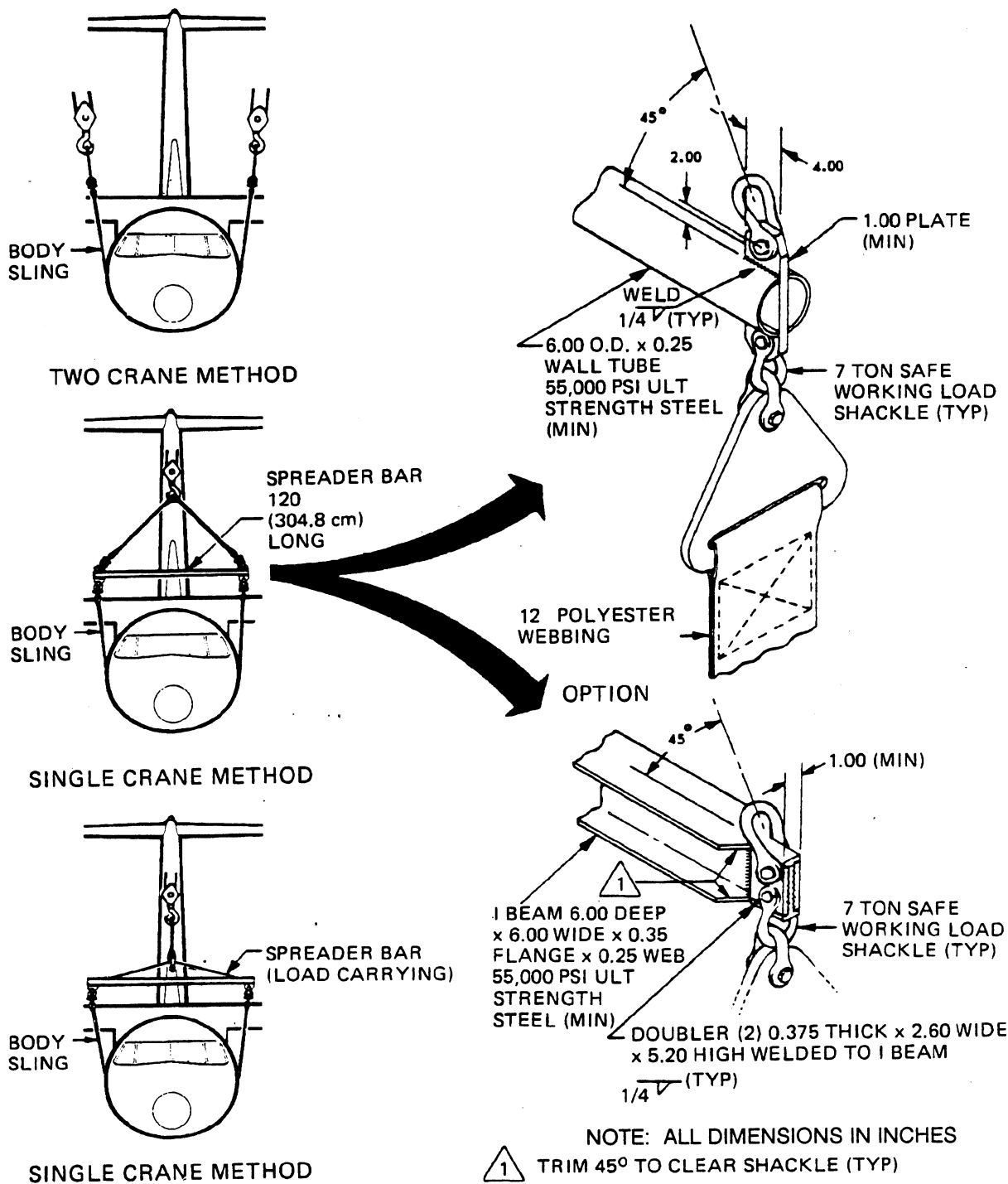

LIFTING NOSE-WITH MOBILE CRANES

FIGURE 2 (SHEET 1)

## 3-20-03

Boeing Canada  
de Havilland Division  
**DASH 8 AIRCRAFT RECOVERY**

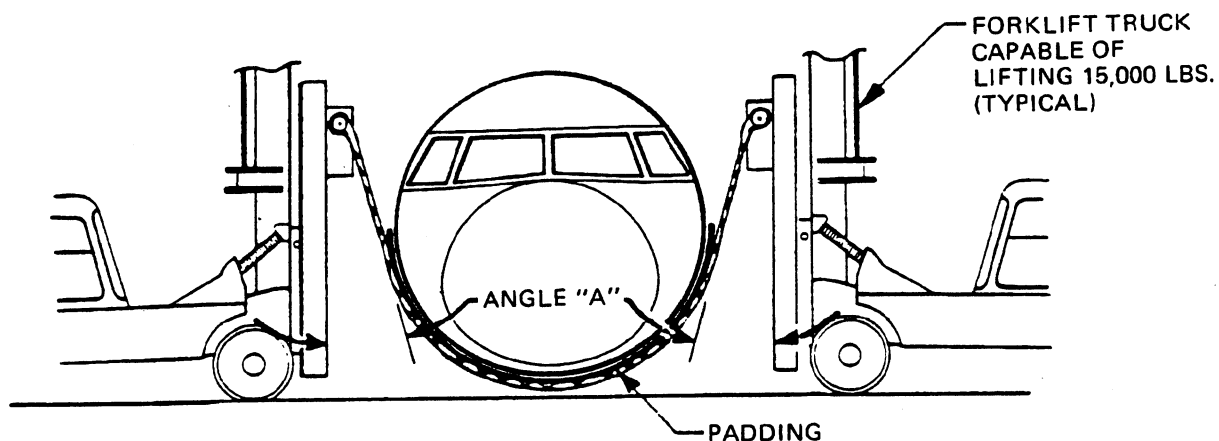

**NOTE:**

ATTACH SLING TO THE LIFTING FITTINGS OF THE FORK LIFT VEHICLES. ANGLE "A" SHALL BE MAINTAINED AT LESS THAN 20 DEGREES TO PREVENT TIPPING OF THE FORK LIFT VEHICLES. IF CABLES ARE USED IN LIEU OF A SLING, THE FUSELAGE SHALL BE PROTECTED BY PADDING OR THIN PLYWOOD TO PREVENT DAMAGE. MAINTAIN CLEARANCE AT FORWARD JACK PAD FITTING TO ALLOW INSTALLATION OF FORWARD BODY SUPPORT JACK.

**LIFTING NOSE-BY USE OF TWO FORK LIFT  
VEHICLES AND SLING**

**FIGURE 2 (SHEET 2)**

**3-20-03**

PAGE 5

OCT 10/90

## DASH 8 AIRCRAFT RECOVERY

### 5. Lifting Sling Requirements (Figure 3)

- A. Forward Fuselage – The sling used should be 12 to 18 inches (30.48 to 45.72 cm) wide and rated at 15,000 pounds (6804 Kg) maximum safe working load.

**CAUTION: IF A SINGLE CRANE IS USED, A SPREADER BAR MUST BE USED TO PREVENT ANY CRUSHING OF FUSELAGE.**

- B. A sling similar to that above can be fabricated in short time if the materials are available.

**NOTE: A safety factor of 5 to 1 (ultimate strength to maximum working load) should be included in the design calculations.**

- C. Place thick padding between the sling and skin to distribute load and reduce local abrasion.

- D. Hook sling to crane and take up slack.

**3-20-03**

# DASH 8 AIRCRAFT RECOVERY

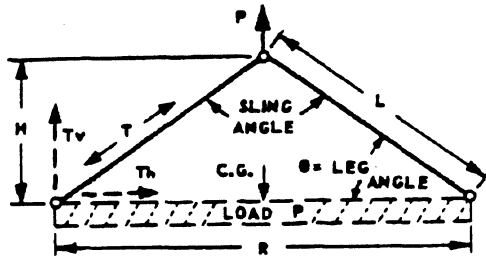

- T = TENSION OR PULL IN ONE LEG OF SLING - TO FIND "T" MULTIPLY THE TOTAL LOAD "P" BY MULTIPLIER "A" .....  $T = P \times A$
- W = LOAD CAPACITY OF SLING - TO FIND "W" MULTIPLY THE SAFE WORKING STRENGTH OF THE SLING MATERIAL "S" BY MULTIPLIER "B" .....  $W = S \times B$
- H = HEIGHT OF SLING - TO FIND "H" MULTIPLY THE REACH "R" BY MULTIPLIER "C" .....  $H = R \times C$
- L = LENGTH OF SLING LEG - TO FIND "L" MULTIPLY THE REACH "R" BY MULTIPLIER "D" .....  $L = R \times D$
- R = REACH OF SLING - TO FIND "R" MULTIPLY THE LENGTH OF THE SLING LEG "L" BY MULTIPLIER "E" .....  $R = L \times E$
- S = SAFE WORKING STRENGTH OF THE SLING MATERIAL - TO FIND "S" DIVIDE THE BREAKING STRENGTH OF THE SLING MATERIAL BY A SUITABLE FACTOR OF SAFETY.
- $T_v = 1/2 P = T \sin Q$
- $T_h = T \cos Q$

2 LEGGED SLINGS AT VARIOUS ANGLES					
MULTIPLIERS					
A	0.500	0.577	0.610	0.653	0.707
B	2.000	1.732	1.638	1.532	1.414
C	---	0.866	0.714	0.596	0.500
D	---	1.000	0.872	0.778	0.707
E	---	1.000	1.147	1.286	1.414
MULTIPLIERS					
A	0.778	0.872	1.000	1.183	1.462
B	1.286	1.147	1.000	0.845	0.684
C	0.420	0.350	0.289	0.233	0.182
D	0.653	0.610	0.577	0.552	0.532
E	1.532	1.638	1.732	1.813	1.879

MULTIPLIERS FOR SLING CAPACITY CALCULATIONS

FIGURE 3

3-20-03

# DASH 8 AIRCRAFT RECOVERY

**Note:**

**Basic Sling Configurations**

Shown below are illustrations of some basic sling arrangements with vertical legs. Legs  $5^\circ$  or less from the vertical may be considered vertical.

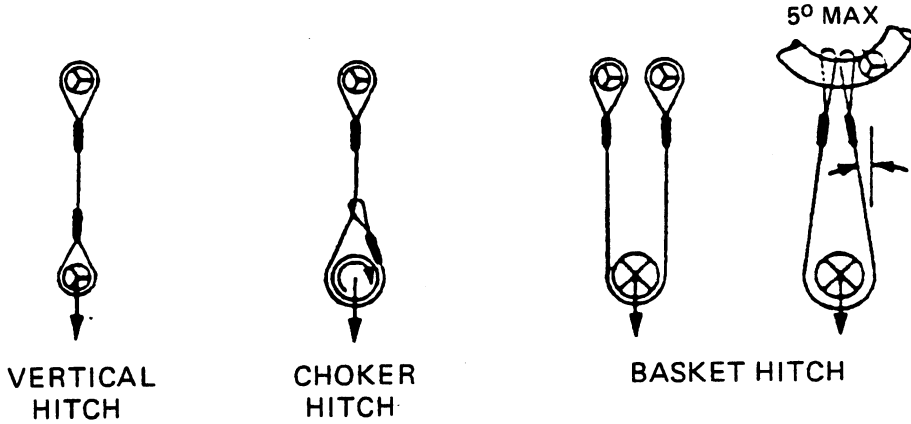

**Eye and Eye Sling**

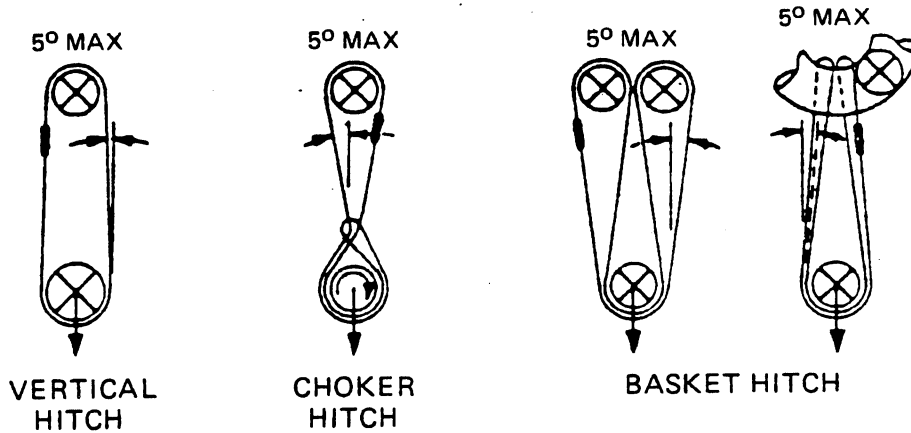

**Endless Sling**

**BASE SLING CONFIGURATIONS**

**FIGURE 4**

**3-20-03**



**Boeing Canada**  
de Havilland Division  
**DASH 8 AIRCRAFT RECOVERY**

**LIFTING**

**1. Nose Gear Collapsed (Figure 1)**

Configuration: Nose Down, Wings Level, Nose Area Damage

- A. The fastest method of lifting is the use of a mobile crane and sling if available and ground conditions allow, sling location X 182.0.

**CAUTION: CHOCK BOTH M.L.G. FRONT AND BACK TO PREVENT AIRCRAFT FROM ROLLING DURING LIFTING OPERATION.**

**NOTE: Ensure tail stand or airbag is positioned approximately 8 inches (20 cm) ahead of tail cone.**

- B. Install airbags under fuselage as far forward as is possible and inflate.

**WARNING: THE AIRCRAFT SHOULD BE SET ON CRIBBING OR JACKS WHEN SUFFICIENT HEIGHT IS REACHED AND AIRBAGS REMOVED BECAUSE OF THEIR INHERENT INSTABILITY.**

- C. Cushion downward motion of tail by lowering of tail stand or controlled deflation of rear airbag.
- D. Simultaneously use jacks, airbags or slings to assist in raising and supporting forward fuselage.
- E. If damage permits, lower and install lock pin in nose gear or support nose section on flatbed or similar mobile unit.
- F. Move aircraft, towing from main landing gear and guiding from nose unit.

**2. Main Gear Collapsed (Figure 2)**

Configuration: Tail Down, Extensive to moderate damage to mid fuselage, wings level or one wing down with wing tip damage, propeller damage, possible damage to main gear and nacelle.

**NOTE: Chock nose wheels fore and aft.**

- A. Support rear fuselage by adjustable tail stand or airbag.
- B. Install jacks at wing jack points. Install airbags inboard of nacelles on both wings.

**NOTE: The use of jacks and airbags requires careful consideration to tethering, cribbing should be advanced as a safety measure.**

- C. Level aircraft laterally by co-ordinated wing jack and airbag handling.
- D. Crane(s) and slings can be effectively used for a lifting alternative or as an assist to jacks and airbags. Sling location for wings YW 189.0.

**3-20-04**

## DASH 8 AIRCRAFT RECOVERY

**NOTE:** Supervisor of recovery team or designated replacement should be in control of the lift operation and he alone will give the signals to all members of recovery team.

- E. Raise and support tail section by means of tail stand, airbags, or jack.
- F. If possible, extend main landing gear and install lock pins or support on flatbed as required. Chock wheels where possible.
- G. Remove chocks and move aircraft, towing from nose and main landing gear.

### 3. Main Gear Collapsed One Side (Figure 3)

Other main gear and nose gear extended, ground lock pins installed and wheels chocked.

Configuration: Tail Down, Damage to mid fuselage, One wing tip down to wing tip, outer wing panel and propeller.

**NOTE:** Defueling the low wing tank(s) only will result in a considerable weight reduction on that side and will move C.G. toward opposite wing thus reducing the lifting force required.

- A. Support aircraft using airbag and jacks at front and rear fuselage.
- B. Install and inflate airbags inboard of nacelle on high wing.
- C. Install jack at jacking point and airbags outboard of nacelle on low wing.
- D. Level aircraft laterally by co-ordinated wing jack and airbag operation, crane and sling can be used as an alternative or assist on low wing.
- E. Raise and support tail section.
- F. If possible, extend and install ground lock pin on collapsed main gear or support on cradled flatbed as required.
- G. Remove wheel chocks, move aircraft, towing from nose gear and main gears.

### 4. Nose Gear and One Main Gear Collapsed (Figure 4)

Other main gear extended and ground lock pin installed.

Configuration: Aircraft resting on fuselage with one wing down. Damage to lower fuselage, wing tip, outer wing panel, propeller and possibly nacelle and landing gear.

- A. Install wheel chocks on extended main gear if possible.

**CAUTION:** TETHERING OF AIRCRAFT IS REQUIRED WHILE JACKS, AIRBAGS AND/OR CRANES WITH SLINGS ARE BEING USED IN THE RECOVERY OPERATION.

- B. Support rear fuselage using airbags, jacks and/or crane and sling.
- C. Temporarily sand bag both sides of the nose section.

**3-20-04**

## **DASH 8 AIRCRAFT RECOVERY**

- D. Install jacks at wing jack positions.
- E. Install airbags under both wings inboard of nacelle. Cranes and slings can be used as an alternative or an assist.
- F. Excavate below nose section to install nose jack, airbag or sling.
- G. Raise aircraft and level by co-ordinating jack, airbag or sling.
- H. If possible, extend and lock main and nose gear. Alternatively use flatbed, or other mobile unit to support main and nose gear as required.
- I. Remove chocks and move aircraft, towing from main and nose gear.

### **5. Main and Nose Landing Gears Collapsed (Figure 5)**

Configuration: Aircraft resting on fuselage, probably with one wing down. Damage to full length of lower fuselage, one wing tip and outer wing panel with possible damage to opposite wing. Damage to one or both propellers, possible damage to nacelles and landing gears.

**CAUTION: ENSURE THE FOLLOWING PRECAUTIONS ARE FOLLOWED:**

**DEFUEL AIRCRAFT, ALL TANKS - REFER TO CHAPTER 2-30-4.  
DO NOT LIFT OR JACK AIRCRAFT IN WIND CONDITIONS ABOVE 20  
M.P.H. (32 KM/HR).  
PAY LOAD AND COMPONENT REMOVED FROM AIRCRAFT TO REDUCE  
WEIGHT REFER TO CHAPTER 2-30-00.  
STABILIZE AIRCRAFT BY MEANS OF TETHER LINES REFER TO  
CHAPTER 3-10-00**

- A. Support rear fuselage using airbags, jacks and/or crane and sling.
- B. Temporarily sandbag both sides of nose section.
- C. Install jacks at wing jack positions.
- D. Install airbags at both inboard side of nacelles. Cranes and slings can be used as an alternative or an assist.
- E. Excavate below nose section to install nose jack, airbag or sling.
- F. Raise aircraft and level by co-ordinating jack, airbag, crane and sling handling.
- G. If possible extend and lock main and nose gear. Alternatively use flatbed or other mobile unit to support aircraft as required.
- H. Move aircraft to repair area.

**3-20-04**

**Boeing Canada**  
de Havilland Division  
**DASH 8 AIRCRAFT RECOVERY**

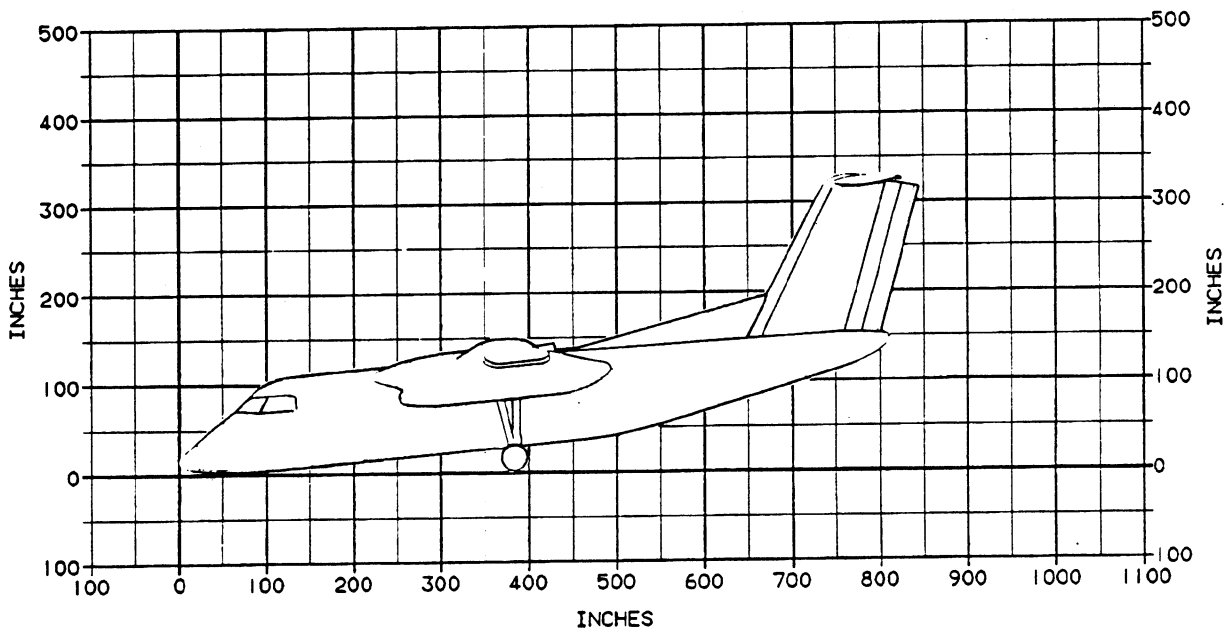
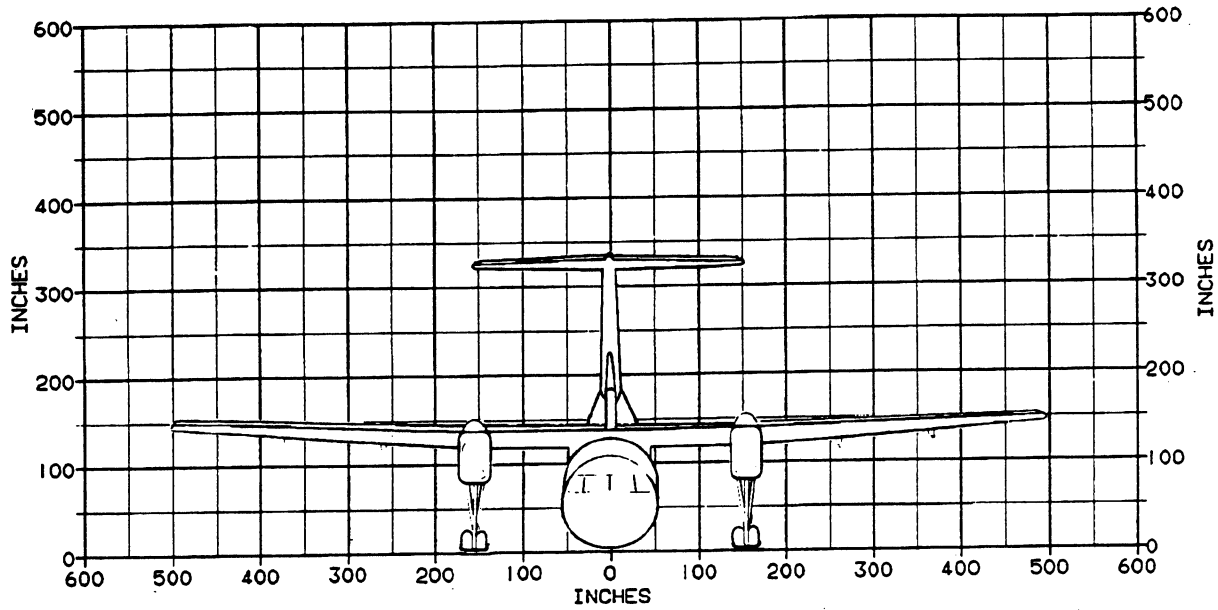

**COLLAPSED NOSE GEAR - BOTH MAIN GEAR EXTENDED**

**FIGURE 1**

**3-20-04**

**Boeing Canada**  
de Havilland Division  
**DASH 8 AIRCRAFT RECOVERY**

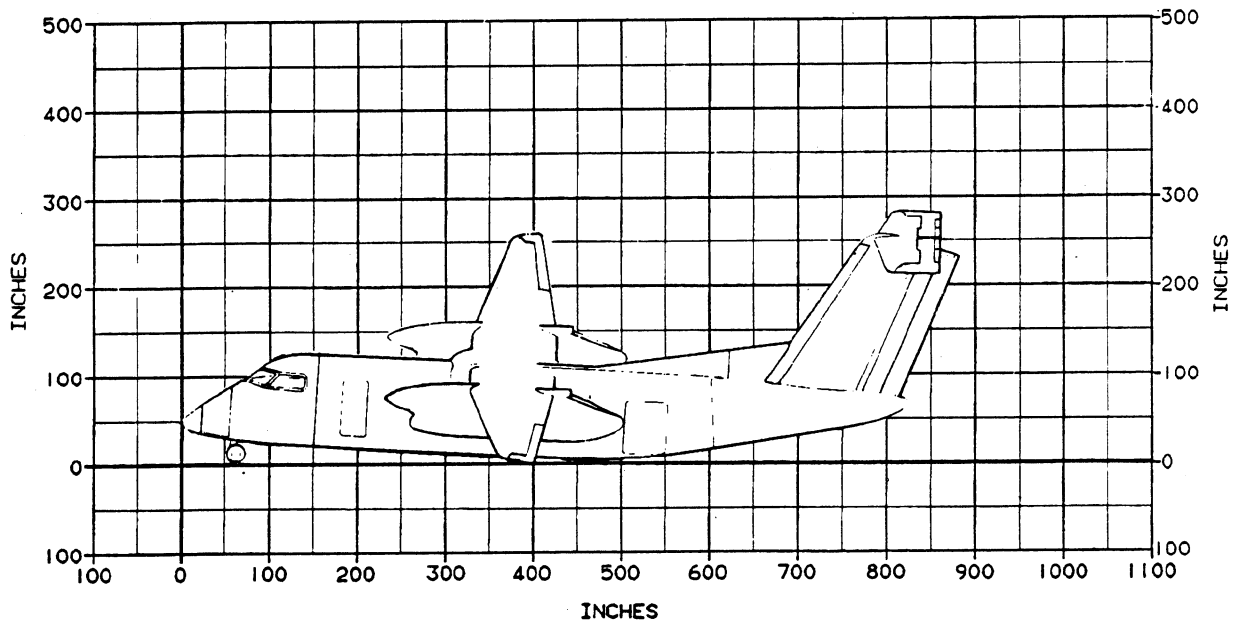
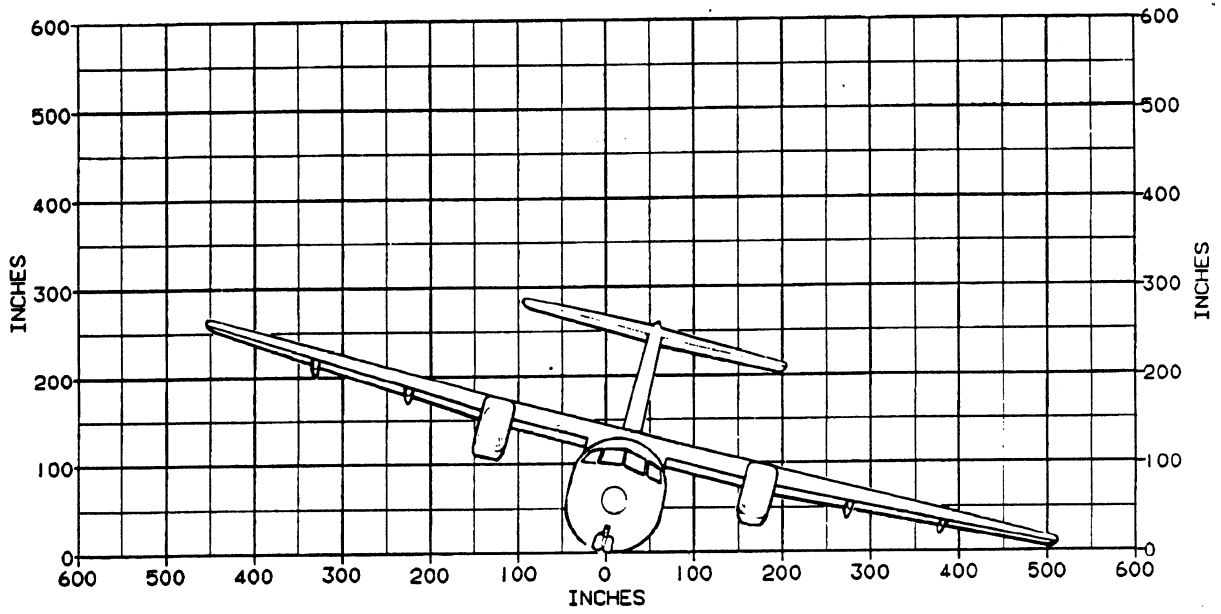

**COLLAPSED MAIN GEAR - BOTH SIDES**

**FIGURE 2**

**3-20-04**

**Boeing Canada**  
de Havilland Division  
**DASH 8 AIRCRAFT RECOVERY**

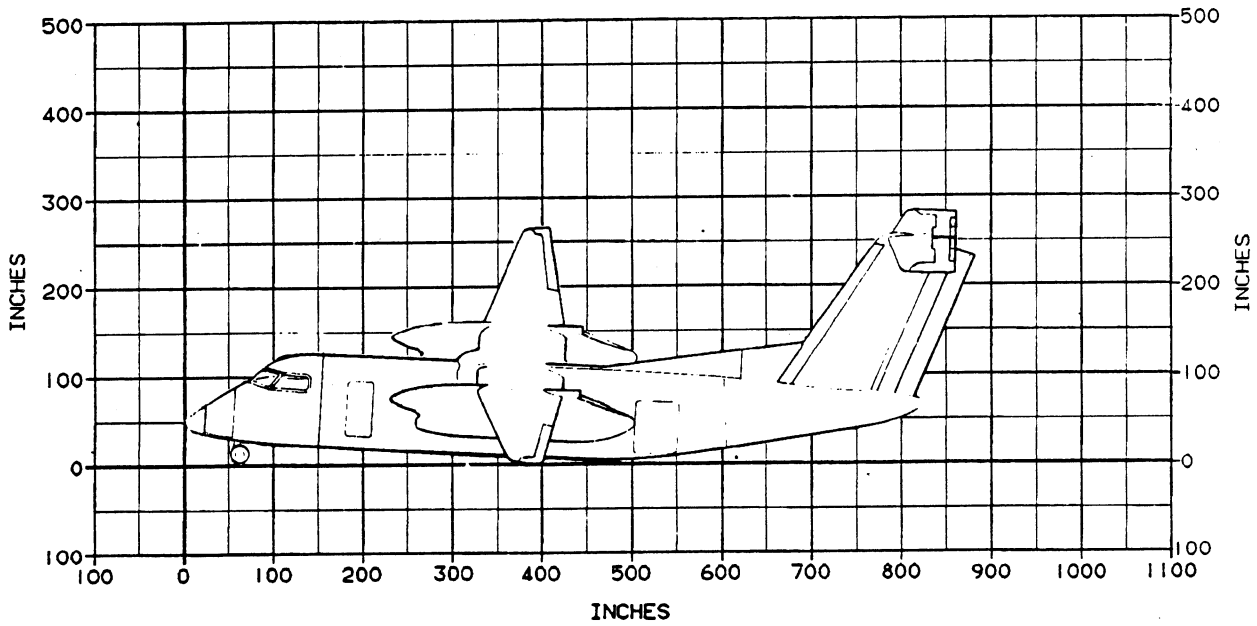
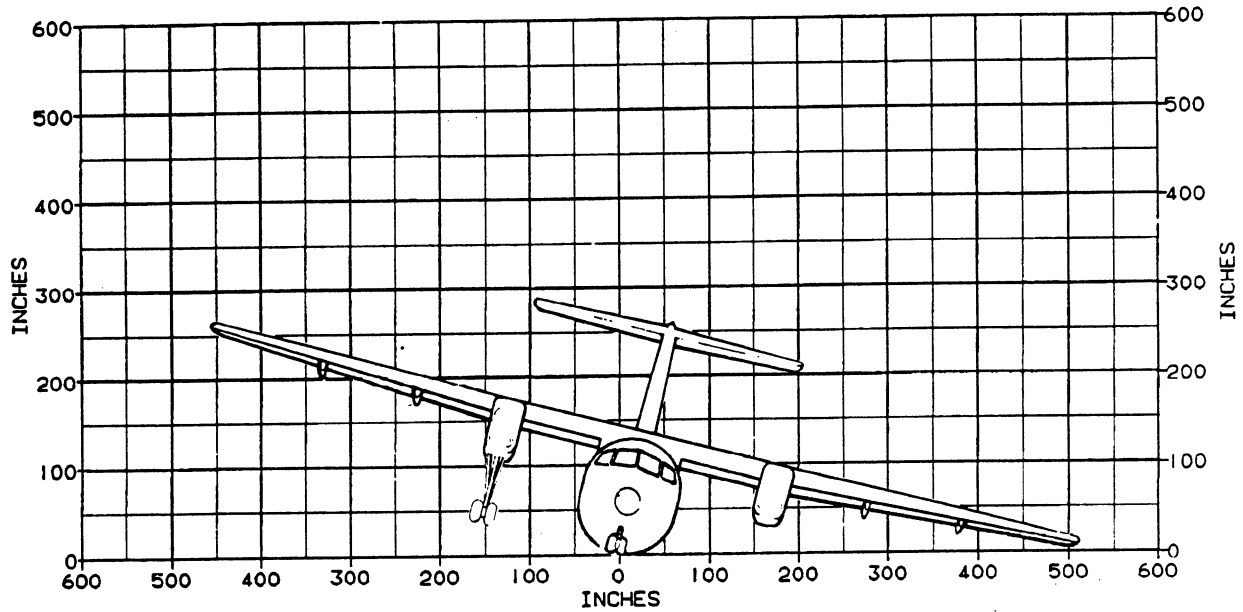

**COLLAPSED MAIN GEAR - ONE SIDE**

**FIGURE 3**

**3-20-04**

**Boeing Canada**  
de Havilland Division  
**DASH 8 AIRCRAFT RECOVERY**

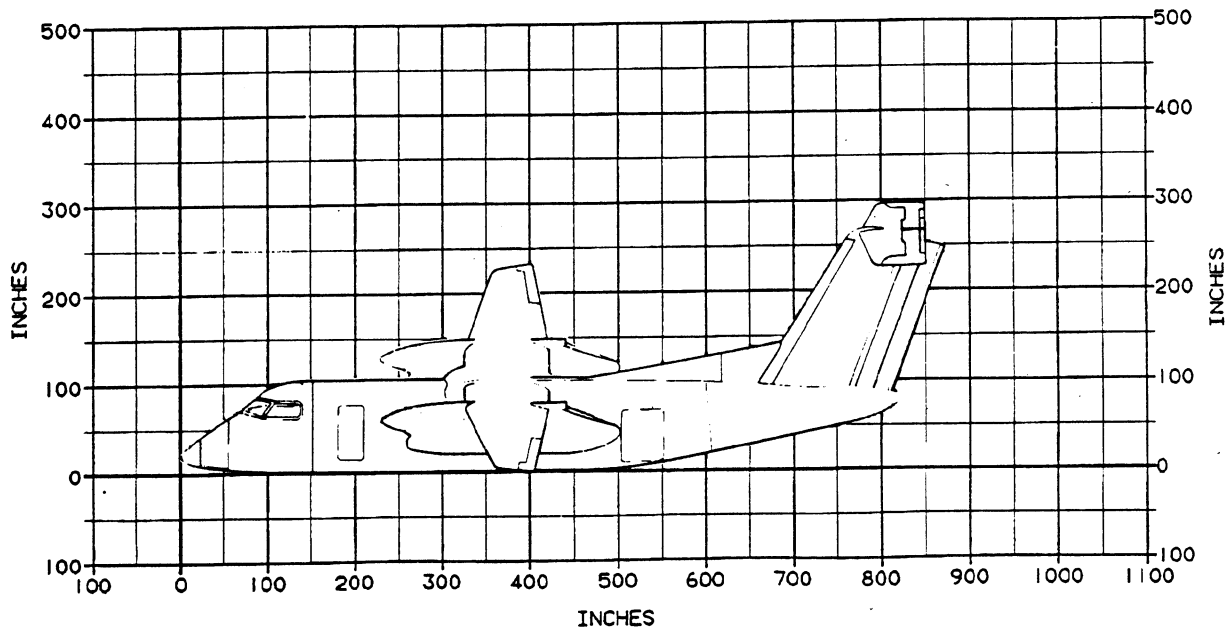
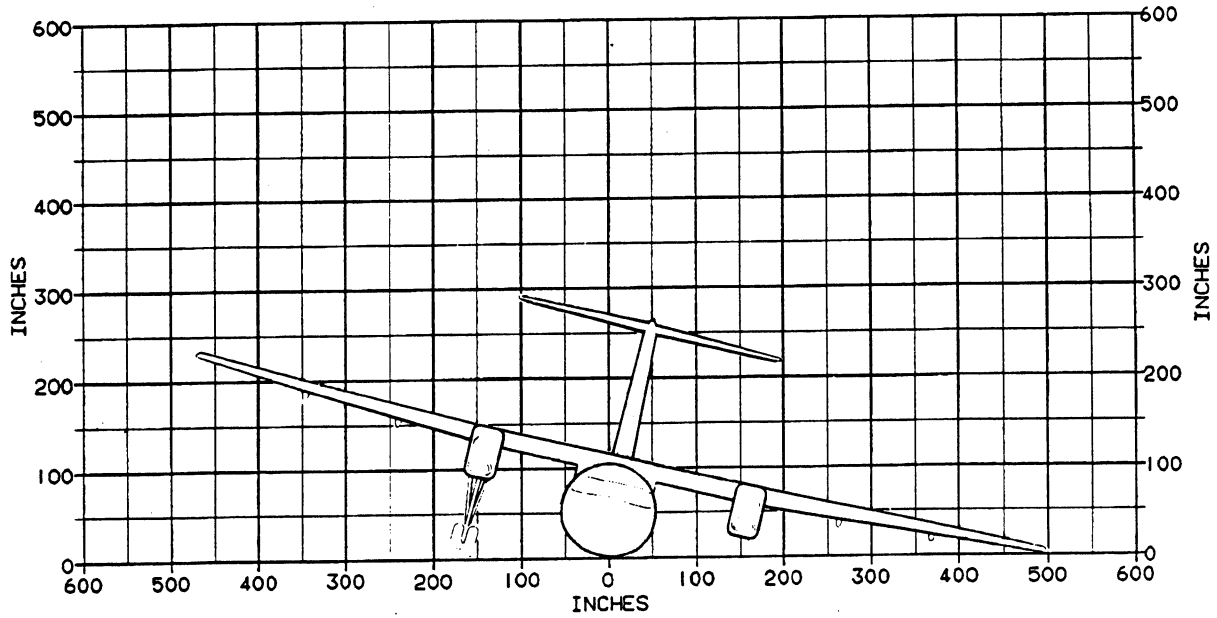

**COLLAPSED NOSE GEAR AND MAIN GEAR  
ONE SIDE**

**FIGURE 4**

**3-20-04**

**Boeing Canada**  
de Havilland Division  
**DASH 8 AIRCRAFT RECOVERY**

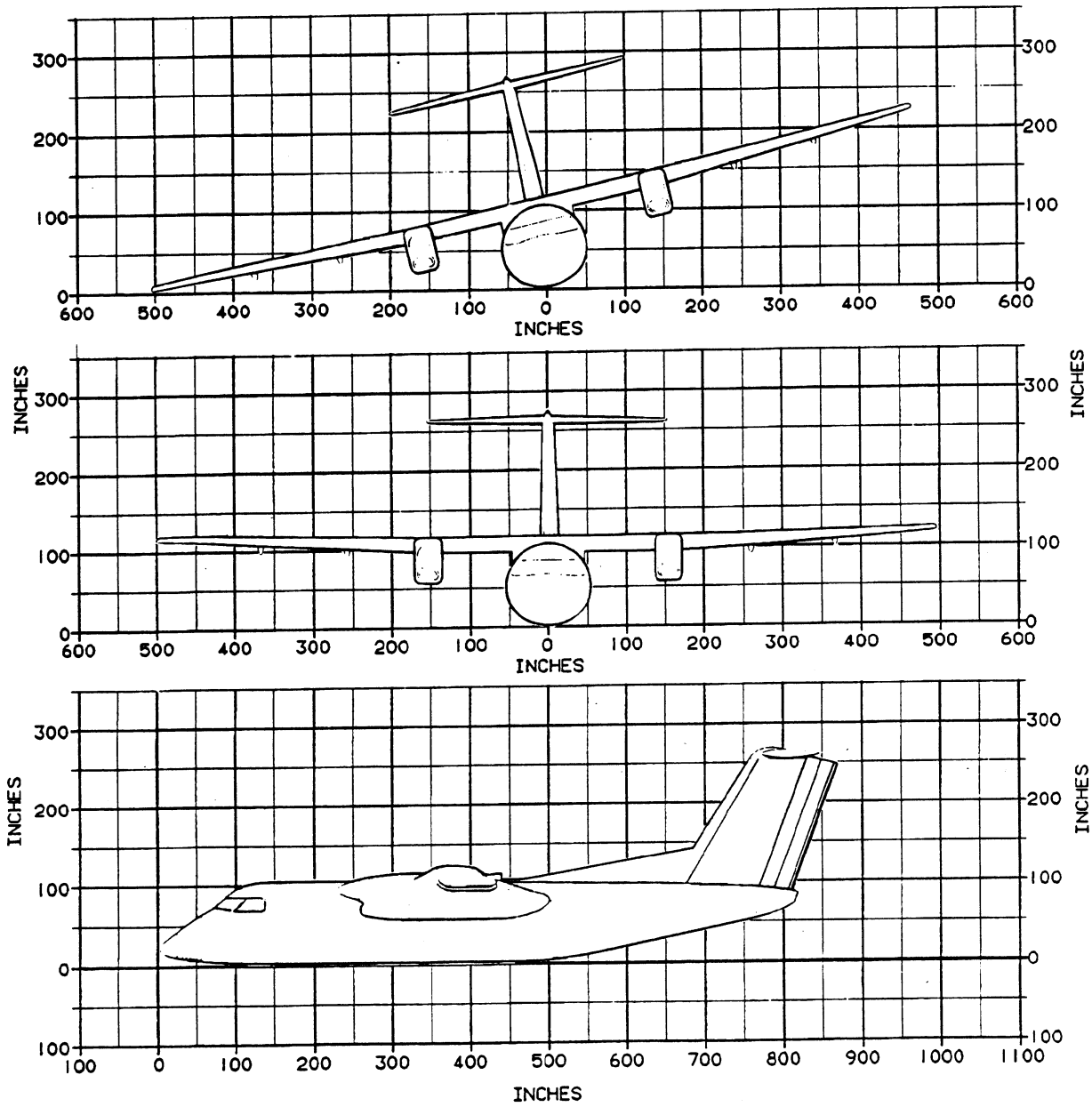

**COLLAPSED LANDING GEAR - ALL**

**FIGURE 5**

**3-20-04**



## DASH 8 AIRCRAFT RECOVERY

### LIFTING MATERIALS AND ATTACHMENTS

#### 1. Straps

- A. Fabric straps of woven material such as nylon, dacron, etc., are most often used for lifting and hoisting the aircraft structure to keep the skin surfaces from being marred or scratched. Nylon and dacron webbings are more resistant to abrasion, have less moisture absorption, quick drying and are resistant to rot and mold. However, prolonged exposure to high temperature and low humidity will reduce its moisture content and consequently make it brittle and subject to failure. It has been found that nylon straps exposed to 125 degrees F. (52 degrees C.) air for 120 hours failed at lower than normal load. If these conditions are anticipated, polypropylene straps should be used instead of nylon.
- B. In general, webbing straps must be matched closely to the service conditions and have adequate protective devices and increased factors of safety. Some webbing straps have wire woven in them for strength. Manufacturer's catalogs should be consulted for information on product characteristics and load ratings. Factor of safety for fabric materials used in overhead lifts usually is 20. However, consult the manufacturer's catalog and follow its recommendations to match the service conditions.
- C. Based on safety test data, it has been determined that nylon web slings have severely reduced capacity when used to lift loads having sharp edges, ie., when the radius is less than 3/16 inch (.48 cm.). Figure 1 shows the rated capacity of nylon rope slings.

EDGE RADIUS OF LOAD INCH (CENTIMETERS)	REDUCTION IN RATED CAPACITY %
3/16 (.48)	NONE
5/32 (.397)	5
1/8 (.318)	15
3/32 (.238)	25
1/16 (.159)	40
1/32 (.079)	55
0 ---	85

**3-20-05**

**DASH 8 AIRCRAFT RECOVERY**

**RATED CAPACITY IN POUNDS (KGs) SAFETY FACTOR = 9**

NYLON ROPE SLINGS		RATED CAPACITY IN POUNDS (KGs) SAFETY FACTOR = 9						
		EYE AND EYE SLING			ENDLESS SLING			
NOM. ROPE DIA INCHES (CM)	NOM. WEIGHT LB/FT (KG/M)	MINIMUM BREAKING STRENGTH LBS. (KG)	VERTICAL HITCH	CHOKER HITCH	BASKET HITCH 0° ANGLE OF ROPE TO VERTICAL	VERTICAL HITCH	CHOKER HITCH	BASKET HITCH 0° ANGLE OF ROPE TO VERTICAL
1/2 (1.27)	0.65 (.0437)	6,080 (2,747.4)	700 (317.5)	350 (158.7)	1,400 (634.9)	1,200 (544.2)	600 (272)	2,400 (1,088.4)
3/4 (1.91)	.145 (.098)	13,490 (6,117.9)	1,500 (680.3)	750 (340.1)	3,000 (1,360.5)	2,700 (1,224.5)	1,400 (634.9)	5,400 (2,449)
1 (2.54)	.26 (.175)	23,750 (10,779)	2,600 (1,179.1)	1,300 (598.6)	5,300 (2,403.6)	4,800 (2,176.9)	2,400 (1,088.4)	9,500 (4,308.4)
1 1/2 (3.81)	.55 (.370)	50,350 (22,834.5)	5,600 (2,539.9)	2,800 (1,269.8)	11,000 (4,988.7)	10,000 (4,535.2)	5,000 (2,267.6)	20,000 (9,070.4)
1 3/4 (4.45)	.83 (.518)	74,100 (33,605.4)	8,200 (3,718.8)	4,100 (1,859.4)	16,500 (7,483)	15,000 (6,802.7)	7,400 (3,356)	29,500 (13,378.7)
2 (5.08)	.95 (.639)	87,400 (39,605.4)	9,700 (4,399.1)	4,900 (2,222.2)	19,500 (8,843.5)	17,500 (7,936.5)	8,700 (3,945.6)	35,000 (15,873)
2 1/4 (5.72)	1.29 (.867)	118,750 (53,854.9)	13,000 (5,895.7)	6,600 (2,993.2)	26,500 (12,018)	24,000 (10,884.4)	12,000 (5,442.2)	47,500 (21,542)
2 1/2 (6.35)	1.49 (1.002)	133,000 (60,317.5)	15,000 (6,802.9)	7,400 (33.56)	29,500 (13,378.7)	26,500 (12,018.1)	13,500 (6,122.5)	53,000 (24,036.3)

**RATED CAPACITY OF NYLON ROPE SLINGS**

**FIGURE 1**

**3-20-05**

## **DASH 8 AIRCRAFT RECOVERY**

### **2. Manila Rope (Abaca) (Figure 2)**

- A. Manila rope can be used for tie downs. It may be employed with block and tackle for hoisting operations. Its use as load droppers or for direct attachment to loads is to be avoided because of susceptibility to cutting action.
- B. When using Manila rope, be aware that it absorbs water. Freezing temperature will freeze the water in the rope considerably reducing its breaking strength. Also, Manila rope shrinks, which must be taken into account when applying positive loading on the restraining cables.

### **3. Chains (Figure 2)**

- A. Hoisting chains are manufactured from a good grade wrought iron because of its ductility and toughness. These characteristics provide advance warning before breaking by bending or stretching.
- B. Some desirable characteristics which make chain popular for use in lifting equipment are:
  - (1) the links are smooth and will not injure a workman's hands.
  - (2) it is flexible and easy to handle.
  - (3) it will not develop kinks.
  - (4) there is no tendency to twist or spin the load.
  - (5) strength is not affected when subjected to a moderate amount of rough handling, heat, corrosion or abrasion.
- C. On account of its flexibility and weight, its use in close proximity to the aircraft should be deferred in preference to wire rope unless precautionary measures are used like plywood padding to protect the aircraft skins.

### **4. Wire Rope (Figure 2)**

- A. Wire ropes are made up of a number of strands laid helically around and independent wire or non-metallic center. Hemp fiber core is widely used when loads are not too great. The core supports the strands in position and acts as a cushion to prevent nicking of the wires.
- B. The important characteristics of wire rope made of improved plow steel are strength, high degree of flexibility, wear resistance and resistance to distortion.
- C. Wire rope size is commonly designated by two figures; the first indicates the number of strands and the second, the number of wires per strand.

Example: A 6 X 7 is a six strand rope having seven wires per strand.

The diameter of a wire rope is that diameter of the circle which will just enclose it.

- D. Factors of safety for operating rope are from 5 to 12. Where there is hazard to life of property, higher values are used.

**3-20-05**

**Boeing Canada**  
de Havilland Division

**DASH 8 AIRCRAFT RECOVERY**

- E. Evidence of rope deterioration from corrosion should be cause for replacement. Breaks in any strand that occur in the valleys between strands indicate some abnormal condition, possible fatigue and breakage of other wires not readily visible. One or more valley breaks should be cause for replacement.
- F. Wire breaks generally occur in those portions of a wire rope which pass over sheaves, wind over drums or have received mechanical abuse.

**3-20-05**

PAGE 4

OCT 10/90

**Boeing Canada**  
de Havilland Division  
**DASH 8 AIRCRAFT RECOVERY**

TRADE SIZE DIA. IN. (CM)	CHAIN						WIRE ROPE IMPROVED PLOW STEEL - HEMP CENTER						MANILA ROPE				
	WROUGHT IRON DREDGE QUALITY			ALLOY STEEL - HEAT TREATED			6 X 19 CONSTRUCTION			6 X 37 CONSTRUCTION			8 X 19 CONSTRUCTION			THREE-STRAND	
	UNIT WEIGHT LBS./FT. (KG/M)	BREAKING STRENGTH LBS. (KG)	UNIT WEIGHT LBS./FT. (KG/M)	BREAKING STRENGTH LBS. (KG)	UNIT WEIGHT LBS./FT. (KG/M)	BREAKING STRENGTH LBS. (KG)	UNIT WEIGHT LBS./FT. (KG/M)	BREAKING STRENGTH LBS. (KG)	UNIT WEIGHT LBS./FT. (KG/M)	BREAKING STRENGTH LBS. (KG)	UNIT WEIGHT LBS./FT. (KG/M)	BREAKING STRENGTH LBS. (KG)	UNIT WEIGHT LBS./FT. (KG/M)	BREAKING STRENGTH LBS. (KG)	UNIT WEIGHT LBS./FT. (KG/M)	BREAKING STRENGTH LBS. (KG)	
1/4 (.635)	.78 (1.16)	4,500 (2,401)	.73 (1.08)	10,500 (4,762)	.10 (.15)	5,800 (2,630)	.10 (.15)	5,600 (2,540)	.09 (.13)	4,490 (2,240)	.020 (.03)	600 (272)					
3/8 (.953)	1.66 (2.47)	9,300 (4,218)	1.59 (2.37)	22,500 (10,204)	.23 (.34)	12,600 (5,714)	.22 (.33)	12,200 (5,532)	.20 (.30)	10,900 (4,943)	.041 (.061)	1,350 (612)					
1/2 (1.27)	2.95 (4.39)	16,500 (7,483)	2.77 (4.12)	40,000 (18,141)	.40 (.60)	21,600 (9,796)	.39 (.58)	21,200 (9,615)	.36 (.54)	19,000 (8,617)	.075 (.111)	2,650 (1,202)					
5/8 (1.59)	4.30 (6.40)	25,000 (11,338)	4.33 (6.44)	59,500 (26,984)	.63 (.94)	33,200 (15,057)	.61 (.91)	32,200 (14,603)	.57 (.85)	28,800 (13,061)	.133 (.198)	4,400 (1,996)					
3/4 (1.91)	6.15 (9.15)	35,400 (16,054)	6.36 (9.46)	77,500 (35,147)	.90 (1.34)	47,400 (21,497)	.87 (1.29)	45,600 (20,680)	.82 (1.22)	41,000 (18,594)	.167 (.248)	5,400 (2,449)					
7/8 (2.22)	8.20 (12.20)	48,000 (21,769)	8.68 (12.90)	104,000 (47,1660)	1.23 (1.83)	64,400 (29,206)	1.19 (1.77)	61,000 (27,664)	1.11 (1.65)	55,200 (25,034)	.225 (.33)	7,700 (3,493)					
1 (2.54)	10.45 (15.55)	62,000 (28,118)	11.23 (16.71)	135,000 (61,225)	1.60 (2.38)	84,000 (38,095)	1.55 (2.31)	79,000 (35,828)	1.45 (2.16)	71,600 (32,472)	.270 (.402)	9,000 (4,082)					
1 1/8 (2.86)	13.10 (19.49)	78,000 (35,374)	-----	-----	2.03 (3.02)	106,000 (48,073)	1.96 (2.92)	99,800 (45,261)	1.84 (2.74)	90,400 (40,998)	.360 (.536)	12,000 (5,442)					
1 1/4 (3.175)	16.00 (23.81)	96,000 (43,537)	-----	-----	2.50 (3.72)	130,000 (58,957)	2.42 (3.60)	123,000 (55,782)	2.27 (3.38)	111,400 (50,522)	.418 (.62)	13,500 (6,124)					
1 3/8 (3.49)	19.30 (28.72)	115,000 (52,154)	-----	-----	3.03 (4.51)	157,000 (71,202)	2.93 (4.36)	148,600 (67,392)	2.74 (4.08)	134,000 (60,771)	-----	-----					
1 1/2 (3.81)	23.00 (34.22)	136,000 (61,678)	-----	-----	3.60 (5.36)	185,000 (83,900)	3.49 (5.19)	176,400 (80,000)	3.26 (4.85)	159,000 (72,109)	.600 (.89)	18,500 (8,390)					

**AVERAGE BREAKING STRENGTH OF SELECTED SLING MATERIALS**  
**FIGURE 2**

- NOTES: 1. BREAKING STRENGTH MUST BE DIVIDED BY A SUITABLE "FACTOR OR SAFETY" AND WILL BE GOVERNED BY THE DEGREE OF SAFETY REQUIRED FOR THE WORK AT HAND.  
2. SEE MANUFACTURER'S CATALOGS FOR SPECIFIC LOAD RATING.

**3-20-05**

**Boeing Canada**  
de Havilland Division  
**DASH 8 AIRCRAFT RECOVERY**

**THIS PAGE INTENTIONALLY LEFT BLANK**

**3-20-05**

PAGE 6

OCT 10/90

**Boeing Canada**  
de Havilland Division

**DASH 8 AIRCRAFT RECOVERY**

**LIST OF EFFECTIVE PAGES: CHAPTER 4: MOVING AIRCRAFT**

<b>Reference</b>	<b>Page</b>	<b>Date</b>	<b>Reference</b>	<b>Page</b>	<b>Date</b>
Contents	1	Oct 10/90			
	2	Blank			
4-00-00	1	Oct 10/90			
	2	Blank			
4-10-00	1	Oct 10/90			
	2	Oct 10/90			
4-20-00	1	Oct 10/90			
	2	Oct 10/90			
	3	Oct 10/90			
	4	Oct 10/90			
	5	Oct 10/90			
	6	Oct 10/90			
	7	Oct 10/90			
	8	Oct 10/90			
	9	Oct 10/90			
	10	Oct 10/90			
	11	Oct 10/90			
	12	Oct 10/90			
4-30-00	1	Oct 10/90			
	2	Oct 10/90			
	3	Oct 10/90			
	4	Blank			

The asterisk (\*) indicates pages revised, added or deleted by current revision.

**4 - EFFECTIVE PAGES**

**Boeing Canada**  
de Havilland Division  
**DASH 8 AIRCRAFT RECOVERY**

**THIS PAGE INTENTIONALLY LEFT BLANK**

**4 – EFFECTIVE PAGES**

PAGE 2

OCT 10/90



## **DASH 8 AIRCRAFT RECOVERY**

### **CHAPTER 4 - MOVING AIRCRAFT**

#### **TABLE OF CONTENTS**

<b>Subject</b>	<b>Chapter Section Subject</b>	<b>Page</b>
<b>MOVING AIRCRAFT</b>	<b>4-00-00</b>	
General		1
<b>MOVING DAMAGED AIRCRAFT</b>	<b>4-10-00</b>	
General		1
Methods and Equipment		
Dummy Landing Gear		
Low Bed Trailers		
<b>TOWING AND WINCHING</b>	<b>4-20-00</b>	
General		1
Towing from Nose Landing Gear		
Towing or Winching from Main Landing Gear		
Limit Loads and Towing Angles		2
<b>RETURNING UNDAMAGED AIRCRAFT TO A HARD SURFACE</b>	<b>4-30-00</b>	
General		1
Inspection of Aircraft		
Aircraft Recovery Planning		
Prepare Aircraft for Moving		
Return Aircraft to Hard Surface		

## **4-CONTENTS**

**Boeing Canada**  
de Havilland Division  
**DASH 8 AIRCRAFT RECOVERY**

**THIS PAGE INTENTIONALLY LEFT BLANK**

**4-CONTENTS**

PAGE 2

OCT 10/90

**Boeing Canada**  
de Havilland Division

**DASH 8 AIRCRAFT RECOVERY**

**MOVING AIRCRAFT**

**General**

Before moving the aircraft from the site of an incident to a permanent repair facility, several activities may have to be completed, ie. defueling, removal of payload, removal of propellers and engines and preparation of site, also when required approval from authorities to move the aircraft.

In the recovery of an aircraft, consideration must be given to moving the aircraft using its own landing gear, this requires early determination of the landing gear if it can be extended, repaired or its complete replacement is necessary.

If the landing gear is not useable, other means of support must be used. Alternate support such as cradling the collapsed landing gear on a low bed trailer or transportation dolly, lifting with mobile crane, or resting the aircraft on a commercial transporter may be considered.

**4-00-00**

PAGE 1

OCT 10/90

**Boeing Canada**  
de Havilland Division  
**DASH 8 AIRCRAFT RECOVERY**

**THIS PAGE INTENTIONALLY LEFT BLANK**

**4-00-00**

PAGE 2

OCT 10/90

**DASH 8 AIRCRAFT RECOVERY****MOVING DAMAGED AIRCRAFT****1. General**

Methods and equipment described to transport the aircraft assuming parts of the Landing Gear are unservicable.

**CAUTION: IF ALL THREE LANDING GEAR HAVE SUFFERED DAMAGE IT IS MOST LIKELY THAT THE AIRFRAME HAS ALSO SUSTAINED EXTENSIVE DAMAGE AND ECONOMIC RECOVERY MAY NOT BE FEASIBLE.**

**2. Methods and Equipment (Figure 1)**

- A. With the nose gear and or either of the main landing gear unuseable for moving the aircraft, alternate forms of wheeled transport must be substituted.
- B. When large construction type cranes and flatbeds are available it is possible to lift the complete aircraft and load it on a specially constructed padded cradle on a flatbed carrier.
- C. If above means of transport is not practical smaller flatbed carriers can be used in combination to lift and move the aircraft. Ensure that suitable padding is used, mattresses, sandbags, partially inflated airbags or old pneumatic tires can be used successfully to protect the aircraft from additional damage.

**3. Dummy Landing Gear**

- A. Complete fabricated replacement landing gear can be manufactured and kept in readiness as part of the AIRCRAFT RECOVERY PLAN. This is normally manufactured by an agency specializing in aircraft recovery.
- B. Replacement sections of landing gear can be fabricated at the incident site to expedite raising or moving of aircraft. Any such improvisation must be capable of meeting the stresses which will be encountered when aircraft is moved and not result in failure and further damage to aircraft or injury to recovery crew personnel.

**4. Low Bed Trailers**

- A. Low bed trailers may be used for transporting aircraft with collapsed gears. However, the aircraft must be lashed to the trailer to prevent any movement during the move. Figure 1 shows the aircraft in a forward towing configuration.
- B. To prevent damage to the undersurfaces of the aircraft while in contact with the trailer, suitable padding must be employed. The use of rubber tires or sand bags has proven to be excellent means of protection.

**4-10-00**

PAGE 1

OCT 10/90

**Boeing Canada**  
de Havilland Division  
**DASH 8 AIRCRAFT RECOVERY**

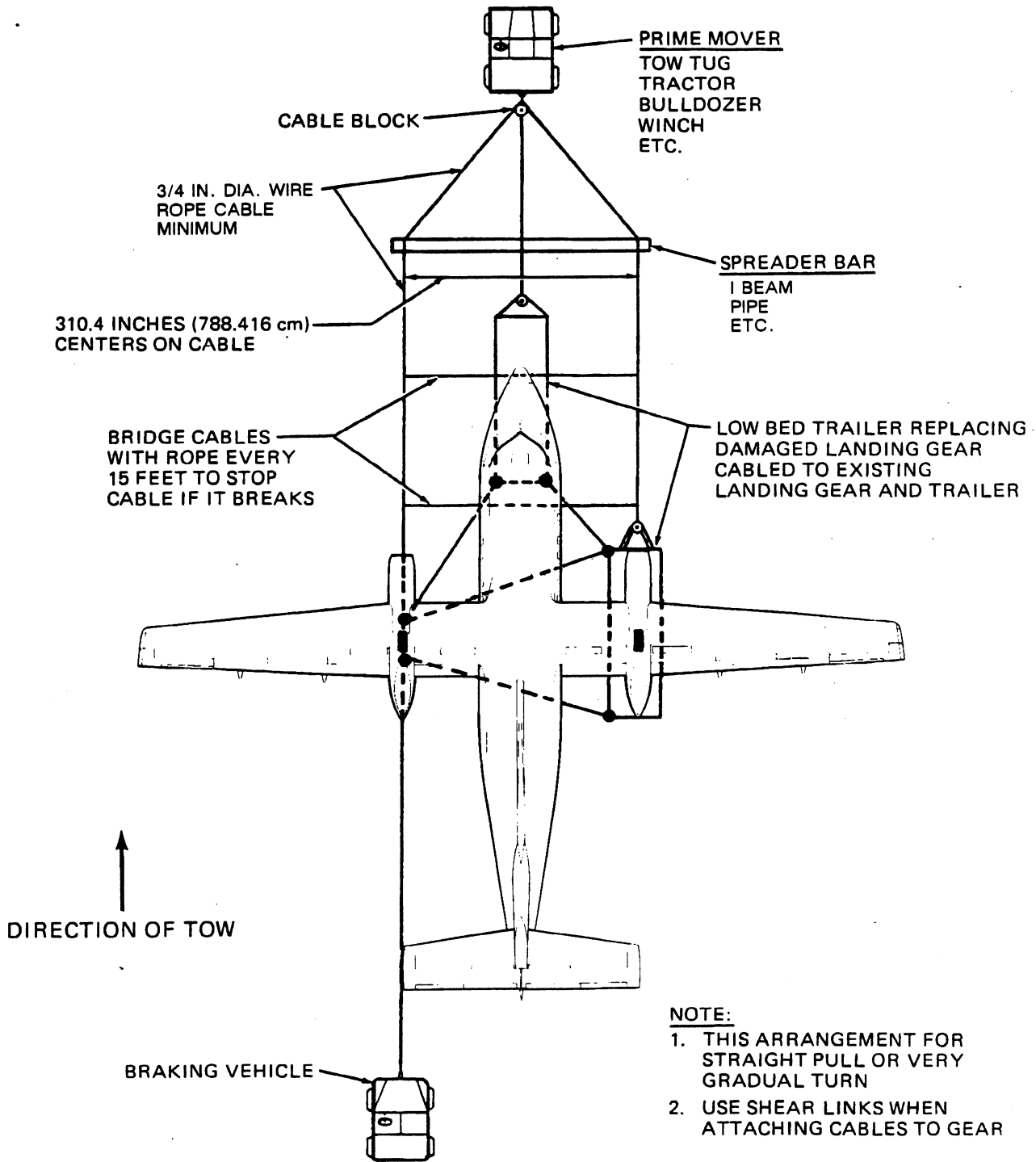

**TOW CABLE ARRANGEMENT (LOW BED TRAILERS)**

**FIGURE 1**

**4-10-00**

## DASH 8 AIRCRAFT RECOVERY

### TOWING AND WINCHING

#### 1. General

- A. Methods are described for towing and winching damage aircraft from the site of the incident, included are methods for attaching cables and ropes.
- B. Allowable limits on the landing gear for towing or winching are shown.

**WARNING:** MAXIMUM TOWING FORCE IS 7052 IB. (3198.8 KG.) LIMIT PER MAIN GEAR.

**CAUTION:** ENSURE THAT LANDING GEAR GROUND LOCK PINS ARE INSTALLED WHERE POSSIBLE. LIMIT AIRCRAFT TOWING SPEED TO 5 M.P.H. MAXIMUM.

**CAUTION:** IT IS IMPORTANT TO BE AWARE WHEN TOWING OR WINCHING AIRCRAFT THAT WHEN NOT PULLING ON ALL GEARS, THE GEAR NOT RECEIVING THE PULL CAN BE SUBJECTED TO HIGH DRAG LOADING IF IT SHOULD ENCOUNTER AN OBSTRUCTION. FOR THIS REASON ALL GEARS WHICH ARE OFF THE PAVEMENT SHOULD BE TOWED AT THE SAME TIME IF POSSIBLE.

#### 2. Towing From Nose Landing Gear (Figure 3)

Refer to Maintenance Manual PSM 1-8-2 or PSM 1-83-2 for towing information.

- A. Check nose shock strut inflation, do not tow aircraft if strut is deflated or is extended above 3 inches (7.62 cm).

**NOTE:** If strut is extended beyond 3 inches (7.62 cm), the C.G. is too far aft or strut is over inflated (Figures 4 and 5).

- B. If the aircraft is supported on its own landing gear (nose and main) and a suitable treadway from the aircraft to a hard surface (runway or taxiway) has been prepared it may be possible to tow and/or push from the nose gear towing spools in the normal manner.

**WARNING:** IF NOSE GEAR HAS SUSTAINED DAMAGE TOW AIRCRAFT FROM MAIN GEAR ONLY.

- C. Care must be taken not to exceed landing gear and towbar load limits, maximum slope 2% with empty, defuelled aircraft.

#### 3. Towing or Winching From Main Landing Gear (Figure 7)

- A. If normal towing is not practical, towing from the main landing gear using ropes and tractors can be accomplished, ropes can be attached to designated sections of the landing gear assembly and to one or more tractors positioned forward or aft of the aircraft as required. Care must be taken to pad and protect the landing gear and aircraft from damage by the towing ropes.

**NOTE:** Manila ropes are adequate for the Dash 8 Aircraft.

**4-20-00**

## DASH 8 AIRCRAFT RECOVERY

**WARNING: TO AVOID PERSONNEL INJURY DO NOT GUIDE THE NOSE GEAR TOWBAR MANUALLY.**

- B. Aircraft may be towed or winched either forward or aft depending upon the circumstances, it will be necessary to guide the nose gear using a towbar attached to a tractor while the aircraft is being moved.
  - C. Shear pins in the tow ropes assembly should be used to protect the landing gear from overload conditions. Care must also be taken to avoid imposing excessive side loads on the landing gear.
  - D. Bridge ropes approximately every 15 feet (457.2 cm) to prevent rope from whipping if shear link or rope fails, personnel to stay clear of loaded tow ropes to avoid injury if rope or link fails.
  - E. When more than one vehicle is used for towing, it is a recommended arrangement to cable the tow vehicles in tandem, this arrangement prevents the seesaw action of two vehicles on the two main landing gear.
  - F. Coordinate tow vehicle(s) and/or winch(es) and slowly increase pull until aircraft starts to roll. Once roll starts, maintain movement slowly and steadily in a straight path. Turns should be made with as large a radius as possible. Back up any movement with wheel chocks to prevent rollback.
  - G. A trailing vehicle with a restraining line to the aircraft is recommended to establish a means of controlling roll when on hard surface to prevent the aircraft being towed from overtaking the towing vehicle.
  - H. If support trailer is used under nose of fuselage it should have a swivel cradle to allow for turning during towing or winching.
  - I. If towing by tractor using rope is impractical a method using winches and ropes can be utilized, winches are placed in line with main landing gear along the path direction in which the aircraft is to be moved. Winching has better controllability for speed over most surface conditions but is limited by the drum size and rope or cable length, hence, the winching vehicles have to be moved because of cable length and direction. The same precautions to avoid aircraft damage and personnel injury must be observed.
- 4. Limit Loads and Towing Angles**
- A. Figure 1 shows ground towing requirements for various towing conditions. From the chart, the draw bar pull can be determined knowing the other parameters.



## **DASH 8 AIRCRAFT RECOVERY**

- B. To use the chart, an example is included, thus:

A 31,000 lb (14062 Kg) aircraft is to be pulled up a 1 percent slope (1-unit vertical by 100 units horizontal) and over wet concrete.

Interpolate 31,000 between 30,000 and 35,000 lb aircraft weight and enter the chart at 31,000 lb (14062 Kg). Trace down to intersect the 1 percent line maintaining the same ratio between 35,000 and 30,000 lb lines. Draw a horizontal line until it intersects the wet concrete friction line ( $\mu = .57$ ). From this point, continue to the left and read on the vertical scale, 1925 lbs (873 Kg) draw bar pull. From the point read down, to Total Traction Wheel Load of 3420 lbs (1551 Kg).

- C. When towing from the nose gear, a limiting angle of 60 degrees from the centerline on either side of the aircraft is the most that the nose gear can be turned.

**Boeing Canada**  
de Havilland Division  
**DASH 8 AIRCRAFT RECOVERY**

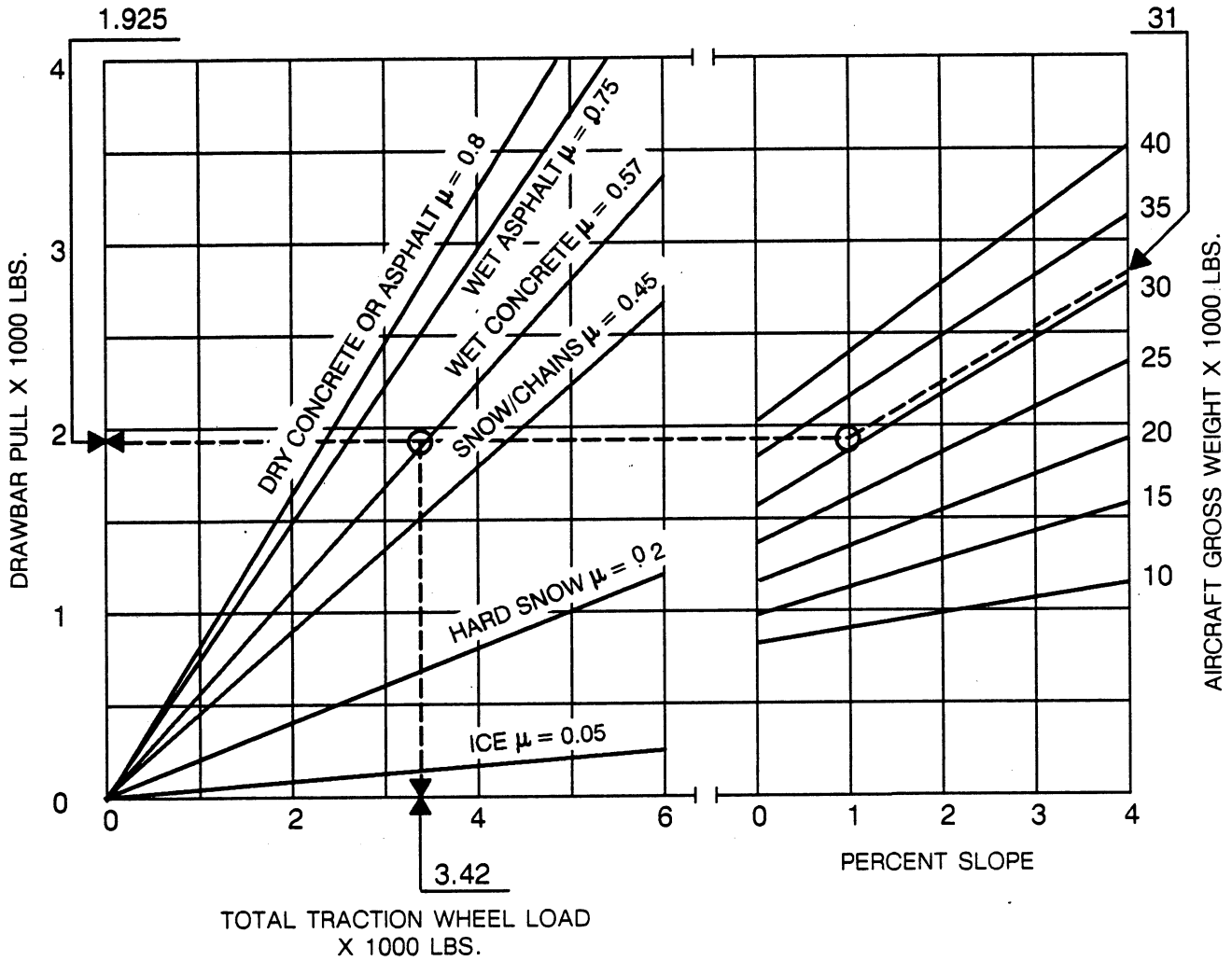

**NOTES:**

- STRAIGHT-LINE TOW
- UNUSUAL BREAKAWAY CONDITIONS NOT SHOWN
- COEFFICIENTS OF FRICTION (μ) ARE ESTIMATED FOR RUBBER-TIRED TOW VEHICLES

**GROUND TOWING REQUIREMENTS**

FIGURE 1

**4-20-00**

## DASH 8 AIRCRAFT RECOVERY

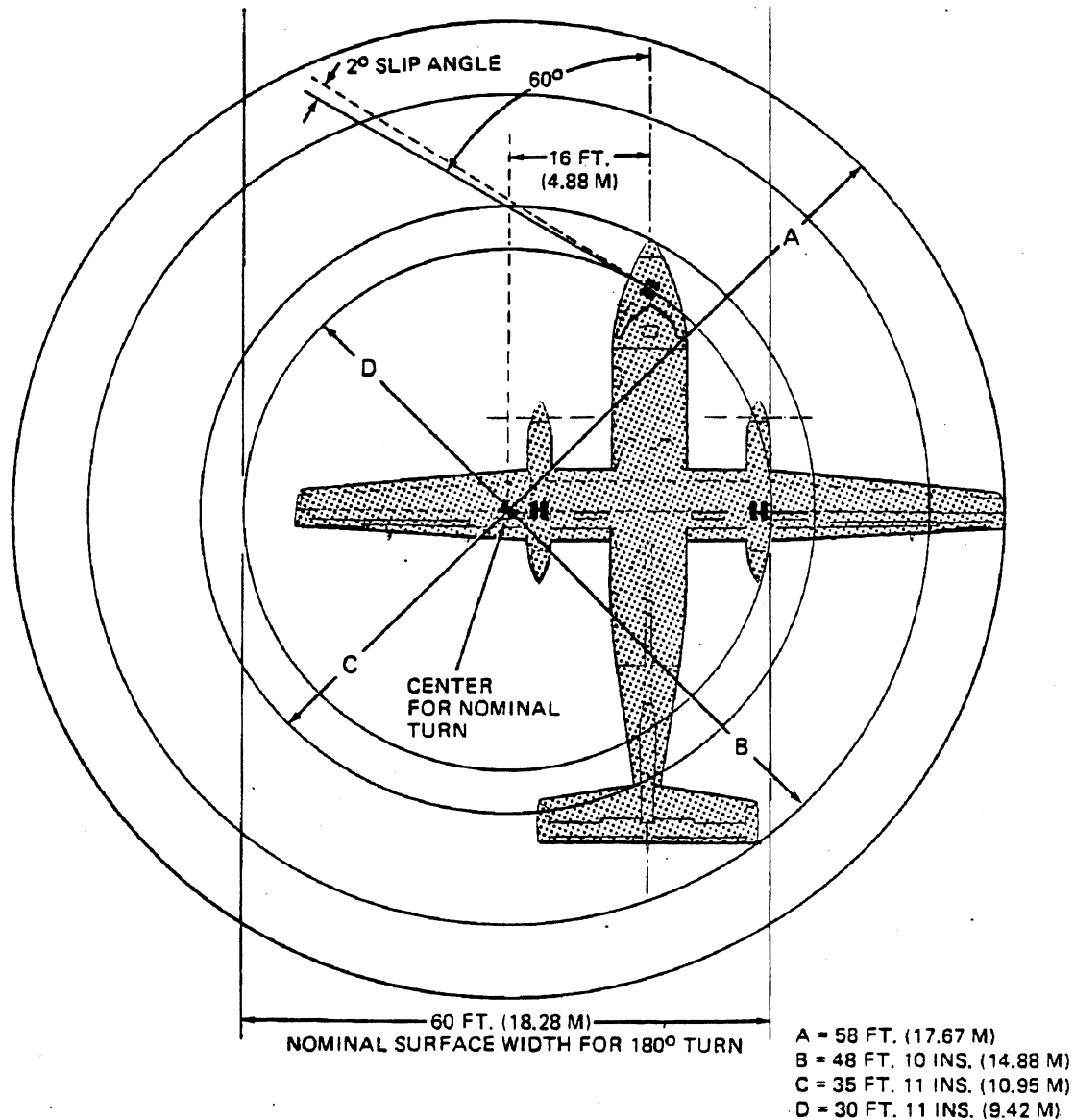

### NOTES:

1. DIMENSIONS QUOTED ARE GIVEN FOR A DRY HARD LEVEL SURFACE AT THE RECOMMENDED TIRE PRESSURES FOR A STANDARD AIRCRAFT.
2. THE NOSE WHEEL STEERING LIMIT IS APPROXIMATELY 60° LEFT AND RIGHT.
3. THE 2° SLIP ANGLE IS APPROXIMATE ONLY AND MAY VARY DEPENDING ON AIRCRAFT CONFIGURATION, LOADING AND TIRE WEAR.
4. DIMENSIONS GIVEN FOR THE MANEUVERING CLEARANCE AND TURNING RADII ARE THE MINIMUM RECOMMENDED LIMITS.

### AIRCRAFT TURNING RADII

FIGURE 2

4-20-00

PAGE 5

OCT 10/90

### DASH 8 AIRCRAFT RECOVERY

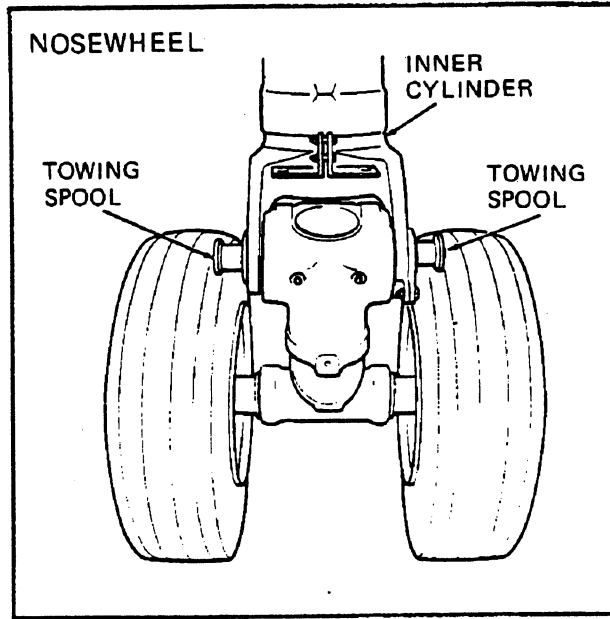

CAUTION:  
MAXIMUM NORMAL TOWING TURNING LIMITS ARE INDICATED BY PAINTED ARROWS ON BOTH NOSE LANDING GEAR DOORS (120 DEGREES EACH WAY FROM CENTER).  
AVOID DAMAGING THE NOSE GEAR – DO NOT EXCEED THE TURNING LIMITS.

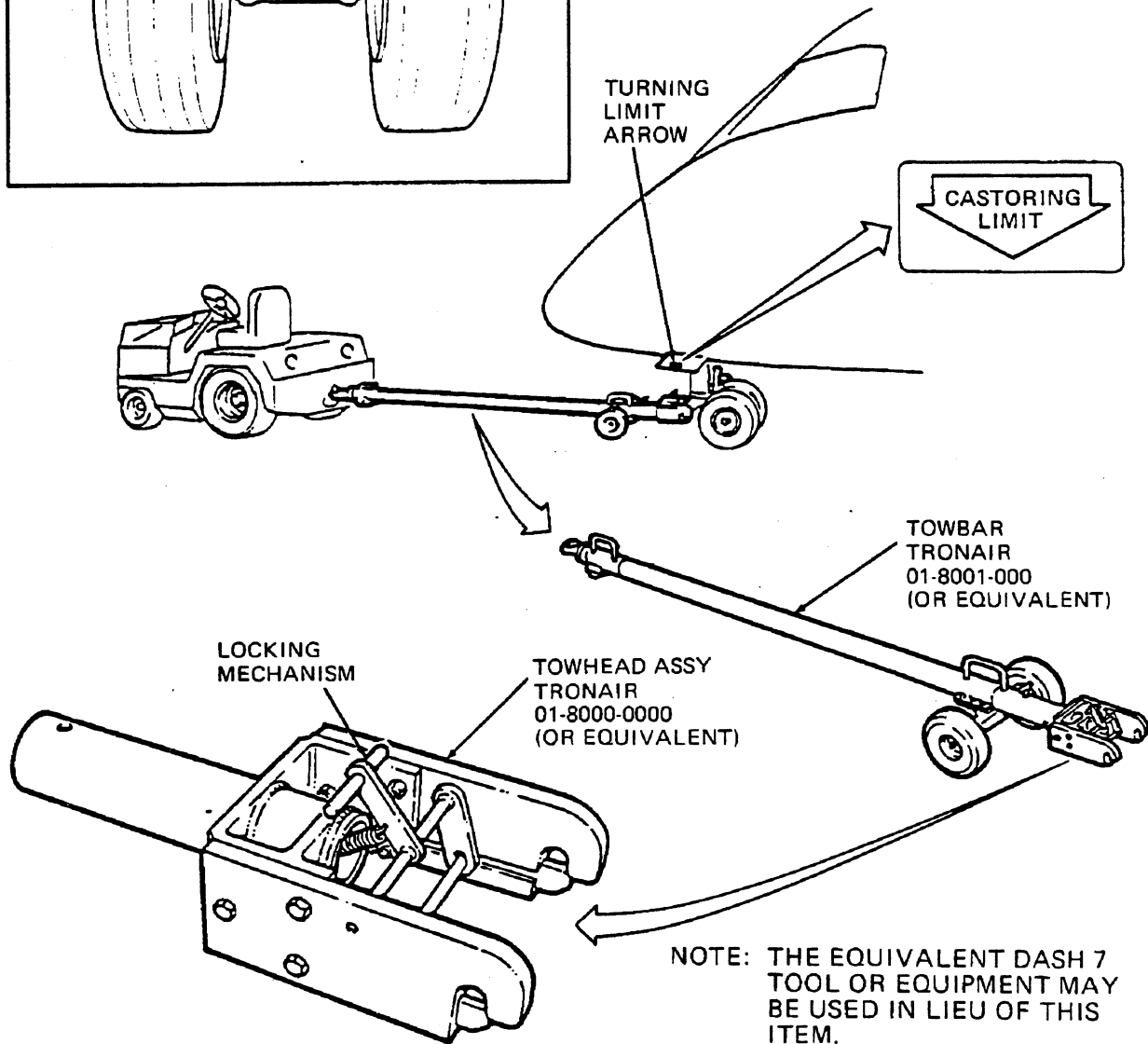

AIRCRAFT TOWING  
FIGURE 3

4-20-00

DASH 8 AIRCRAFT RECOVERY

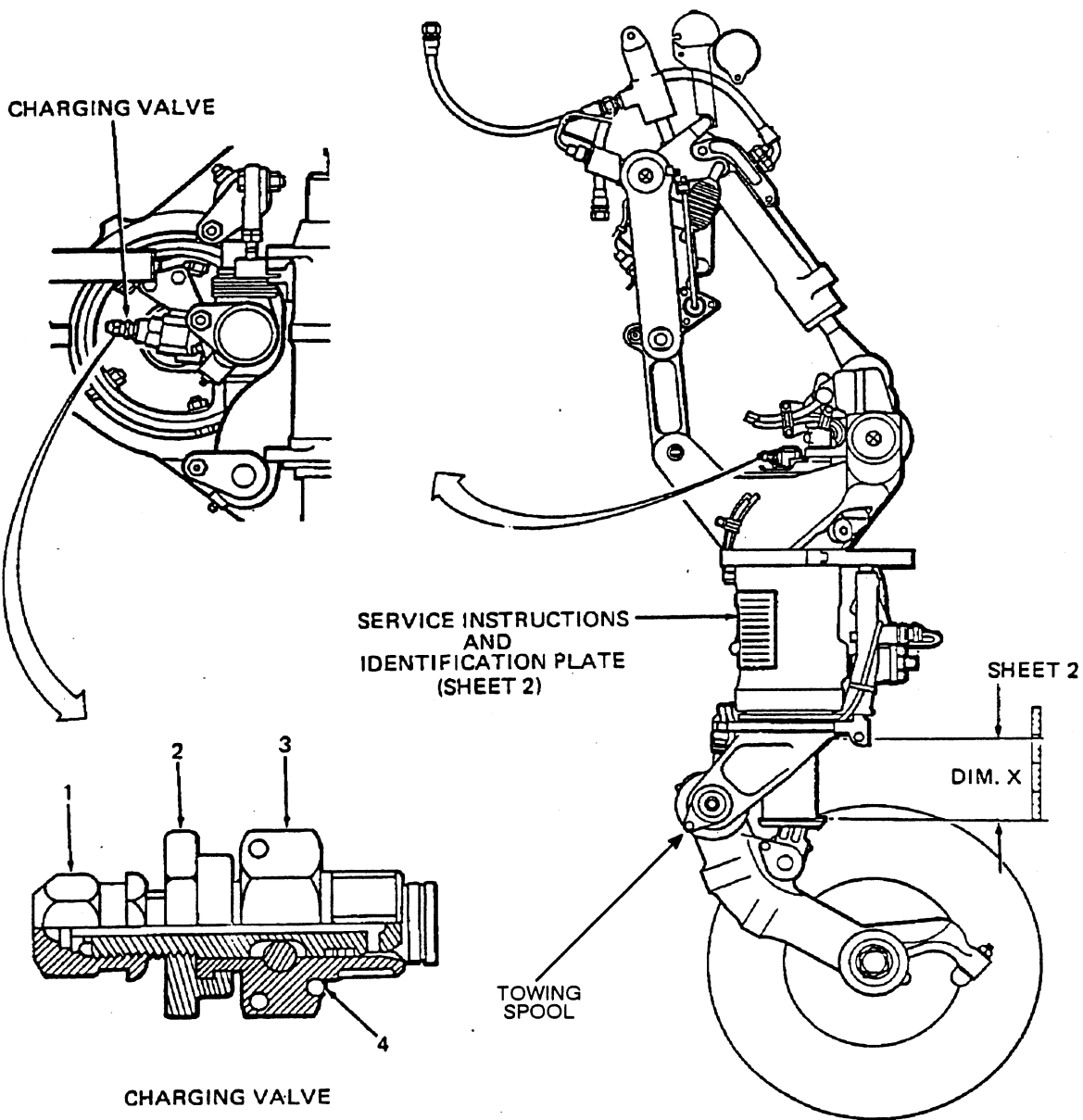

TOW ATTACH POINT AND REPLENISHING NOSE GEAR SHOCK STRUT

FIGURE 4 (SHEET 1)

4-20-00

PAGE 7

OCT 10/90

DASH 8 AIRCRAFT RECOVERY

**DOWTY**  
EQUIPMENT OF CANADA LTD.  
AJAX ONTARIO

**SHOCK STRUT ASSY  
DHC-8 NOSE GEAR**

8865-5

**SERVICE INSTRUCTIONS**

1. OPEN CHARGING VALVE TO FULLY COMPRESS STRUT
2. WITH AIRCRAFT WEIGHT ON GEAR CONNECT HYDRAULIC LINE TO CHARGING VALVE. FILL STRUT TO OVERFLOW WITH MIL-H-5606 HYDRAULIC FLUID.
3. DISCONNECT HYDRAULIC SUPPLY.
4. INFLATE STRUT WITH NITROGEN UNTIL DIMENSION 'X' IS 1.0 TO 3.0 INCHES.
5. MEASURE NITROGEN PRESSURE IN STRUT.
6. DETERMINE CORRECT DIMENSION 'X' FOR THIS PRESSURE FROM SERVICING CURVE.
7. EITHER ADD OR RELEASE NITROGEN TO OBTAIN CORRECT DIMENSION 'X'.

INFORMATION ONLY: GAS CHARGE PRESSURE WITH STRUT FULLY EXTENDED IS 290 PSI (WHEN DIMENSION 'X' IS 5.17).

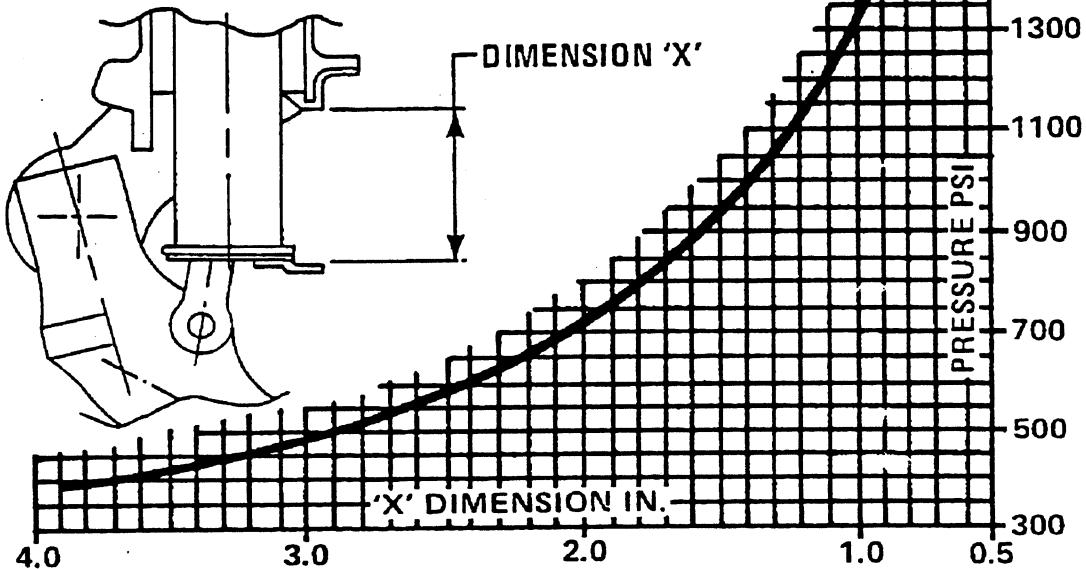

**WARNING**

RELEASE INFLATION PRESSURE IN STRUT BEFORE DISASSEMBLY

REPLENISHING NOSE GEAR SHOCK STRUT

FIGURE 4 (SHEET 2)

**4-20-00**

Boeing Canada  
de Havilland Division  
**DASH 8 AIRCRAFT RECOVERY**

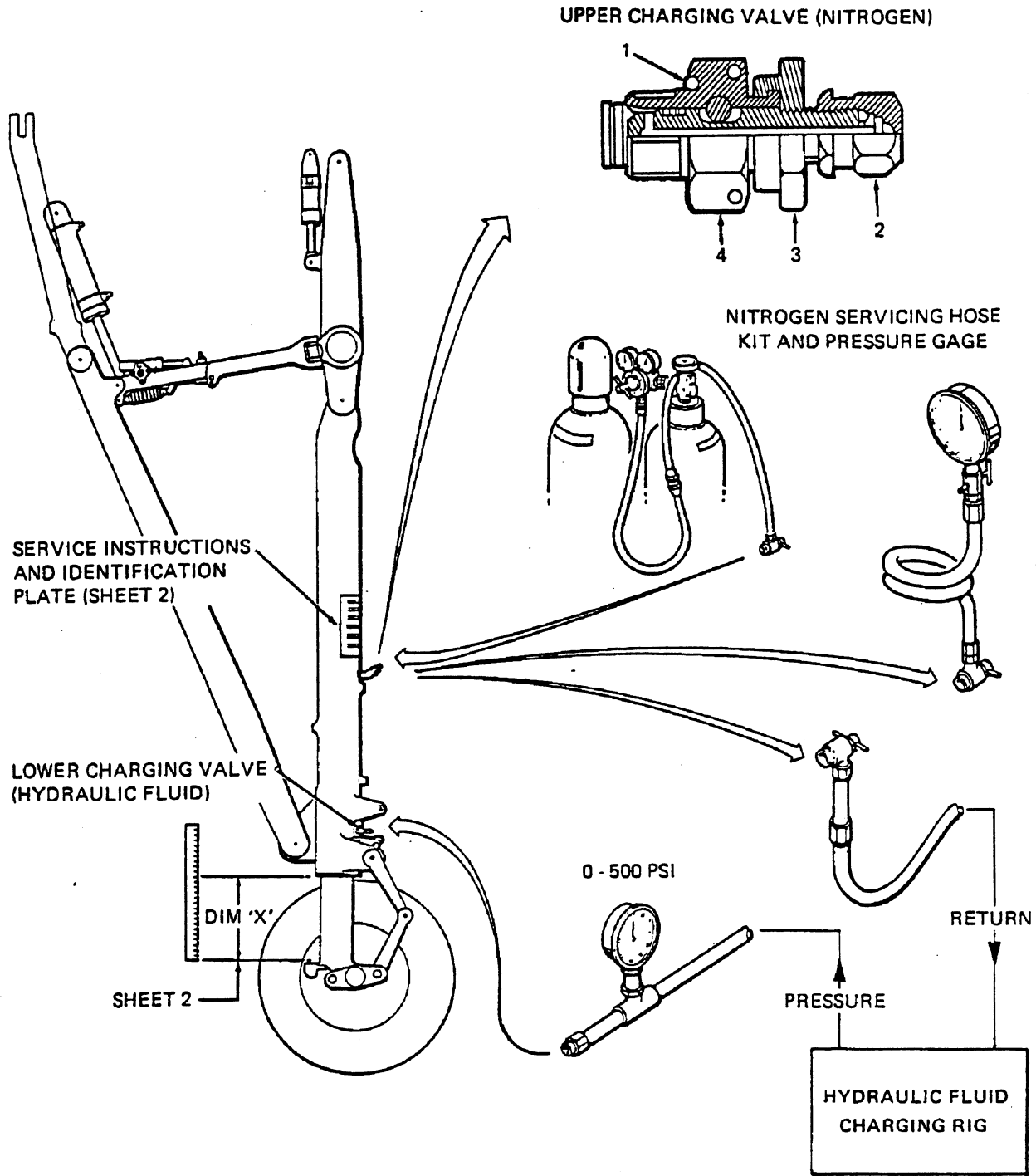

REPLENISHING MAIN GEAR SHOCK STRUT

FIGURE 5 (SHEET 1)

**4-20-00**

PAGE 9

OCT 10/90

# DASH 8 AIRCRAFT RECOVERY

**POWTY**  
CANADA LIMITED

**SHOCK STRUT ASSY  
DHC-8 MAIN GEAR**

## SERVICE INSTRUCTIONS

10154-3

THIS SEQUENCE OF ACTIONS WILL ACHIEVE THE CORRECT STATE OF THE UNIT REGARDLESS OF ITS PRIOR STATE.

1. REMOVE NITROGEN CHARGING VALVE FAIRING COVER.
2. WITH WEIGHT ON WHEELS SLOWLY OPEN NITROGEN CHARGING VALVE AND ALLOW STRUT TO FULLY COMPRESS.
3. REMOVE NITROGEN CHARGING VALVE.
4. CONNECT SOURCE OF MIL-H-5608 FLUID TO OIL CHARGING VALVE.
5. OPEN OIL CHARGING VALVE AND FILL STRUT UNTIL OVERFLOW FROM UPPER VALVE PORT IS GAS FREE.
6. CLOSE OIL CHARGING VALVE AND REMOVE OIL SOURCE.
7. REPLACE NITROGEN CHARGING VALVE.
8. APPLY NITROGEN PRESSURE UNTIL SHOCK STRUT COMMENCES TO EXTEND AND NOTE PRESSURE REQUIRED TO INITIATE THE EXTENSION.
9. IDENTIFY FROM THE CHART THE DIMENSION 'X' THAT CORRESPONDS TO THE NOTED PRESSURE.
10. ADD FURTHER NITROGEN UNTIL THE MEASURED EXTENSION IS EQUAL TO THE IDENTIFIED VALUE OF 'X'.
11. CLOSE NITROGEN CHARGING VALVE DISCONNECT GAS SOURCE AND REPLACE FAIRING COVER.

INFORMATION ONLY - GAS CHARGE WITH SHOCK STRUT FULLY EXTENDED -- 287PSI. (WHEN DIMN 'X' - 12.5")

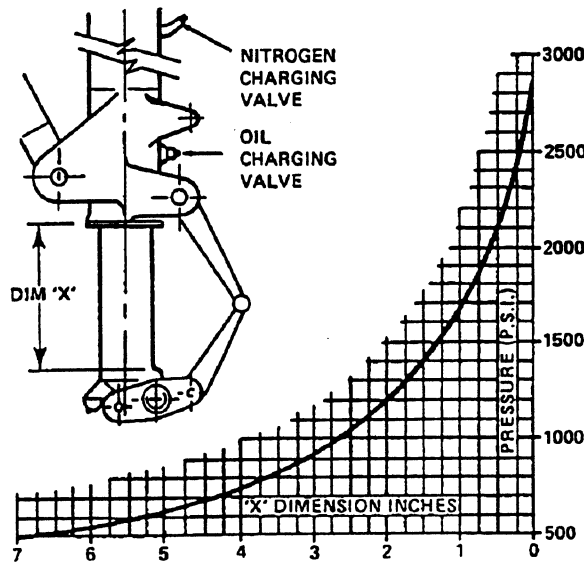

### WARNING

RELEASE INFLATION PRESSURE IN STRUT BEFORE DISASSEMBLY

REPLENISHING MAIN GEAR SHOCK STRUT

FIGURE 5 (SHEET 2)

4-20-00

PAGE 10

OCT 10/90



Boeing Canada  
de Havilland Division  
**DASH 8 AIRCRAFT RECOVERY**

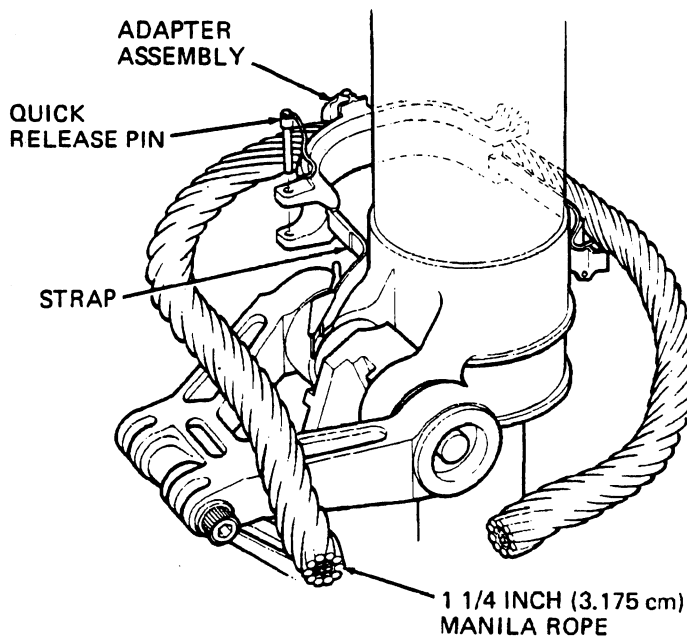
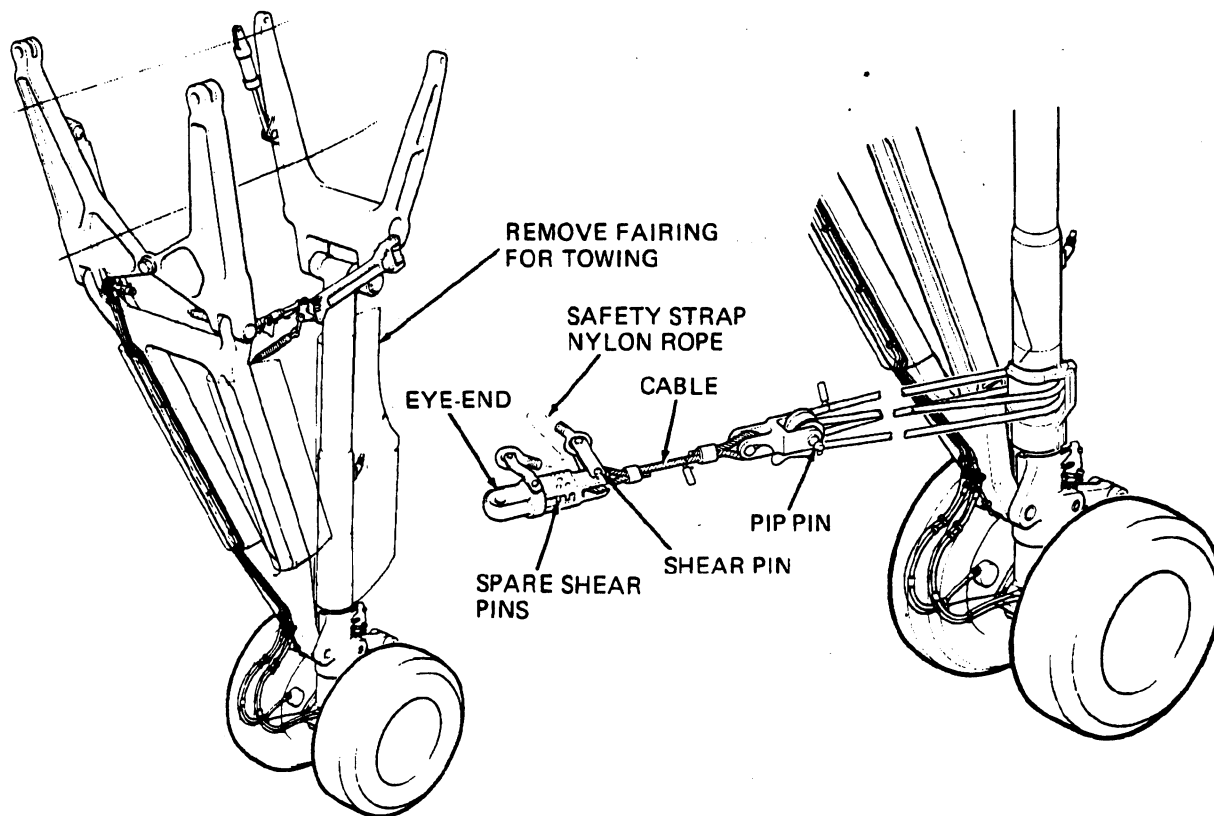

**ADAPTERS TO PROTECT MAIN LANDING GEAR**  
**FIGURE 6**

**4-20-00**

PAGE 11

OCT 10/90

DASH 8 AIRCRAFT RECOVERY

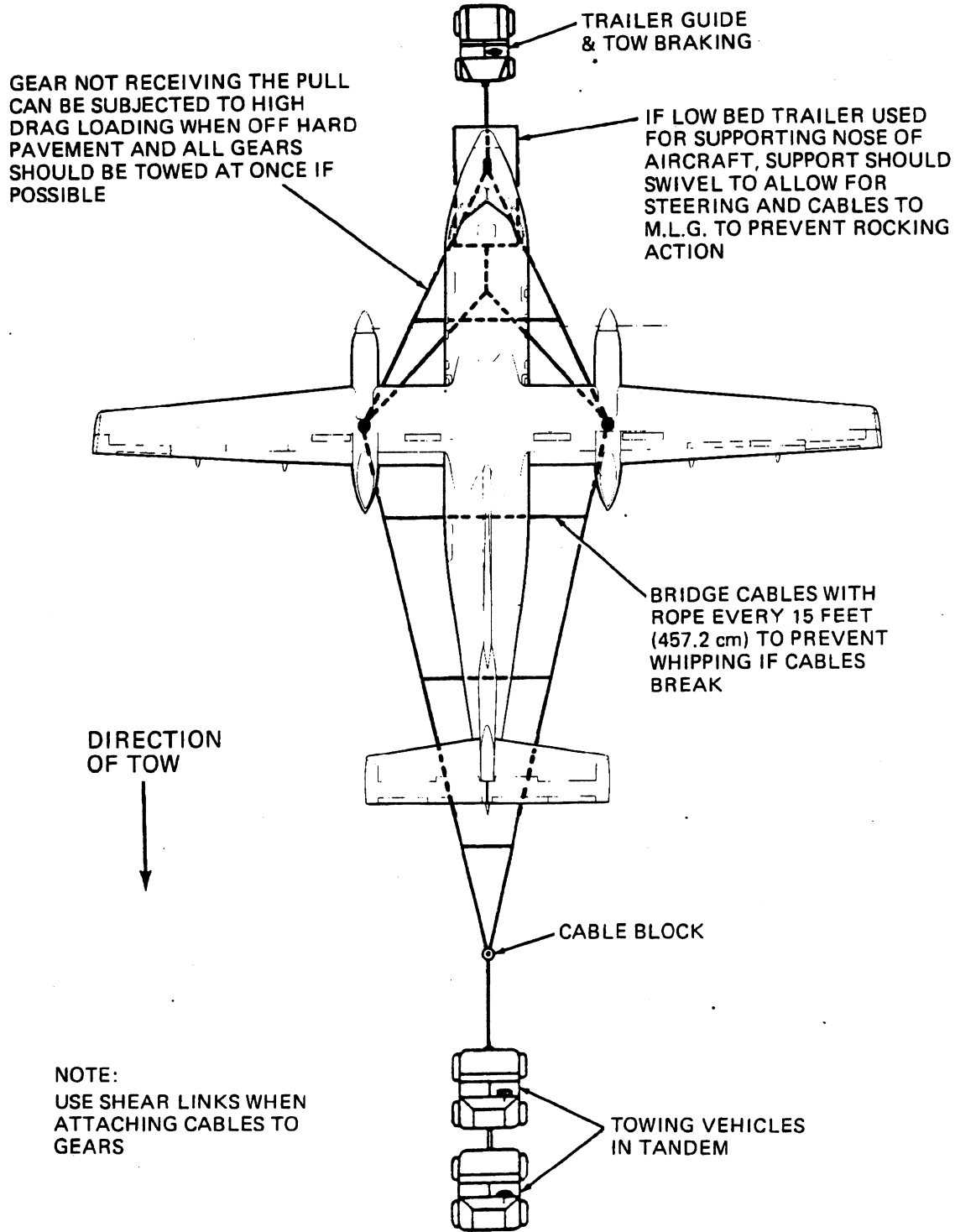

MULTI-VEHICAL TOWING ARRANGEMENT  
FIGURE 7

4-20-00

## DASH 8 AIRCRAFT RECOVERY

### RETURNING UNDAMAGED AIRCRAFT TO A HARD SURFACE

#### 1. General

- A. As a result of various circumstances an aircraft may leave the runway and become bogged down in soft soil or mud, with no damage to landing gear and airframe, but normal towing methods cannot be used to return the aircraft to a hard surface.

**NOTE:** In practically all cases of incidents the runway will be blocked and pressure will be applied to immediately clear the runway. Valuable time will be saved by planning the operation to completion before starting.

- B. Defuel tanks and off load cargo to reduce the force of friction between the wheels and the ground.

#### 2. Inspection of Aircraft

Prior to towing or winching, the aircraft must be given a HARD LANDING CHECK (refer to Maintenance Manual PSM 1-8-2) to ensure that it has not sustained structural damage that could be aggravated by towing. Attention should be given to landing gear, gear attachment points, wheels, tires and brakes.

#### 3. Aircraft Recovery Planning

- A. Plan the entire operation before starting any action.
- B. Consider terrain conditions. Check firmness of ground.
- C. Select type of platform to use (materials of construction).
- D. Determine direction aircraft will be moved.
- E. Check available equipment
- F. Provide adequate capacity tow vehicle(s).
- G. List number and type of each equipment that is required.

#### 4. Prepare Aircraft For Moving (Figure 1)

- A. Ensure down lock pin are installed in all landing gear in extended position.
- B. Bring aircraft weight to manageable level, defuel tanks and off load cargo.
- C. Lift aircraft to allow construction of boardwalk, or
- D. Build ramp to boardwalk (Figure 2).
- E. Inspect aircraft (Landing Gear)
- F. Check wheels for freedown of rotation.

#### 5. Return Aircraft to Hard Surface

- A. Attach tow ropes around main gear legs.
- B. Position tow truck/winch vehicles on runway for traction.
- C. Observe turning radius limitations.

**4-30-00**

**Boeing Canada**  
de Havilland Division  
**DASH 8 AIRCRAFT RECOVERY**

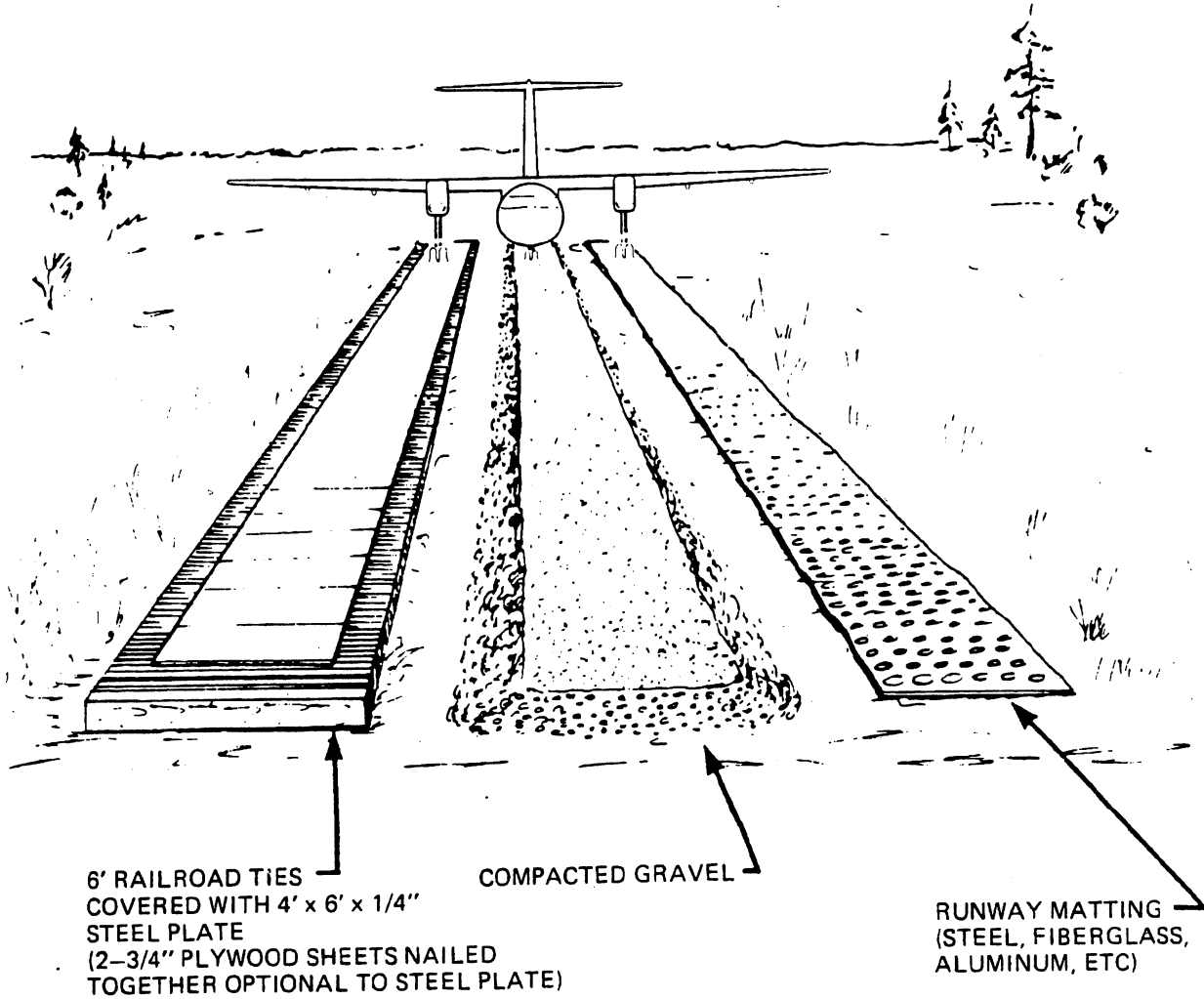

TYPICAL PREPARED SURFACES

FIGURE 1

**4-30-00**

Boeing Canada  
de Havilland Division  
**DASH 8 AIRCRAFT RECOVERY**

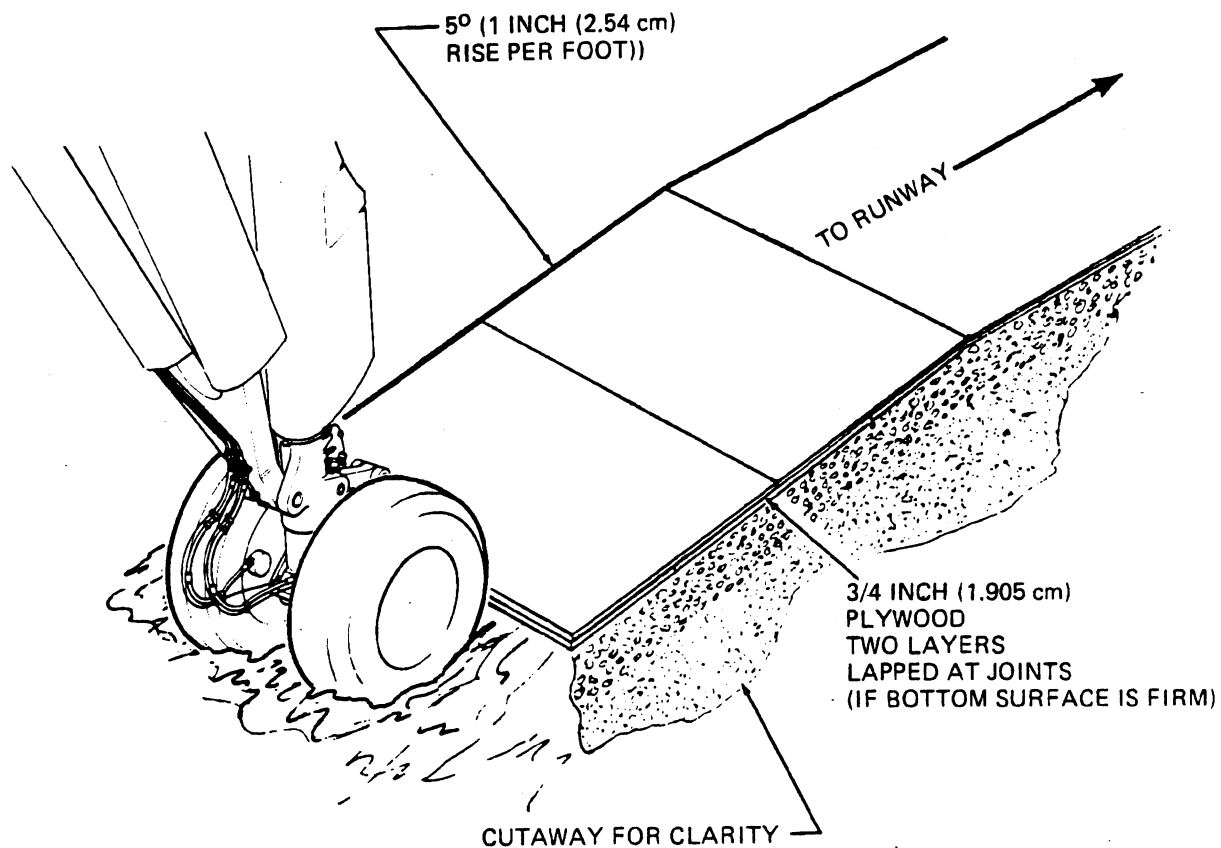

NOTE:  
OTHER MATERIALS SUCH AS RAILROAD TIES,  
1/4 INCH (0.635 cm)  
STEEL PLATE ETC. MAY BE USED

RAMP CONSTRUCTION

FIGURE 2

**4-30-00**

PAGE 3

OCT 10/90

**Boeing Canada**  
de Havilland Division  
**DASH 8 AIRCRAFT RECOVERY**

**THIS PAGE INTENTIONALLY LEFT BLANK**

**4-30-00**

**PAGE 4**

**OCT 10/90**

PSM NO. 1-8-9 AIRCRAFT \_\_\_\_\_ DASH 8 SERIES 100  
PUBLICATION AIRCRAFT RECOVERY MANUAL TEMPORARY REVISION NO. 1

Insert facing 4-10-00, Page 1.

**TOWING AIRCRAFT UTILIZING MAIN LANDING GEAR**

**REASON FOR ISSUE:**

Following review of the existing procedures and equipment used in towing the Dash-8 aircraft in recovery situations, it became apparent that further engineering investigation was required. The intent of this Temporary revision is to remove from the Aircraft Recovery Manual all references to adapters and procedures utilizing the main landing gear.

**ACTION:**

Pending further engineering investigation disregard the following:

1. Figure 1, 4-10-00, page 2.
2. Paragraph 3 on 4-20-00, page 1.
3. Figure 6 on 4-20-00, page 11.
4. Figure 7 on 4-20-00, page 12.
5. Paragraph 5, Line A on 4-30-00, page 1.

**RECORDING INSTRUCTIONS:**

This Temporary Revision will be rescinded following additional engineering investigation. At that time, new towing procedures utilizing the main landing gear will be provided.

Record this Temporary Revision in the appropriate columns of the Temporary Revision Index at the front of this manual. This Temporary Revision will be incorporated in a future revision to the Aircraft Recovery Manual.





PSM NO. 1-8-9 AIRCRAFT \_\_\_\_\_ DASH 8 \_\_\_\_\_ SERIES 100PUBLICATION AIRCRAFT RECOVERY MANUAL TEMPORARY REVISION NO. 2

Insert with page 2 facing 04-20-00, Page 12.

MULTI--VEHICLE TOWING ARRANGEMENT

REASON FOR ISSUE:

To update Multi-Vehicle Towing Arrangement illustration, Figure 7.

ACTION:

Replace the illustration in Figure 7 on page 04-20-00, page 12, with the following illustration on page 2 of TR 2.

RECORDING INSTRUCTIONS:

Record this Temporary Revision in the appropriate columns of the Temporary Revision Index at the front of this manual. This Temporary Revision will be incorporated in a future revision to the Aircraft Recovery Manual.

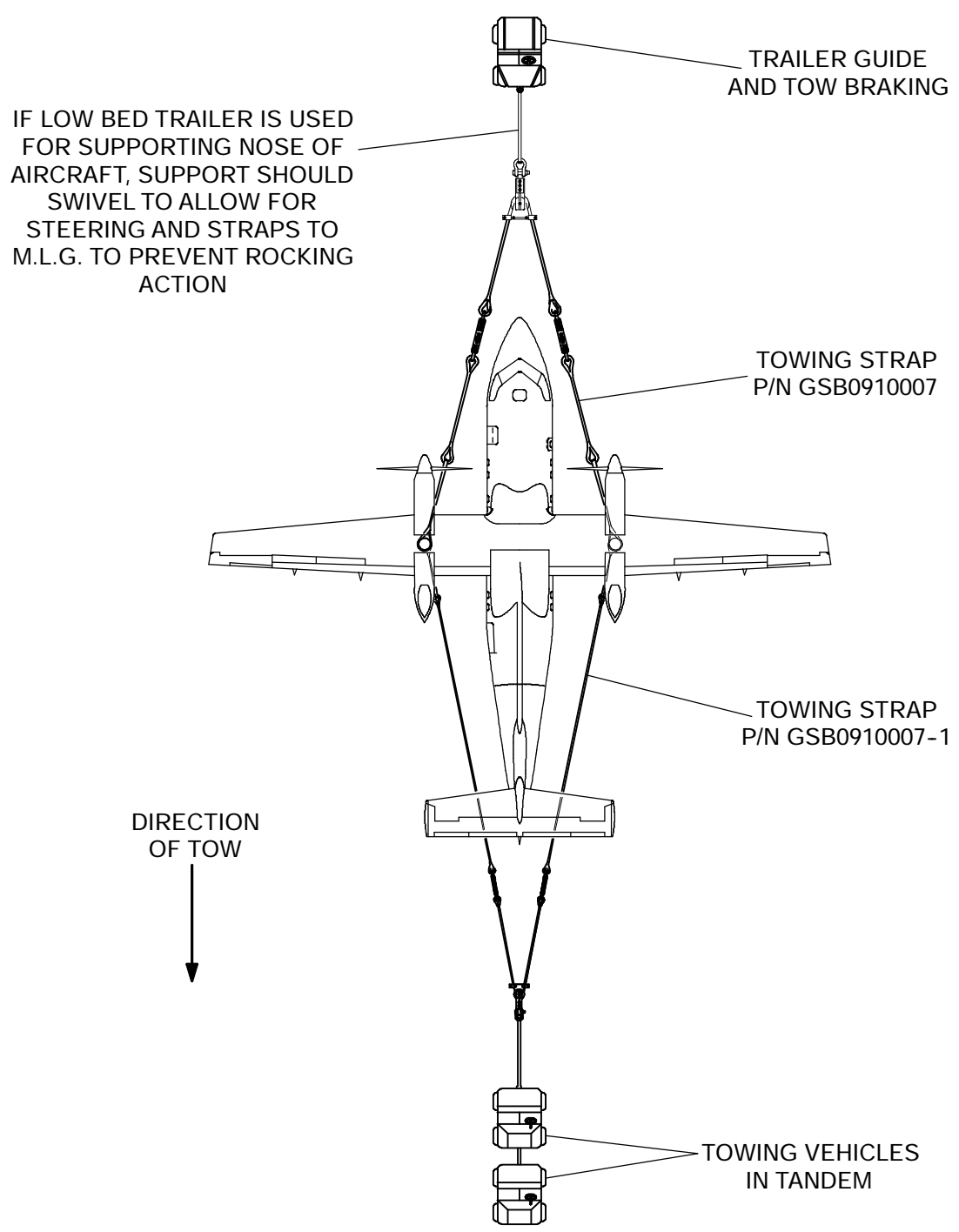

MULTI--VEHICLE TOWING ARRANGEMENT  
FIGURE 6

dar0420000\_001.dg, kms, 02/03/05

**Boeing Canada**  
de Havilland Division  
**DASH 8 AIRCRAFT RECOVERY**

**TOOLING AND EQUIPMENT**

**1. General**

The tools and equipment required for salvaging an aircraft, depend to a large extent on the nature of the incident.

Initially there is a need to ensure that support of the aircraft is obtained at the site to prevent any further damage.

Depending on the conditions at the incident site a means of salvaging the aircraft should be reviewed and an action plan formulated, the plan should cover the ultimate salvaging of the aircraft which would include the equipment needed and the preparation of the surrounding terrain to ensure removal of the aircraft.

Some of the equipment needed at the site will be construction oriented, this would be supplemented by tools and equipment which are normally available at most aircraft maintenance facilities.

Pre-planning and advance organization enhance the early recovery to the aircraft. The experiences of several airlines in aircraft recovery have been pooled together by the International Airline Technical Pool (IATP) Aircraft Recovery Working Group (ARWG). From the collective experiences of each airline, a list of equipment most likely used in aircraft recovery was compiled

The equipment most likely used in aircraft recovery is listed under General Recovery Equipment, Chapter 5-10-00. This equipment is most likely to be available from local sources. The use of this equipment is applicable to Boeing Canada de Havilland Division Aircraft.

Air transportable specialized equipment is covered in chapter 5-20-02. For quick delivery, air transportable specialized equipment is stored in strategic locations around the world. Each item of equipment is kept in readiness by the sponsor airline at each location.

**5-00-00**

PAGE 1

OCT 10/90

**Boeing Canada**  
de Havilland Division  
**DASH 8 AIRCRAFT RECOVERY**

**THIS PAGE INTENTIONALLY LEFT BLANK**

**5-00-00**

**PAGE 2**

**OCT 10/90**

## **DASH 8 AIRCRAFT RECOVERY**

### **GENERAL RECOVERY EQUIPMENT**

#### **1. General**

- A. The IATP has suggested some equipment for storage at airports to complement the specialized air transportable equipment. This equipment is shown in the General Purpose Equipment list. The General Purpose Equipment list contains heavy equipment and some common tools that are readily available from local sources.
- B. Some heavy equipment, for economic reasons, need not be physically stored at the airport. This equipment can be contracted from local builders and supply houses for use in case of emergency. The important thing is to contract this equipment ahead of time so it will be made available when needed.

#### **2. General Purpose Equipment**

- A. The General Purpose Equipment list is separate and distinct from the specialized air transportable list of equipment both prepared by the IATP.

**5-10-00**

PAGE 1

OCT 10/90

**Boeing Canada**  
de Havilland Division  
**DASH 8 AIRCRAFT RECOVERY**

Item	Description	Qty
1.	Ballast bags, 50 lbs (25 Kg.) capacity. Made of strong woven fiber to be used as platform for leveling of equipment and counterbalancing aircraft.	40
2.	Plywood sheets, 1/4 x 48 x 96 inches (0.635x121.92x243.84 cm). For placement between aircraft skin and pneumatic lift bags.	20
3.	Plywood sheets, 3/4 x 48 x 96 inches(1.905x121.92x243.84 cm). To be used as a mat over soft earth to move aircraft or equipment.	20
4.	Steel plate, 1/2 x 36 x 36 inches (1.27x91.44x91.44 cm) 1 x 48 x 96 inches (2.54x121.92x243.84 cm)	6 4
	For ground reinforcement under jacks to increase bearing area. Subsurface preparation may be required on soft earth.	
5.	Aluminum plates, 3/4 x 60 x 60 inches (1.905x152.4x152.5 cm). For easy handling when used as jack supports.	50
6.	Cribbing timber, 4 x 9-1/2 x 96 inches (10.16x24.13x243.84 cm) 4 x 9-1/2 x 126 inches (10.16x24.13x320.04 cm)	AS REQUIRED
	For platforms to support pneumatic bags of: Two (2) each 40 ton (40,000 Kg) capacity, 15 element. Five (5) each 25 ton (25,000 Kg) capacity, 15 element. Six (6) each 25 ton (25,000 Kg) capacity, 11 element.	
7.	Steel spikes (nails) for crib assembly.	200
8.	Ground reinforcement mats, 150 - 300 feet long (50-100 Meters). May be metal, plastic or fiberglass material to provide a rolling surface over the earth to permit aircraft towing.	
9.	Ground anchors, 10-15 ton capacity to provide stability and capability of tethering aircraft while lifting. May be heavy duty trucks with sand or buried timbers.	10-20
10.	Crushed rock or gravel, 13 cubic yards (10 m <sub>3</sub> ). For filling and leveling areas to allow equipment access.	
11.	Quick set concrete, 13 cubic yards (10 m <sub>3</sub> ). To provide sub-surface preparation to support jacking or other concentrated earth load situation.	

**5-10-00**

PAGE 2

OCT 10/90

**Boeing Canada**  
de Havilland Division  
**DASH 8 AIRCRAFT RECOVERY**

Item	Description	Qty
12.	Drainage pump, self-powered to remove water. 50 to 100 gpm 2 inch diameter pump, pump power supply, with 100 foot 3 inch diameter suction hose so the pump may clear the fuel vapor area.	2
13.	Crane, 10-ton (10,000 Kg.) working load, 20 feet reach (6 meters) hook height 26 - 33 feet (8-10 meters) to remove power plant. This equipment is not required if nacelle mounted engine hoist is used.	1
14.	Self propelled crane, 30 ton (30,000 Kg.) working load, 70 feet (20 meters) lift, with personnel bucket to lift nose or tail	2
15.	Multiwheel, flatbed trailer, 35 ton (35,000 Kg.) to move aircraft in lieu of landing gear.	1
16.	Steel cable assembly 1 inch (25.4 mm.) minimum diameter, complete with eyes and shear links at each end. 100 to 150 feet (30 to 50 meters). For towing or winching aircraft.	4
17.	Rope 1-1/4 inch (3.175 cm) diameter	500 Feet (152.4 Meters)
	2 inch (5.08 cm) diameter	500 Feet (152.4 Meters)
18.	Multi strand block and tackle, 5 ton (5080 Kg.) pulling capacity	2
19.	Pulling/winching units, each 10-ton (10161 Kg.) minimum capacity.	2
20.	Disposal tanks for off-loaded fuel-maximum requirement for Dash 8 aircraft.	
21.	Electric generator, gasoline powered, 5 Kva or larger	2
22.	Floodlights with cables and stands. For illumination of recovery site during night operations.	6
23.	Communication equipment, city telephone network	AS REQUIRED
24.	Megaphones with self contained amplifiers, or similar. For communicating during actual aircraft lifting and movement. Hand held transceivers may be alternate.	3

**5-10-00**

PAGE 3

OCT 10/90

**Boeing Canada**  
de Havilland Division

**DASH 8 AIRCRAFT RECOVERY**

Item	Description	Qty
25.	Area elevation map, with underground installation. For planning methods of towing and excavation.	1
26.	Workshop trailer or tent. For field office, storage shelter and eating facilities.	1
27.	Grounding rod, 10 foot (3.048 m) copperloy coated steel with 60 foot (18.29 m) cable and clip. To provide grounding of aircraft while defueling.	1
28.	Fencing material and "Danger-Keep Out", "Smoking Prohibited" signs to restrict work area to authorized personnel.	1 KIT
29.	Earth moving equipment, bulldozer or equivalent.	2
30.	Gasoline powered compressor to operate pneumatic tools	1
31.	Air powered rotary metal cutting saw for clearing of wreckage.	1
32.	Bolt cutters, sheet metal shears	1 KIT
33.	Basic tools, picks, shovels, crowbars, sledge hammers, handsaw, etc.	1 KIT
34.	Ladders, lightweight extension 20 foot (6,1 meters) 30 foot (9.14 meters)	2 2
35.	Tow tractor, 60,000 lb. (27,215 Kg.) draw bar pull	1
36.	Bulldozer, bucket loader, for excavtion	1
37..	Heater units for cold weather operation	2
38.	Tarpaulins 8 x 12 foot (2.44 x 3.66 m)	4
39.	Railroad Ties	AS REQUIRED
40.	Flashlights (Hand Held)	AS REQUIRED
41.	Used rubber tires	30
42.	Felt padding or equal	200 Sq. Ft.
43.	Mattresses (Household Type)	8

**5-10-00**

PAGE 4

OCT 10/90



**Boeing Canada**  
de Havilland Division

**DASH 8 AIRCRAFT RECOVERY**

**SPECIALIZED RECOVERY EQUIPMENT**

**1. General**

Below is a list of equipment peculiar to the de Havilland Canada Dash-8 aircraft.

<b>2. Description</b>	<b>Qty.</b>	<b>Part Number</b>
Engine Transport Stand	2 off	08-8046-0000
Engine Sling	1 off	08-8008-4000
Nacelle Mounted Engine Hoist	1 off	08-8004-000
Propeller Transport Stand Double Sided	1 off	08-8044-0000
Propeller Sling	1 off	08-8009-4000
Propeller Nut Ratchet Wrench	1 off	99-8071-6000
Auxiliary Fuel Pump Door Valve Puller	1 off	07-8066-4000
Fuel Drain Valve Tool	1 off	07-8017-6000
Auxiliary Fuel Pump Clamp Ring Wrench	1 off	07-8019-4000
Adapter - Fuselage Nose and Wing Jacks	3 off	02-8014-4000
Jack - Nose Fuselage	1 off	02-8003-0132
Jack - Wing	2 off	02-8112-0100
Tail Stand	1 off	03-8016-0000
Jack - Axle	3 off	02-8007-0132
Towhead Assembly	1 off	01-8000-0000

**5-20-00**

PAGE 1

OCT 10/90

**Boeing Canada**  
de Havilland Division  
**DASH 8 AIRCRAFT RECOVERY**

**THIS PAGE INTENTIONALLY LEFT BLANK**

**5-20-00**

PAGE 2

OCT 10/90

**DASH 8 AIRCRAFT RECOVERY**

**SPECIALIZED EQUIPMENT MANUFACTURERS**

**1. Vendor List**

- A. A list of vendors is included in this chapter representing the known manufacturers of recovery equipment. This list is provided as an informational guide only and does not represent an endorsement of a particular vendor by Boeing Canada, de Havilland Division.

**5-20-01**

PAGE 1

OCT 10/90

**Boeing Canada**  
de Havilland Division

**DASH 8 AIRCRAFT RECOVERY**

COMMUNICATIONS - HEADPHONE SYSTEM

A. David Clark  
360 Franklin Street  
Worcester, MASS. 01604

B. Willson Products Division  
P.O. Box 622  
Reading, PA. 19603

C. Sound Power Communications Inc.  
70 N. Elm Street  
Waterbury, CONN.

E. E.F. Johnson (CB) ①  
299 10th Avenue  
Waseca, MINN. 56093

F. Hy-Gain (CB) ①  
8601 N.E. Highway 6  
Lincoln, NEB 68505

COMMUNICATIONS - PORTABLE RADIO

A. Comco Co. (VHF Band)  
7811 Coral Way Suite 106  
Miami, FLA 33155

B. General Electric Co. (VHF Band)  
Communications System Division  
Box 4197  
Lynchburg, VA. 24502

C. Motorola (VHF Band)  
Communications Division  
1313 E. Algonquin Road  
Schaumburg, ILL. 60172

D. RCA (VHF Band)  
Communications System Division  
Front and Cooper Sts.  
Camden, N.J. 08102

CRANES - MOBILE

A. AMF INC. - AMF York Div.  
Whitford and Eden Roads  
York, PA 17402

B. P & H Harnischfeger Corp.  
4400 W. National Ave.  
Milwaukee, WI 53246

FISHPOLE HOIST

A. Didsbury Engineering Co.,  
Little Western Street  
Rusholme, Manchester 14  
England

B. P.F. Industries, Inc.  
9320 - 15th Ave. S.  
Seattle, WA. 98108

C. Wadell Equipment Co., Inc.  
3922 Park Avenue  
Edison, N.J. 08817

CAUTION:

① Use of Citizen Band (CB) radios is restricted in some countries.

**5-20-01**

PAGE 2

OCT 10/90

**Boeing Canada**  
de Havilland Division

**DASH 8 AIRCRAFT RECOVERY**

JACKS

- A. Malabar Manufacturing Co.  
950 Doolittle Drive  
San Leandro, CA 94577
- B. Regent Jack Mfg. Co.  
11905 Regent View Avenue  
Downey, CA 90241
- C. Columbus Jack Corp.  
1000 S. Front St.,  
Columbus, OH 43206
- D. Syncro Air Lift Corp.  
(Rise Incorporated)  
1428 Wilshire Avenue  
Santa Anna, CA 92704
- E. C.F. Taylor Commercial  
SKYHI Jacks, Ltd.  
Molly Millars Lane  
Workingham, Berkshire,  
England
- F. Hydro-Geraetebau GmbH K.G  
7616 Biberach  
Baden, West Germany
- G. Mingay Station Works  
Chigwell  
Essex, England
- H. Ste Payan S.A.  
32 Rue Delpech  
83 Toulon, France
- I. Tronair  
Aircraft Ground Support Equip.  
South 1740 Eber Road  
Holland  
Ohio 43528

FORK LIFT TRUCKS

- A. Allis Chalmers  
Material Handling Division  
21800 S. Cicero Avenue  
Matteson, ILL 60443
- B. Camet Industries Co., Inc.  
500 Lincoln St.,  
Boston, MASS 01234
- C. Clark Equipment Co.  
Industrial Truck Div.  
24th Street  
Battle Creek, MI 49015
- D. Eaton Corporation  
100 Erieview Plaza  
Cleveland, OH 44114
- E. Hyster Company  
P.O. Box 2902  
Portland, OR 97208

HAULAGE & RECOVERY EQUIPMENT

- A. J.L. Eve Construction Co.  
Station Road, Lower Heyford  
Oxfordshire, OX5 3PD,  
England

**5-20-01**

PAGE 3

OCT 10/90

**Boeing Canada**  
de Havilland Division

**DASH 8 AIRCRAFT RECOVERY**

GROUND ANCHORS

- A. A.B. Chance Company  
210 N. Allen St.,  
Centralia, MO 65240
- B. Tirfor Ltd.  
Halfway  
Sheffield  
S 19 5G2  
England
- C. Laconia Malleable Iron Co.  
Laconia, NH
- D. R.F.D. Company Ltd.  
Godalming  
Surrey, England

LANDING GEAR DOLLY

- A. Ground Support Engineering  
5095 N.W. 79th Avenue  
Miami, FL 33166
- B. Synchro Airlift Corp.  
1500 N. Glassel  
Orange, CA 92667
- C. Tronair  
Aircraft Ground Support Equip.  
South 1740 Eber Road  
Holland  
Ohio 43528

LIFTING BAGS

- A. B.F. Goodrich  
Dept. 0751  
5005 Main St.,  
Akron, OH
- B. Goodyear Tire & Rubber Co.  
Aviation Products Div.  
1144 E. Market St.,  
Akron, OH 44316
- C. R.F.D. Company Ltd.,  
Godalming  
Surrey, England
- D. Vepro/USA  
P.O. Box 1062  
Coraopolis, PA 15108  
or:  
Vetter Produktions-GmbH  
Blatzheimer StraBe  
5352 Zuelpich  
West Germany

LIFTING SLINGS

- A. Cambridge Wire Cloth Co.  
Cambridge, MD 21613
- B. Tubbs Cordage Co.  
415 S. Fidalgo St.,  
Seattle, WA 98108
- C. Yacht & Commercial Rigging Co.  
Twickenham  
Middlesex, England

**5-20-01**

PAGE 4

OCT 10/90

**Boeing Canada**  
de Havilland Division  
**DASH 8 AIRCRAFT RECOVERY**

NOSE LIFT DOLLY

- A. Hydro-Geraetebau GMBH  
7616 Biberach  
Baden, West Germany
- B. Mercer - Robinson  
Div. Squibb Machine &  
Tool, Inc.  
P.O. Box 412  
Easton, PA 18043

TENSIONING DEVICES

- A. Griphoist Inc.  
331 Littlefield Ave. S.  
San Francisco, CA 94080
- B. Tirfor Ltd.  
Halfway  
Sheffield  
S 19 5G2  
England

PUMP - WATER & HOSE

- A. Peabody-Barnes  
651 N. Main St.,  
Mansfield, OH 44902

TRANSPORTERS - DISABLED AIRCRAFT

- A. UBM Engineering Ltd.  
Lower William St.,  
Northam Southampton  
England 509 2DN

REMOVABLE MATTING

- A. J.L. Eve Construction Co., Ltd.  
Trakway Div.  
Station Road, Lower Heyford  
Oxfordshire, OX53PD, England
- B. Air Logistics Corporation (MO Mat)  
3600 East Foothill Blvd.,  
Pasadena, CA 91109
- C. R.F.D. Company, Ltd.  
Godalming  
Surrey, England
- D. Martin Marietta  
Aluminum Division  
19200 S. Western Avenue  
Torrance, CA 90509

- B. Regent Jack Mfg. Co.  
11905 Regentview Ave.,  
Downey, CA 90241
- C. Air International Recovery  
1617 Terminal Avenue  
San Jose, CA 95100

**5-20-01**

PAGE 5

OCT 10/90

**Boeing Canada**  
de Havilland Division  
**DASH 8 AIRCRAFT RECOVERY**

VEHICLES

- A. Air International Recovery  
1617 Terminal Avenue  
San Jose, CA 95100
  
- B. Field Aircraft Service, Ltd.  
Heathrow Airport  
Hounslow  
Middlesex, England
  
- C. UBM Hover System Limited  
Lower William Street  
Northam  
Southampton, England

TENSION MEASURING DEVICES

- A. Acme Scale Co.  
5303 Adeline St.,  
Oakland, CA.

**5-20-01**

PAGE 6

OCT 10/90



**DASH 8 AIRCRAFT RECOVERY**  
**SPECIALIZED TRANSPORTABLE EQUIPMENT**

**1. Air Transportable Equipment**

- A. Several airlines have joined together to form the International Airline Technical Pool (IATP). Its purpose is to make some essential aircraft recovery equipment available for shipment to any place in the world at short notice. This organization has identified the minimum equipment for use on most aircraft recovery operations. In kit form, these items are air transportable and are presently stored in eleven (11) strategic locations around the world for quick delivery. These place are: Bombay, India; Honolulu, U.S.; Johannesburg, South Africa; London, England; Los Angeles, U.S.; New York, U.S.; Chicago, U.S.; Paris, France; Rio de Janeiro, Brazil; Sydney, Australia; and Tokyo, Japan.
- B. This equipment is owned by the member airlines and is shared through the organization. Non-member airlines can also avail themselves of the equipment on a rental fee basis. Custodians, their locations and contact are shown in figure 1.
- C. These kits are maintained, kept in a state of readiness and ready for shipment by the custodian airline in each locations.
- D. While the kit was developed for the older model aircraft, the equipment is usable on Dash 8. There are no kits developed at this time specifically for the Dash 8 aircraft.
- E. Similar equipment is kept in some military installations and airports not included in the locations mentioned previously.

**2. Air Transportable Recovery Kit**

- A. The recovery kit contains the necessary equipment to raise an aircraft which has made a landing with one or more of its landing gears retracted and/or may have run off the runway.
- B. A typical kit consists of the following:

Qty 8	12 ton (12200 Kg) pneumatic lift bags and repair kit
Qty 3	portable air compressor, 50 CFM (1,415 liters per min.), 1 to 4 psi (.28 Kg/sq. cm.), manifolds and hoses.
Qty 8	mattresses (or similar material for padding)
Qty 10	earth screw anchors
Shts 24	plywood, 1/4 x 48 x 96 inches (0.635 x 121.92 x 243.84 cm)
Ft. 500	1 inch (2.54 cm) diameter rope
Qty 4	come-along or ratchet hoist, 2-ton (2032 Kg) capacity
Qty 3	short-stroke aircraft axle or screw type jacks - 30 to 50 ton (30482 to 50803 Kg) capacity
Qty 6	steel plates 1/2 x 24 x 24 inch (1.27 x 60.96 x 60.96 cm)
Qty 1	light alloy access ladder, 15 foot (4.572 meters)
Qty 1	electric power unit for emergency lighting - 5 Kw or larger
Qty 4	floodlights, lamp stands, leads and junction boxes and 50 foot (15.24 meter) extension.

Plus other specialized equipment the custodian airline may provide.

**Boeing Canada**  
de Havilland Division

**DASH 8 AIRCRAFT RECOVERY**

DESIGNATED AIRCRAFT RECOVERY CO-ORDINATORS  
AIRLINE POOLING ARRANGEMENTS

COUNTRY City/Airport	Provider Airline	Address		
		Site Code	Telephone	Contact
AUSTRALIA Sydney/Kingsford South International	Qantas	SYDEEQF SYDEJQF SYDWWQF	669-0111 669-7961/2	Pooling Co-ordinator
BRAZIL Rio de Janeiro/Galeao	Varig Airlines	GIGMDRG	393-3000 Ext. 216 or 393-5088	Line Stations Maintenance Superintendent
FRANCE Paris/Orly	Air France	PARHUAF ORYJRAF	675-5809	Chef de la Division d'entretien en ligne, Service du traitement de l'avion en escale
INDIA Bombay/Bombay	Air India	BOMBEBAI BOMEDAI BOMEMAI	535461 Ext. 212	Engineering Manager, Materials and Facilities
JAPAN Tokyo/Narita International	Japan Air Lines	NRTMNJL	(0476) 32-4135	Assistant General Manager, Maintenance Supplies Department
SOUTH AFRICA Johannesburg/Jan Smuts	South African Airways	JNBEHSA JNBMPSA	978-3303 978-3603 978-3703	Manager, Line Maintenance and Production Superintendent
UNITED KINGDOM London/Heathrow	British Airways	LHRKEBA	750-7465 750-7342	Fleet Maintenance Superintendent (Production Planning)

TOOLING AND EQUIPMENT  
FIGURE 1

**5-20-02**

**Boeing Canada**  
de Havilland Division

**DASH 8 AIRCRAFT RECOVERY**

DESIGNATED AIRCRAFT RECOVERY CO-ORDINATORS  
AIRLINE POOLING ARRANGEMENTS (Cont'd)

COUNTRY City/Airport	Provider Airline	Address		
		Site Code	Telephone	Contact
UNITED STATES New York/John F Kennedy International	Pan American World Airways	NYCMYPA	(212) 632-5266	Shift Foreman
Chicago/O'Hare	American Airlines	ORDMMAA	(312) 686-4400	Foreman
Honolulu/Honolulu International	United Airlines	HNLMMUA	(808) 836-5333 (808) 836-5332	Shift Foreman
Los Angeles/ Los Angeles International	Trans World Airlines	LAXMFTW	(213) 646-4417 (213) 646-8909	Manager A/C Maintenance

TOOLING AND EQUIPMENT  
FIGURE 1

**5-20-02**

**Boeing Canada**  
de Havilland Division  
**DASH 8 AIRCRAFT RECOVERY**

**THIS PAGE INTENTIONALLY LEFT BLANK**

**5-20-02**

PAGE 4

OCT 10/90

## **DASH 8 AIRCRAFT RECOVERY**

### **EQUIPMENT AVAILABILITY**

#### **1. World Wide Directory**

- A. In 1978, The Boeing Company conducted a survey among the world's airlines covering basic equipment used in the recovery of disabled aircraft. This information is compiled to assist airlines in planning and preparation of their aircraft recovery operations.
- B. The survey was limited to 3 items: pneumatic lifting bags, recovery jacks and lifting slings. It does not include all available equipment in each location nor does it cover all locations.

#### **2. Local Sources**

Some sources of heavy equipment that can be drawn from the local area are:

construction companies	military bases
road and building contractors	railroad company
shipyard and loading dock	logging companies
electrical power company	foundries
oil drilling companies	bus company garages
heavy equipment rental houses	machine shops
telephone companies	manufacturing companies

**5-20-03**

PAGE 1

OCT 10/90

**Boeing Canada**  
de Havilland Division  
**DASH 8 AIRCRAFT RECOVERY**

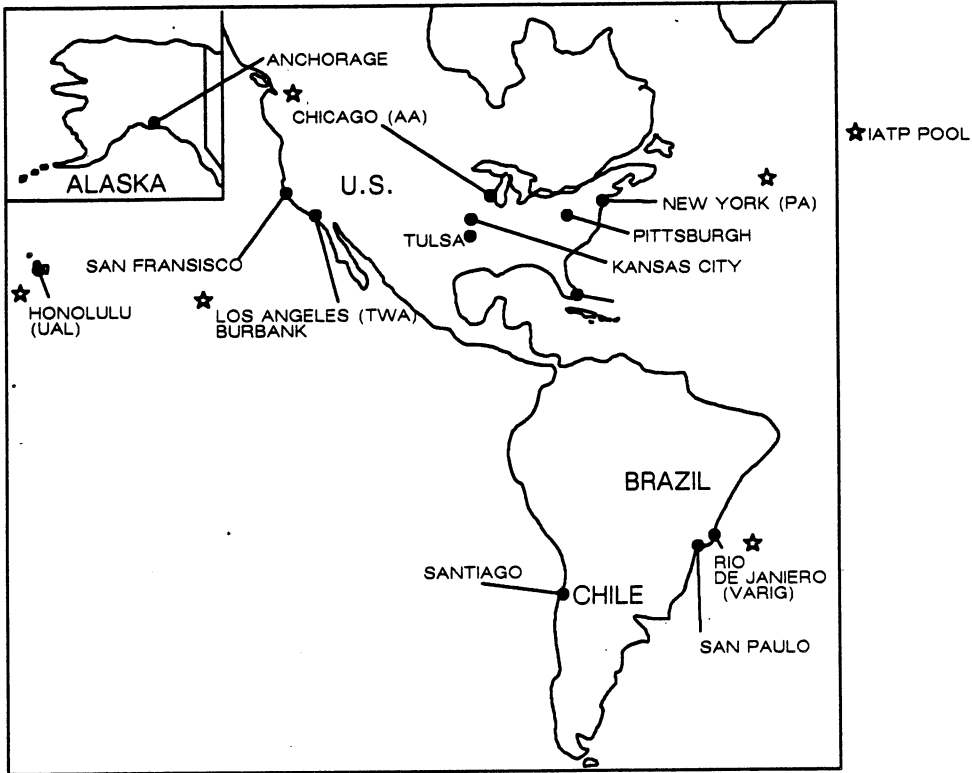

WORLDWIDE DIRECTORY OF AIRCRAFT RECOVERY  
EQUIPMENT - NORTH & SOUTH AMERICA & HAWAII

**5-20-03**

PAGE 2

OCT 10/90

**Boeing Canada**  
de Havilland Division  
**DASH 8 AIRCRAFT RECOVERY**

LOCATION	CONTROLLING AGENCY	AIRBAGS			RECOVERY JACKS			LIFTING SLINGS		
		QTY	DESCRIP/ CAP.	MFR	QTY	DESCRIP/ CAP.	MFR	QTY	DESCRIP/ CAP.	MFR
ANCHORAGE, ALASKA	NORTHWEST AIRLINES		-----		1 SET	MAINT. JACKS		-----		
HONOLULU, HAWAII	*UNITED AIRLINES	6	25 TON	B.F. GOODRICH	2	JACKS RECOVERY 30-140 IN LIFT	REGENT MOD. 8502	-----		
	NORTHWEST AIRLINES		-----		1 SET	MAINT. JACKS	REGENT	-----		
SAN FRANCISCO, CALIF.	PAN AM		-----		1 SET	MAINT. JACKS		-----		
	UNITED AIRLINES	6 3	25 TON 12 TON	B.F. GOODRICH		-----		BODY SLING 45 TON LDG GEAR SLING 30 TON BODYSLING 14 TON		TWA
LOS ANGELES, CALIF.	*TRANSWORLD AIRLINES	6	25 TON 13 ELEMENT	B.F. GOODRICH	2	100 TON RE- COV. 28-140 IN LIFT	REGENT MOD. 8502		WIDE-BODY SLING 15 TON	
PITTSBURGH PENN.	U.S. AIR	4	29M TONS 305 CM	VEPRO						
		2	29M TONS 245 CM							
BURBANK, CALIF	LOCKHEED AIRCRAFT CORP.	1			1	80 TON RECOV. 30-140 IN LIFT	MALA -BAR MOD. 8207			

\*IATP POOL

WORLDWIDE DIRECTORY OF AIRCRAFT RECOVERY  
EQUIPMENT - NORTH & SOUTH AMERICA & HAWAII

**5-20-03**

PAGE 3

OCT 10/90

**DASH 8 AIRCRAFT RECOVERY**

LOCATION	CONTROLLING AGENCY	AIRBAGS			RECOVERY JACKS			LIFTING SLINGS		
		QTY	DESCRIP/ CAP.	MFR	QTY	DESCRIP/ CAP.	MFR	QTY	DESCRIP/ CAP.	MFR
CHICAGO, ILLINOIS	*AMERICAN AIRLINES	6	25 TON	B.F. GOODRICH	2	80 TON RECOV. 30-140 IN LIFT	MALA -BAR MOD. 8264	1	SLING ASSY 45 TON OHME65B00002	BOE-ING
	UNITED EASTERN	25	12 TON		2 4	60 TON 50 TON				
KANSAS CITY, MISSOURI	TWA		-----			-----		1	SLING 15 TON	TWA
ATLANTA, GEORGIA	DELTA AIRLINES		-----			MAINT. JACKS			-----	
NEW YORK, N.Y.	*PAN AM (RECOV. KIT CUSTODIAN)	12	25 M TONS	RFD	FULL SETS 3	JACKS 80 TON RECOV. 30-140 IN LIFT	MALA -BAR MOD. 8207		UNIVERSAL 50,000 LBS. CAPACITY	
	UNITED AIRLINES		-----			MAINT. JACKS		1	BODY SLING BODY SLING	
MIAMI, FLORIDA	AMERICAN AIRLINES	4	12 TONS			MAINT. JACKS			BODY SLING	
	TRANS WORLD AIRLINES		-----			MAINT. JACKS			2 BODY SLINGS	
	EASTERN AIRLINES	11	12 TONS		3	80 TON RECOV.	MALA -BAR MOD. 8272	1	WIDE BODY SLING 20,000 LBS. CAPACITY	

\*IATP POOL



DASH 8 AIRCRAFT RECOVERY

LOCATION	CONTROLLING AGENCY	AIRBAGS			RECOVERY JACKS			LIFTING SLINGS		
		QTY	DESCRIP/ CAP.	MFR	QTY	DESCRIP/ CAP.	MFR	QTY	DESCRIP/ CAP.	MFR
RIO DE JANEIRO, BRAZIL	*VARIG AIRLINES	6	25M TONS 11 ELEMENT	RFD TYPE "D" RFD TYPE "F"	2	80 TON RECOV. 30-140 IN	MALA -BAR MOD. 8207			
		2	40M TONS 15 ELEMENT		2	50 TON 6-42 IN LIFT	HY- DRO- LITE MOD. 650		---	
SAO PAULO, BRAZIL	VASP VARIG AIR FORCE BASE		---			MAINT. JACKS			---	
SANTIAGO, CHILE	LAN CHILE				2	100 TON	REGENT 8517-101			
					1	30 TON	REGENT 8517-100			
					4	45 TON	COLUMBUS 5060-15			
					1	20 TON	MALABAR			
	LADECO				2	40 TON				
					1	25 TON				
	AIRPORT AUTH S.E.J. DEPT.	2	25M TONS MOD. G							
		4	25M TONS MOD. H							

\*IATP POOL

WORLDWIDE DIRECTORY OF AIRCRAFT RECOVERY  
EQUIPMENT - NORTH & SOUTH AMERICA & HAWAII

5-20-03

**Boeing Canada  
de Havilland Division  
DASH 8 AIRCRAFT RECOVERY**

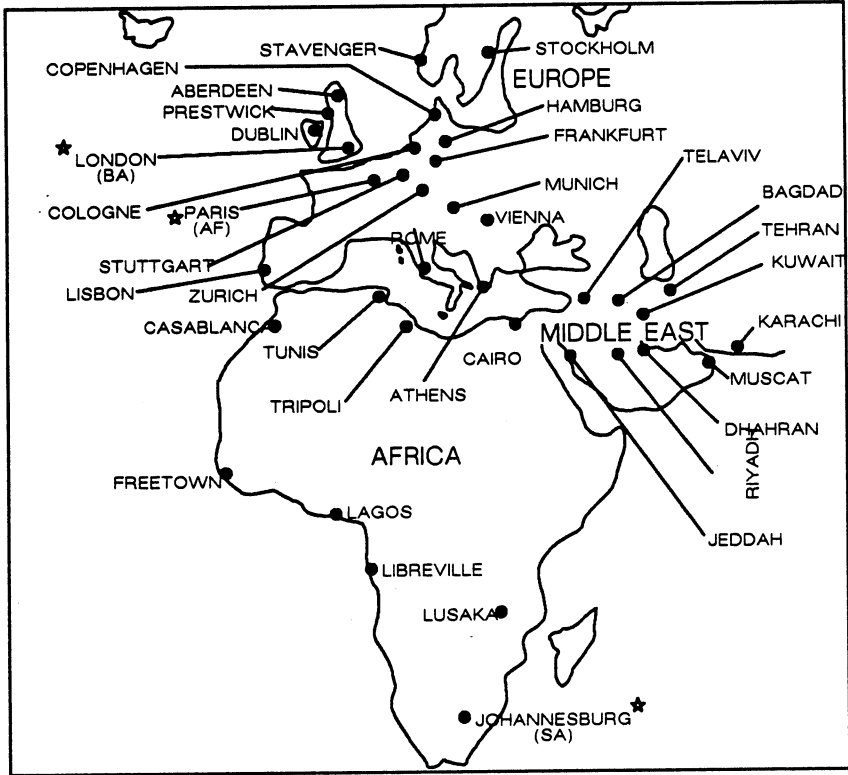

**WORLDWIDE DIRECTORY OF AIRCRAFT RECOVERY  
EQUIPMENT - EUROPE, MIDDLE EAST & AFRICA**

**5-20-03**

PAGE 6

OCT 10/90

**Boeing Canada**  
de Havilland Division  
**DASH 8 AIRCRAFT RECOVERY**

LOCATION	CONTROLLING AGENCY	AIRBAGS			RECOVERY JACKS			LIFTING SLINGS		
		QTY	DESCRIP/ CAP.	MFR	QTY	DESCRIP/ CAP.	MFR	QTY	DESCRIP/ CAP.	MFR
LONDON, ENGLAND	*BRITISH AIRWAYS HEATHROW AIRPORT	12	25M TONS 11 ELEMENT	RFD	2	85 TON LOW PROFILE-- RECOV. 30-122 IN LIFT	SKY -HI	2	2BA-10053 ADJUSTABLE UP TO B747 30/35 TON	BA
		5	25M TONS 15 ELEMENT	RFD	1	50 TON LOW PROFILE-- RECOV. 14-56 IN LIFT	SKY -HI			
		2	40M TONS 15 ELEMENT	RFD						
LONDON, GATWICK	BRITISH AIRPORT AUTHORITY	6	25M TONS 11 ELEMENT	RFD						
		5	25M TONS 15 ELEMENT	RFD						
		2	40M TONS 15 ELEMENT	RFD						
PRESTWICK, SCOTLAND	BRITISH AIRPORT AUTHORITY	8	25M TONS 11 ELEMENT	RFD						
		5	25M TONS 15 ELEMENT	RFD						
		2	40M TONS 15 ELEMENT	RFD						
ABERDEEN, SCOTLAND	BRITISH AIRPORT AUTHORITY	6	25M TONS 11 ELEMENT	RFD						
		2	25M TONS 11 ELEMENT	RFD						

\*IATP POOL

WORLDWIDE DIRECTORY OF AIRCRAFT RECOVERY  
EQUIPMENT - EUROPE, MIDDLE EAST & AFRICA

**5-20-03**

PAGE 7

OCT 10/90

Boeing Canada  
de Havilland Division

DASH 8 AIRCRAFT RECOVERY

LOCATION	CONTROLLING AGENCY	AIRBAGS			RECOVERY JACKS			LIFTING SLINGS		
		QTY	DESCRIP/ CAP.	MFR	QTY	DESCRIP/ CAP.	MFR	QTY	DESCRIP/ CAP.	MFR
DUBLIN, IRELAND	AER RIANTA	6	25M TONS 11 ELEMENT 12M TONS	RFD	1	50 TON		---		
		3								
FRANKFURT, GERMANY	LUFTHANSA		---		2	100 TON RECOVERY	MALA -BAR MOD. 8294	---		
		6	25M TONS 15 ELEMENT	RFD	1			30 TON 15 TON B707 OR SMALLER	F.A. SCHELLEN -BERG	
COPENHAGEN DENMARK	FALCK CO.	2	29M TONS 305 CM	VEPRO		---		---		
		2	40M TONS 305 CM							
SHANNON IRELAND	EIRE AIRPORT AUTHORITY	10	10 TONS	RFD	1	50 TON		---		
		10	5M TONS	RFD	2	30 TON		---		
TUNIS, TUNISIA	TUNIS AIR	6	25 M TONS TYPE "D"	RFD	3	20 TON		---		
					1	16 TON 57-108 IN LIFT	S.A. PAYLAN			
					1	14.8 TON 57-108 IN LIFT	S.A. PAYLAN			
					6	29.5 TON 58-121 IN LIFT	S.A. PAYLAN			
					2	49.2 TON MAIN LDG. GEAR	S.A. PAYLAN			
					1	39.3 TON NOSE LDG. GEAR	HYDR0GER ATEBAU			

\*IATP POOL

WORLDWIDE DIRECTORY OF AIRCRAFT RECOVERY  
EQUIPMENT - EUROPE, MIDDLE EAST & AFRICA

5-20-03

PAGE 8

OCT 10/90

DASH 8 AIRCRAFT RECOVERY

LOCATION	CONTROLLING AGENCY	AIRBAGS			RECOVERY JACKS			LIFTING SLINGS		
		QTY	DESCRIP/ CAP.	MFR	QTY	DESCRIP/ CAP.	MFR	QTY	DESCRIP/ CAP.	MFR
CASABLANCA, MOROCCO AEROPORT DE CASA- NOUVASSER	ROYAL AIR MAROC	4	5M TONS TYPE "50" 183 CM X 213 CM X 183 CM HIGH	AERAZUR FRANCE						
		6	12M TONS TYPE "120"	AERAZUR FRANCE						
KARACHI, PAKISTAN	PAKISTAN INTL AIRLINES	2	40M TONS	RFD						
		5	25M TONS HIGH LIFT							
		2	25M TONS LOW LIFT							
KUWAIT	KUWAIT AIRWAYS CORP.	6	25 M TONS TYPE 'D'	RFD	1	100 TON	HYDROLITE MOD. 6100			
TEHRAN, IRAN	IRAN AIR	6	25M TONS 13 ELEMENT	RFD						
HAMBURG, GERMANY	CIVIL AIRPORT AUTHORITY	6	12 TON 6 FT X 6 FT					2	25 TON 16" WIDE X 49 FT LONG	
		2	29M TONS 305 CM	VEPRO						
JOHANNES- BURG, SO. AFRICA JAN SMUTS AIRPORT	*SOUTH AFRICAN AIRWAYS	6	25M TONS 13 ELEMENT	RFD	2	100 TON 30-140 IN LIFT JACKS	SYNCR- LITE CORP. GODFREY		COMPONENT SUPPORT SLINGS UP TO 11,000 LBS. (5,170 KGS)	
		2	40M TONS TYPE 'F' 20 ELEMENT	RFD						

\*IATP POOL

**Boeing Canada**  
de Havilland Division  
**DASH 8 AIRCRAFT RECOVERY**

LOCATION	CONTROLLING AGENCY	AIRBAGS			RECOVERY JACKS			LIFTING SLINGS		
		QTY	DESCRIP/ CAP.	MFR	QTY	DESCRIP/ CAP.	MFR	QTY	DESCRIP/ CAP.	MFR
BAGHDAD IRAQ	BAGHDAD CIVIL AIR AUTHORITY/ AIRPORT AND IRAQI AIRWAYS	6	25M TONS 11 ELEMENT	RFD		50 TON WING/BODY 25 TON WING/BODY 15 TON WING/BODY 100 TON WING/BODY 60 TON WING/BODY 30 TON WING/BODY 25 TON WING/BODY 60 TON AXLE	RE- GENT RE- GENT RE- GENT MALA -BAR MALA -BAR MALA -BAR MALA -BAR MALA -BAR			
		3	12 TON TYPE "F2" 6 FT LIFT							
STAVENGER, NORWAY	NORWEGIAN AIR FORCE HANGAR NO. 3				1	JACKING BEAM B2510-737 10 TON	COLUMBUS COLUMBUS COLUMBUS RE- GENT			
	BRAATHENS S.A.F.E.				2					
				1	45 TON RHINO NO. 5923					
ATHENS, GREECE	GREEK CAA	15	12 TON		8 10	15 TON 25 TON			1	13 TON
	PRIVATE FIRM								1	13 TON
	FIRE DEPT.								2	25 TON
									2	30 TON
									1	25 TON

\*IATP POOL

WORLDWIDE DIRECTORY OF AIRCRAFT RECOVERY  
EQUIPMENT - EUROPE, MIDDLE EAST & AFRICA

**5-20-03**

PAGE 10

OCT 10/90

**Boeing Canada**  
de Havilland Division  
**DASH 8 AIRCRAFT RECOVERY**

LOCATION	CONTROLLING AGENCY	AIRBAGS			RECOVERY JACKS			LIFTING SLINGS		
		QTY	DESCRIP/ CAP.	MFR	QTY	DESCRIP/ CAP.	MFR	QTY	DESCRIP/ CAP.	MFR
TRIPOLI, LIBYA	LIBYAN ARAB AIRLINES	2	40M TONS TYPE "F" 15 ELEMENT	RFD	2	100 TON RAMJACKS				
		5	25M TONS TYPE "G" 15 ELEMENT	RFD						
		2	25M TONS TYPE "H" 11 ELEMENT	RFD						
LIBREVILLE, GABON	AIR GABON				3	15 TON 45-125 IN LIFT	KONI MOD. 3225			
					2	5 TON 40-90 IN LIFT	HYDROG- ERATEBAU MOD. 1881			
					2	30 TON 60-110 IN LIFT	HENGSTER MOD. FH-30			
					2	10 TON 90-150 IN LIFT	SEFAH MOD. TRDIO-T BENDIX B-28			
					3	20 TON 50-100 IN LIFT				

\*IATP POOL

WORLDWIDE DIRECTORY OF AIRCRAFT RECOVERY  
EQUIPMENT - EUROPE, MIDDLE EAST & AFRICA

**5-20-03**

PAGE 11

OCT 10/90

**Boeing Canada**  
de Havilland Division  
**DASH 8 AIRCRAFT RECOVERY**

LOCATION	CONTROLLING AGENCY	AIRBAGS			RECOVERY JACKS			LIFTING SLINGS		
		QTY	DESCRIP/ CAP.	MFR	QTY	DESCRIP/ CAP.	MFR	QTY	DESCRIP/ CAP.	MFR
LIBREVILLE, GABON (CONT'D)	AIR GABON				2	25 TON 60-106 IN LIFT	BENDIX 725A			
					1	10 TON 90-125 IN LIFT	BENDIX 713A		---	
					1	10 TON 53-88 IN LIFT	BENDIX 714A			
LAGOS, NIGERIA	NIGERIA DEPT. OF CIVIL AVIATION	10	25M TONS 11 ELEMENT	RFD		1 SET UBM HOVERSYSTEM MARK III				
FREETOWN, SIERRA LEONE	SIERRA LEONE AIRPORT AUTHORITY	6	25M TONS 11 ELEMENT	RFD						
LISBON, PORTUGAL	ANA EP AERO PORTOSE NAVEGACAO AEREA EP (AIRBAGS)	7	12 TON 8"-20" LIFT	ZO- DIAC PERE -IRA E BRITO		100 TON 97-193 IN LIFT	REGENT MOD. 8356R			
		10	25 TON 20"-147" LIFT		1	50 TON 44 IN LIFT	REGENT MOD. 2955			
	TA PORTUGUESES AIRLINES (JACKS & SLINGS)				1	60 TON 221-321 IN LIFT	REGENT MOD. 8357R			
					7	15 TON	REGENT MOD. 29580			

\*IATP POOL

WORLDWIDE DIRECTORY OF AIRCRAFT RECOVERY  
EQUIPMENT - EUROPE, MIDDLE EAST & AFRICA

**5-20-03**

PAGE 12

OCT 10/90



**Boeing Canada**  
de Havilland Division  
**DASH 8 AIRCRAFT RECOVERY**

LOCATION	CONTROLLING AGENCY	AIRBAGS			RECOVERY JACKS			LIFTING SLINGS		
		QTY	DESCRIP/ CAP.	MFR	QTY	DESCRIP/ CAP.	MFR	QTY	DESCRIP/ CAP.	MFR
LISBON, PORTUGAL (CONT'D)	TA PORTUGUESES AIRLINES (JACKS & SLINGS) (CONT'D)		---		1	30 TON 82-172 IN LIFT	REGENT MOD. 8357R			
			---		2	25 TON 40 IN LIFT	REGENT MOD. 986			
			---		2	15 TON 148-249 IN LIFT	REGENT MOD. 8359			
			---		2	15 TON 183-297 IN LIFT	REGENT MOD. 8330			
ROME, ITALY	FIUMICINO AIRPORT S.A.R.	2	40M TONS TYPE "F" 15 ELEMENT	RFD	4	100 TON RECOVERY				
		5	25M TONS TYPE "G" 15 ELEMENT	RFD						
		2	25M TONS TYPE "H" 11 ELEMENT	RFD						
TEL AVIV, ISRAEL	BEN GURION INTL AIRPORT	4	12M TONS	RFD MOD. A3420	10	50 TON TRIPOD 60-132 IN LIFT	DARU	1	SLING 25 TON OHME 68B00002 10 TON	P.F. INDUS- TRIES LIFT ALL CO. EM2806
					2	50 TON 60-132 IN LIFT	HENGSTER	2		

\*IATP POOL

WORLDWIDE DIRECTORY OF AIRCRAFT RECOVERY  
EQUIPMENT - EUROPE, MIDDLE EAST & AFRICA

**5-20-03**

PAGE 13

OCT 10/90

**Boeing Canada**  
de Havilland Division  
**DASH 8 AIRCRAFT RECOVERY**

LOCATION	CONTROLLING AGENCY	AIRBAGS			RECOVERY JACKS			LIFTING SLINGS		
		QTY	DESCRIP/ CAP.	MFR	QTY	DESCRIP/ CAP.	MFR	QTY	DESCRIP/ CAP.	MFR
ZURICH, SWITZERLAND	SWISSAIR AIRLINES	7 2	25M TONS 40M TONS	RFD RFD	3	100 TON RECOVERY	REAGENT	2	35 TON	
STOCKHOLM, SWEDEN	CIVIL AIRPORT AUTHORITY	2	29M TONS 305 CM 29M TONS 245 CM	VE- PRO						
STUTTGART, GERMANY	STUTTGART AIRPORT AUTHORITY	2	25M TONS 11 ELEMENT	RFD		-----			-----	
VIENNA, AUSTRIA	VIENNA AIRPORT AUTHORITY	2	25M TONS 11 ELEMENT	RFD		-----			-----	
DHAHRAN, SAUDI ARABIA	SAUDI ARABIA AIRPORT AUTHORITY	6	25M TONS 11 ELEMENT	RFD		-----			-----	
RIYADH, SAUDI ARABIA	SAUDI ARABIA AIRPORT AUTHORITY	6	25M TONS 11 ELEMENT	RFD		-----			-----	
JEDDAH, SAUDI ARABIA	SAUDI ARABIA AIRPORT AUTHORITY	6	25M TONS 11 ELEMENT	RFD		-----			-----	

\*IATP POOL

WORLDWIDE DIRECTORY OF AIRCRAFT RECOVERY  
EQUIPMENT - EUROPE, MIDDLE EAST & AFRICA

**5-20-03**

PAGE 14

OCT 10/90

**Boeing Canada**  
de Havilland Division  
**DASH 8 AIRCRAFT RECOVERY**

LOCATION	CONTROLLING AGENCY	AIRBAGS			RECOVERY JACKS			LIFTING SLINGS		
		QTY	DESCRIP/ CAP.	MFR	QTY	DESCRIP/ CAP.	MFR	QTY	DESCRIP/ CAP.	MFR
PARIS, FRANCE ORLY AIRPORT	* AIR FRANCE	8	25M TONS 15 ELEMENT	RFD						
		2	40M TONS 15 ELEMENT	VE- PRO						
		2	40M TONS 305 CM							
LUSAKA, ZAMBIA	ZAMBIA, AIRPORT AUTHORITY	6	25M TONS 15 ELEMENT	RFD						
MUSCAT	MUSCAT DEFENSE DEPT.	4	25M TONS 11 ELEMENT	RFD						
MUNICH GERMANY	CIVIL AIRPORT AUTHORITY	2	29M TONS 305 CM	VE- PRO						
COLOGNE GERMANY	CIVIL AIRPORT AUTHORITY	1	12M TONS 162 CM	VE- PRO						
		1	29M TONS 305 CM							

\*IATP POOL

WORLDWIDE DIRECTORY OF AIRCRAFT RECOVERY  
EQUIPMENT - EUROPE, MIDDLE EAST & AFRICA

**5-20-03**

PAGE 15

OCT 10/90

**Boeing Canada**  
de Havilland Division  
**DASH 8 AIRCRAFT RECOVERY**

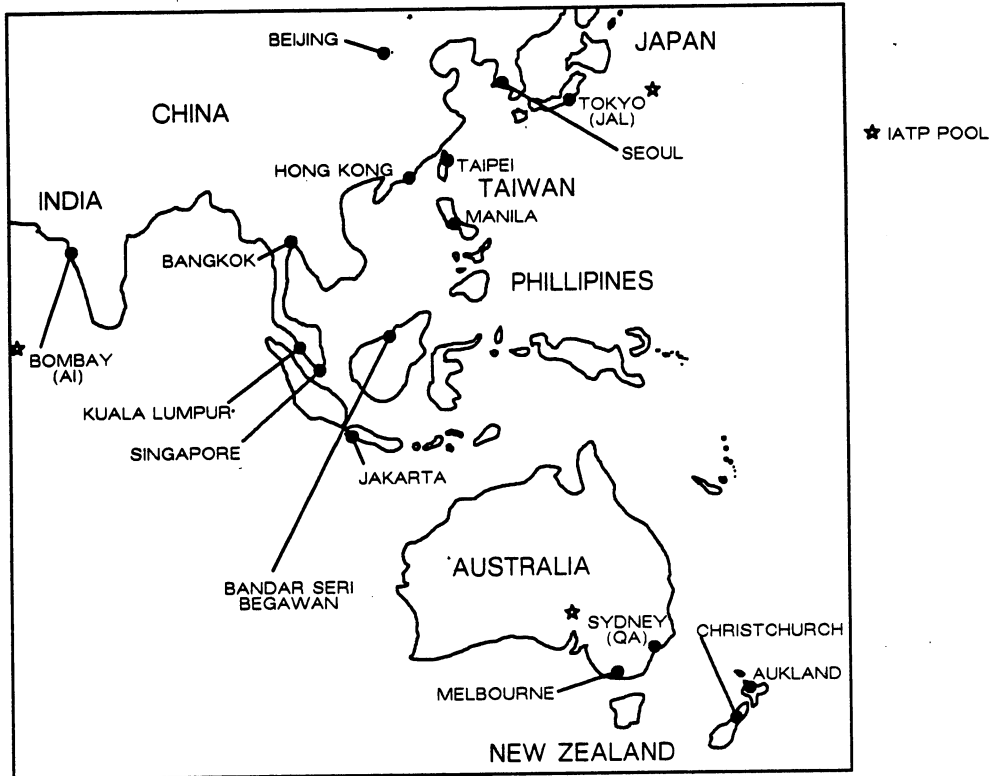

**WORLDWIDE DIRECTORY OF AIRCRAFT RECOVERY  
EQUIPMENT - AUSTRALIA & FAR EAST**

**5-20-03**

PAGE 16

OCT 10/90

**Boeing Canada**  
de Havilland Division  
**DASH 8 AIRCRAFT RECOVERY**

LOCATION	CONTROLLING AGENCY	AIRBAGS			RECOVERY JACKS			LIFTING SLINGS		
		QTY	DESCRIP/ CAP.	MFR	QTY	DESCRIP/ CAP.	MFR	QTY	DESCRIP/ CAP.	MFR
TOKYO, JAPAN NARITA	*JAPAN AIRLINES	6	25M TONS 11 ELEMENT 29M TONS 305 CM 29M TONS 245 CM	RFD  VE- PRO	2	80 TON RECOV. 30 TO 118 IN LIFT	MALA-BAR MOD. 8207	2	OHME65B000 02 45 TON	JAL
		6	25M TONS TYPE "D" 45M TONS TYPE "F" 10 TON 3 ELEMENT 3057-200	RFD RFD GOOD YEAR	2	80 TON LOW PROFILE MOD. 8207C	MALA-BAR	1 1 1 1 1	BODY QBA 10053 FIN REMOV. OHME65B001 86 WING GEAR TRUNION CLAMPS ME65B00161 PWR PLANT FIN FOLD.	BRIT AIRWY BOEING  BOEING  BOEING
		4 2 11 2	25M TONS 231 CM 25M TONS 297 CM 12M TONS 228 CM 40M TONS	RFD RFD RFD RFD	2	LOW PRO- FILE STRUT- MODIFIED HAECO CO 80 TON LOW PROFILE		2 1	40 FT X 2 FT STEEL 3OHME65B00 002 45 TON - 747	P.F. INDUS -TRIES
KUALA LUMPUR, MALAYSIA	MALAYSIAN AIRLINE	6	25 M TONS 231 CM	RFD		-----		-----		

\*IATP POOL

WORLDWIDE DIRECTORY OF AIRCRAFT RECOVERY  
EQUIPMENT - AUSTRALIA & FAR EAST

**5-20-03**

PAGE 17

OCT 10/90

**Boeing Canada**  
de Havilland Division  
**DASH 8 AIRCRAFT RECOVERY**

LOCATION	CONTROLLING AGENCY	AIRBAGS			RECOVERY JACKS			LIFTING SLINGS		
		QTY	DESCRIP/ CAP.	MFR	QTY	DESCRIP/ CAP.	MFR	QTY	DESCRIP/ CAP.	MFR
TPE TAIPEI, TAIWAN	CCAA CHINESE CIVIL AERONAUTIC AIRPORT ADMIN.	3	40 M TONS	RFD	1	AXLE JACKS 10 TON	REGENT			
		7	12M TONS		1	11-31 IN 17 TON				
DJAKARTA, INDONESIA	PE PERTAMINA (PELITA AIR SERVICE)				1	9-35 IN 12 TON				
					1	8-23 IN 50 TON				
					2	10-22 IN 20 TON				
					3	10-36 IN TRIPOD JACK				
					5	898R 40 TON 60-120 IN				
					3	AFT BODY/ OUTBD WING 12 TON	MALA -BAR 713A			
					2	120-174 IN FWD BODY 20 TON	MALA -BAR 718A			
					2	72-100 IN INBD WING 60 TON	MALA -BAR 767			
					1	66-122 IN EMERG. JACK BEAM MOD. 60L 4.5	MALA -BAR			
					2	GEN PUR- PORSE 20 TON 52071	SKY- HI			

\*IATP POOL

WORLDWIDE DIRECTORY OF AIRCRAFT RECOVERY  
EQUIPMENT - AUSTRALIA & FAR EAST

**5-20-03**

PAGE 18

OCT 10/90

**Boeing Canada**  
de Havilland Division  
**DASH 8 AIRCRAFT RECOVERY**

LOCATION	CONTROLLING AGENCY	AIRBAGS			RECOVERY JACKS			LIFTING SLINGS		
		QTY	DESCRIP/ CAP.	MFR	QTY	DESCRIP/ CAP.	MFR	QTY	DESCRIP/ CAP.	MFR
BANGKOK, THAILAND	DIR. OF CIVIL AVIATION, R.T.A.F.	2	40M TONS 15 ELEMENT	RFD						
		2	25M TONS 11 ELEMENT	RFD						
	THAI INTL. AIRLINES	2	40M TONS 305 CM	VE- PRO		MAINT. JACKS 80 TONS, 20 TONS, 15 TONS, 46.5 TONS, 50 TONS, 100 TONS				
BOMBAY, INDIA	*AIR INDIA	12	25M TONS 11 ELEMENT MODEL 32024-11	RFD	2	100 TON RECOV. 28-140 IN LIFT	REGENT	1	SLING ASSY OHME65B00 002	BOEING
					1	60 TON RECOV. 88-309 IN LIFT	REGENT			
SEOUL, KOREA	KOREAN AIRLINES	2	40 M TONS TYPE "F"	RFD	2	100T ON RECOV. 28-140 IN LIFT	REGENT	2	SLING ASSY 3 OHME65B00 002	
		5	25M TONS TYPE "G"		1	25 TON NOSE JACK 87-142 IN				
					2	100 TON MAIN WING JACK				
		2	25M TONS TYPE "H"		1	100-211 IN 50 TON TAIL JACK 233-302 IN				

\*IATP POOL

WORLDWIDE DIRECTORY OF AIRCRAFT RECOVERY  
EQUIPMENT - AUSTRALIA & FAR EAST

**5-20-03**

PAGE 19

OCT 10/90

**Boeing Canada**  
de Havilland Division  
**DASH 8 AIRCRAFT RECOVERY**

LOCATION	CONTROLLING AGENCY	AIRBAGS			RECOVERY JACKS			LIFTING SLINGS		
		QTY	DESCRIP/ CAP.	MFR	QTY	DESCRIP/ CAP.	MFR	QTY	DESCRIP/ CAP.	MFR
SEOUL, KOREA (CONT'D)	KOREAN AIRLINES			RFD	3	50 TON AXLE JACK	REGENT	2	SLING ASSY 3	
					1	15 TON NOSE JACK			OHME65B00 002	
					2	60-110 IN 50 TON WING JACK				
					2	60-110 IN 15 TON OUTBD WING JACK				
					1	124-172 IN 15 TON TAIL JACK				
SINGAPORE	SINGAPORE AIRLINES	2	25 M TONS 15 ELEMENT TYPE "G"	RFD						
		4	25M TONS 11 ELEMENT TYPE "D"	RFD						
NAHA OKINAWA	SOUTHWEST AIRLINES (NU)				2	(737) 30 TON ALLIGATOR				
					1	7-19 IN 10 TON FWD BODY				
					1	54-96 IN 20 TON AFT BODY				
					1	88-143 IN 30 TON WING				

\*IATP POOL



**Boeing Canada**  
de Havilland Division  
**DASH 8 AIRCRAFT RECOVERY**

LOCATION	CONTROLLING AGENCY	AIRBAGS			RECOVERY JACKS			LIFTING SLINGS		
		QTY	DESCRIP/ CAP.	MFR	QTY	DESCRIP/ CAP.	MFR	QTY	DESCRIP/ CAP.	MFR
MANILA, PHILLIPINES	CIVIL AVIATION ADMIN.	4	25M TONS 15 ELEMENT	RFD	1 SET - RFD DRAGON JACK SYSTEM.					
		2	25M TONS 11 ELEMENT							
MELBOURNE AUSTRALIA	*QANTAS AIRWAYS	6	25M TONS 11 ELEMENT	RFD						
		3	40M TONS 15 ELEMENT							
BANDAR SERI BEGAWAN, BRUNEI	DEPT. OF DEFENSE	5	25M TONS 15 ELEMENT	RFD						
		2	25M TONS 11 ELEMENT							
BEIJING CHINA	CIVIL AVIATION AUTHORITY	2	40M TONS 305 CM	VE- PRO						
		5	29M TONS 305 CM							
		2	29M TONS 245 CM							
		2	12M TONS 162 CM							

\*IATP POOL

WORLDWIDE DIRECTORY OF AIRCRAFT RECOVERY  
EQUIPMENT - AUSTRALIA & FAR EAST

**5-20-03**

PAGE 21

OCT 10/90

**Boeing Canada**  
de Havilland Division  
**DASH 8 AIRCRAFT RECOVERY**

**THIS PAGE INTENTIONALLY LEFT BLANK**

**5-20-03**

PAGE 22

OCT 10/90

**Boeing Canada**  
de Havilland Division

**DASH 8 AIRCRAFT RECOVERY**

**LIST OF EFFECTIVE PAGES: CHAPTER 6: PREVIOUS AIRCRAFT RECOVERY EXPERIENCE**

<b>Reference</b>	<b>Page</b>	<b>Date</b>	<b>Reference</b>	<b>Page</b>	<b>Date</b>
Contents	1	Oct 10/90			
	2	Blank			
6-00-00	1	Oct 10/90			
	2	Blank			
6-10-00	1	Oct 10/90			
	2	Oct 10/90			

The asterisk (\*) indicates pages revised, added or deleted by current revision.

**6 – EFFECTIVE PAGES**

**Boeing Canada**  
de Havilland Division  
**DASH 8 AIRCRAFT RECOVERY**

**THIS PAGE INTENTIONALLY LEFT BLANK**

**6 – EFFECTIVE PAGES**

PAGE 2

OCT 10/90

**DASH 8 AIRCRAFT RECOVERY**

**CHAPTER 6 - PREVIOUS AIRCRAFT RECOVERY EXPERIENCE**

**TABLE OF CONTENTS**

<b>Subject</b>	<b>Chapter Section Subject</b>	<b>Page</b>
<b>PREVIOUS AIRCRAFT RECOVERY</b>	<b>6-00-00</b>	
General		1
<b>AIRCRAFT INCIDENTS</b>	<b>6-10-00</b>	
Right Hand Main Gear Collapsed during Take-off Roll		1
Right Main Landing Gear Retracted as Aircraft Taxied from Ramp		1
Aircraft Executed Very Heavy Landing on Runway Threshold		
Aircraft Landed with Retracted Nose Landing Gear		2

**6-CONTENTS**

**Boeing Canada**  
de Havilland Division  
**DASH 8 AIRCRAFT RECOVERY**

**THIS PAGE INTENTIONALLY LEFT BLANK**

**6-CONTENTS**

**PAGE 2**

**OCT 10/90**

## **DASH 8 AIRCRAFT RECOVERY**

### **PREVIOUS AIRCRAFT RECOVERY EXPERIENCE**

#### **1. General**

Previous recovery experiences with similar type aircraft are provided in this chapter. Each incident is unique, thus requiring specific equipment or a combination of equipment. In all cases, defueling the aircraft will need to be accomplished before lifting or towing operations, for safety reasons.

Recovery techniques of standard body aircraft are recorded in other aircraft recovery manuals and can be applicable after some modification to the Dash-8 aircraft.

**6-00-00**

PAGE 1

OCT 10/90

**Boeing Canada**  
de Havilland Division  
**DASH 8 AIRCRAFT RECOVERY**

**THIS PAGE INTENTIONALLY LEFT BLANK**

**6-00-00**

**PAGE 2**

**OCT 10/90**



## **DASH 8 AIRCRAFT RECOVERY**

### **AIRCRAFT INCIDENTS**

#### **1. Right Hand Main Gear Retracted during Take-off Roll**

As aircraft was rolling down runway at start of take-off the pilot noticed a red light illuminate on the landing gear panel, simultaneously aircraft settled right wing down and belly struck the runway. Right hand gear retracted and aircraft pivoted about the other two gears, the right outboard wheel then jammed against the aft wheel door and started skidding on the runway swinging the aircraft further to the right, right wing dropped and made ground contact at right wing tip and right propeller. The aircraft slid to a stand still at an approximate 40 degree angle to the right of the runway heading.

Damage to wing was minor distortion of wing tip.

There were no injuries and also no fire.

Removal of aircraft started the following day by use of airbags after the damaged propeller had been removed.

Further damage to the aircraft occurred during recovery, the failure of an airbag supporting the right wing let the wing fall on the jack and onto the bag support platform. Damage occurred to the lower surface of the wing box between the nacelle and fuselage inboard leading edge and the outer end of flap.

#### **2. Right Main Landing Gear Retracted as Aircraft Taxied from Ramp**

Aircraft was in the process of straightening from a right hand turn, the nose wheel crossed over a drainage grate that was built into the tarmac, shortly after the nose had crossed over the grate the right main landing gear inadvertently retracted, causing the right hand propeller (number two) and right wing tip to strike the surface of the ramp. Aircraft settled on the right wing tip, the right undercarriage doors and nacelle, a single blade from number two propeller and the rear fuselage.

Passengers and crew were evacuated from the aircraft without any injuries, there was no fire.

The aircraft was lifted the following morning utilizing aircraft jacks and a wide-body aircraft cargo lift.

Landing gear lowered by means of emergency hydraulic system and ground lock pin installed, aircraft was then moved approximately one quarter mile from ramp area and re-jacked for inspections.

#### **3. Aircraft Executed Very Heavy Landing on Runway Threshold, Left Main Landing Gear Pivot Pin Sheard.**

During landing the left main landing gear collapsed, the aircraft slid off the runway coming to rest on the grass between parallel runways. The left propeller (number one) contacted the surface of the runway and one blade was shed, damaged areas of aircraft include belly, nacelle, fuselage side panels, number one engine and propeller.

**6-10-00**

## **DASH 8 AIRCRAFT RECOVERY**

Preliminary reports indicated that the yoke pivot pin for the landing gear shock strut sheared on touch-down because of heavy landing on left main gear.

Shortly following touch-down crew became aware left main landing gear had begun to collapse, the aircraft continued down the runway veering slightly to the left rotating 90 degrees into a southerly direction.

There were no injuries and crew exited by the airstair door, there was also no fire.

Runway was closed for approximately four hours, further damage incurred to aircraft during recovery. A sling was placed around the left wing outboard of the nacelle and a crane was used to raise the aircraft, both leading edge D nose and trailing edge flap shroud sustained damage.

#### **4. Aircraft Landed with Retracted Nose Landing Gear**

Aircraft landed with nose gear retracted, cockpit indication reported all gears were down and locked, the absence of the nose gear only became evident after touch-down, the nose was held clear of ground as low as possible to minimize structural damage.

As the nose was lowered while at a speed of approximately 40 to 45 knots (74.13 to 83.4 KM) the pilot heard scraping noises emanating from beneath the flight compartment and instructed the first officer to hold aircraft's nose clear of the runway as long as possible. The aircraft slowed with the under surface of its nose gear doors in contact with the runway surface and slid in a straight line to a stop.

Passengers and crew evacuated the aircraft by way of the main airstair door which still cleared the ground, there were no injuries and also no fire.

The aircraft was recovered from the runway using a crane and sling. The nose was lifted and the nose landing gear was extended using the alternate extension system to lock the gear down (ground lock pins installed in all landing gears) prior to its re-location to the maintenance facility.

Impact forces were concurrent with those felt during a normal landing and as such, caused no major airframe, system or structural damage.

**6-10-00**

PAGE 2

OCT 10/90